

SENSALARM FLEX

Universal Gas Detection System



User Manual

Document No. 360-0257-01 (Rev D)

SENSIDYNE[®]
Industrial Health & Safety Instrumentation

How to Use This Manual

This manual is a basic guide for using the SensAlarm Flex Universal Gas Monitoring System. It contains information on SensAlarm Flex components, sensor types, Graphical User Interface, and user interactions. It also details elements such as how to mount and wire the Universal Gas Monitoring System, setup, zero, and span calibration. In addition, it covers commonly used operations regarding alarms, relays, and Test-On-Demand.

Important notes, cautions, and warnings are highlighted from the other text as follows:

NOTE: Relevant Text

WARNING: Relevant Text

CAUTION: Relevant Text and Related Symbol

Basic Menu Controls Guide

The SensAlarm Flex Graphical User Interface is navigated by a non-intrusive magnetic interface. Users select actions by moving a magnet over the six (6) different front panel functions, which are Escape (ESC), Up, Down, Left, Right, and Enter.

Selecting Enter from the Normal Operation Display enters the SensAlarm Flex menu system. Within the main menu, the user will arrow to select System or Sensor menu options. Enter is then used to further drill down to the desired submenu options, and to accept changes made. Escape (ESC) is similar in use to an ESC key on a computer keyboard, which exits the selection without changes, and reverts the user to the previous menu option. To return to the Normal Operational Display, ESC is selected until the display is revealed.



NOTE:

This manual contains illustrations of display screen menu options generally used in the setup and operation of the SensAlarm Flex Universal Gas Monitoring System. The Gas Monitoring System may also display a variety of additional warning or cautionary screens. These additional display screens are instructive and intuitive in nature. The user should read each displayed screen and perform the recommended actions as required.

IMPORTANT: Factory Default Settings

Each Universal Gas Monitor is shipped from the factory with default settings. These include default settings for alarms, faults, strobes, horn, and relays. The default settings can be found in Section **X**. Please note that boxes filled with an "X" indicate a default setting for that particular alarm, fault, strobe, horn, or relay. Additional blank copies of the Configuration Reference form can be found in Section **X**. These blank forms are intended for use by the user to document user-defined changes from the factory default settings.

Table of Contents

How to Use This Manual	3
Table of Contents	4
Packing List and Notices	7
1. INTRODUCTION	10
1.1. Product Versions	10
1.2. Standard Features	12
1.2.1. Universal Sensor Capability	12
1.2.2. Large Display for Ease of Operation	12
1.2.3. Non-Intrusive Operation	12
1.2.4. Transportable Calibration	12
1.2.5. Predictive Sensor Failure	12
1.2.6. AC & External DC Power Compatibility.....	12
1.2.7. Communication Protocols	12
1.2.8. Relay Outputs.....	13
1.3. Factory Installed Options	13
1.3.1. Second Sensor Interface.....	13
1.3.2. Remote Sensors.....	13
1.3.3. Test-On-Demand™ Gas Generator	13
1.3.4. Stack Strobe Lights	13
1.3.5. Internal Battery Backup	13
1.3.6. Additional Relay Outputs.....	14
1.4. SensAlarm Flex Components.....	14
1.4.1. Sensor Interface Assembly	14
1.4.2. Plus Series Sensor	14
1.4.3. Test-on-Demand.....	14
1.4.4. Sensor Holder.....	14
1.4.5. Rainshield & Moisture Barrier.....	14
1.4.6. Calibration Plug	14
1.4.7. Relays.....	15
1.4.8. Modbus.....	16
1.4.9. 4 to 20 mA Output	17
1.4.10. Battery Backup.....	18
1.4.11. Horn and Silence Pushbutton	19
1.4.12. Front Panel LED Strobe.....	20
1.4.13. Stack Light (General Purpose Only)	20

1.4.14.	SensAlarm Flex Components (Summary)	21
1.4.15.	Display (Main Screen)	22
1.4.16.	Sensor Types.....	22
2.	INSTALLATION	25
2.1.	Location	25
2.2.	Code Compliance	25
2.3.	Gas Monitor Installation	25
2.3.1.	AC Power	27
2.3.2.	DC Power	27
2.3.3.	4 to 20 mA	29
2.3.4.	Relays.....	29
2.3.5.	Modbus.....	30
2.3.6.	Field Wire Terminating Locations (Summary).....	32
3.	STARTUP	33
3.1.	Power On.....	33
3.2.	Sensor Installation	34
4.	OPERATING FUNCTIONS	35
4.1.	Calibration.....	35
4.2.	Zero Calibration	37
4.3.	Span Calibration	39
4.3.1.	Sensor Adjustment	39
4.3.2.	Set Cal Gas Conc. (Concentration).....	40
4.3.3.	Calibrate	40
4.4.	Test-on-Demand™ (ToD).....	41
5.	ALARMS, FAULTS AND RELAYS.....	44
5.1.	Alarms.....	44
5.2.	Faults	46
5.3.	Relays.....	49
5.4.	Strobes	52
6.	CONFIGURATION	54
6.1.	4 to 20mA Adjustment	54
6.2.	Communication Setup	56
6.2.6.	Modbus Register Types and Locations.....	59
6.3.	Menu Structure	62
6.3.1.	System Menu.....	62
6.3.2.	SYSTEM CONFIGURATION (Submenus).....	63
6.3.3.	CHANNEL CONFIGURATION (Sensor CH-1 & CH-2 Submenus)	70

7. APPENDIX A: SPECIFICATIONS	72
8. APPENDIX B: APPROVAL RATINGS	73
9. APPENDIX C RECOMMENDED REPLACEMENT PARTS.....	74
10. APPENDIX D: TROUBLESHOOTING GUIDE	75
11. APPENDIX E: RETURNED MATERIAL AUTHORIZATION (RMA)	77
12. APPENDIX F: CONFIGURATION REFERENCE	78
13. APPENDIX G: CERTIFICATION INSTALLATION DRAWING	82

Packing List and Notices

Each SensAlarm Flex Universal Gas Monitoring System includes:

- SensAlarm Flex Universal Gas Monitoring System User Manual (this document)
- The SensAlert Plus Sensor datasheet for selected sensors
- A reversible screwdriver with magnetic wand

(SensAlert Plus Sensors sold separately)

If you have any questions, need assistance, or are missing any of the above items, please contact your Sensidyne Manufacturer Representative, or contact Sensidyne Customer Support at 800-451-9444 or +1-727-530-3602.

PROPRIETARY NOTICE

This manual was prepared by Sensidyne, LP exclusively for owners of the SensAlarm Flex Universal Gas Monitoring System. The information within this manual is proprietary property of Sensidyne, LP and is to be used only to understand and operate the instrument. By receiving this document, the recipient agrees that neither this document, nor the information disclosed within, nor any part shall be reproduced or transferred, physically, electronically or in any form, or used or disclosed to others for manufacturing, or for any other purpose except as specifically authorized in writing by Sensidyne, LP.

COPYRIGHT NOTICE

© 2020, 2025 Sensidyne, LP, all rights reserved. Information contained in this document is protected by copyright. No part of this document may be photocopied, reproduced, or translated to another program or system without prior written authorization from Sensidyne, LP.

TRADEMARK NOTICE

Sensidyne, the Sensidyne logo, SensAlert, SensAlarm, SensAlarm Flex, SensAlert Plus logos, and Test-on-Demand (ToD) are registered trademarks of Sensidyne, LP. The trademarks and service marks of Sensidyne, LP are protected through use and registration in the United States of America.

SOFTWARE LICENSE

The software included with the SensAlarm Flex Universal Gas Monitoring System is the property of Sensidyne, LP and shall remain the property of Sensidyne, LP in perpetuity. The software is protected by U.S. and international copyright laws and is licensed for specific use with the SensAlarm Flex Universal Gas Monitoring System. Neither the user nor owner may reverse-engineer, disassemble, decompile, or make any attempt to discover the source code of the software. The software may not be translated, copied, merged or modified in any way. Neither the user nor owner may sublicense, rent, or lease any portion of the software. The right to use the software terminates automatically if any part of this license is violated.

DISCLAIMER

SENSIDYNE, LP ASSUMES NO RESPONSIBILITY WHATSOEVER, TO ANY PARTY WHOSOEVER, FOR ANY PROPERTY DAMAGE, PERSONAL INJURY, OR DEATH CAUSED BY OR RESULTING FROM, IN WHOLE, OR IN PART, THE IMPROPER USE, INSTALLATION, OR STORAGE OF THIS PRODUCT BY THE USER, PERSON, FIRM, ENTITY, CORPORATION OR PARTY NOT ADHERING TO THE INSTRUCTIONS AND WARNINGS OR NOT ADHERING TO ALL FEDERAL, STATE, AND LOCAL ENVIRONMENTAL AND OCCUPATIONAL HEALTH AND SAFETY LAWS AND REGULATIONS. THE SELLER SHALL NOT BE LIABLE FOR DIRECT, INDIRECT, CONSEQUENTIAL, INCIDENTAL OR OTHER DAMAGES RESULTING FROM THE SALE AND USE OF ANY GOODS AND SELLER'S LIABILITY HEREUNDER SHALL BE LIMITED TO REPAIR OR REPLACEMENT OF ANY GOODS

FOUND DEFECTIVE. THIS WARRANTY IS IN LIEU OF ALL OTHER WARRANTIES, EXPRESSED OR IMPLIED, INCLUDING BUT NOT LIMITED TO THE IMPLIED WARRANTIES OF MERCHANTABILITY AND FITNESS FOR USE OR FOR A PARTICULAR PURPOSE WHICH ARE EXPRESSLY DISCLAIMED.

WARNING: READ AND UNDERSTAND ALL WARNINGS AND INSTRUCTIONS BEFORE USE

Failure to read, understand, and comply with ALL accompanying literature, instructions, product labels, and warnings may result in property damage, severe personal injury, or death.

Product is tested and calibrated at the factory prior to shipment. However, this product must be calibrated prior to initial use and at regular intervals in accordance with this User Manual to ensure proper operation. Failure to calibrate and operate this product in accordance with this User Manual may result in the malfunction of the product.

Read and understand ALL applicable federal, state, and local environmental health and safety laws and regulations, including OSHA. Ensure complete compliance with ALL applicable laws, codes, and regulations before and during use of this product.

The owner, user, and installer must understand Hazardous Area Protection Concepts and Area Classifications associated with their application.

It is recommended that the user/installer read all procedures described in IEC 60079-29-2.

UNDER NO CIRCUMSTANCES should this product be used except by qualified or certified, trained, technically competent personnel, and not until the warnings, user manual, labels, and other literature accompanying this product have been read and understood.

ALWAYS wash your hands thoroughly after handling, calibrating, or servicing this product.

ALWAYS wear eye protection, such as safety goggles or a face shield, chemically resistant gloves, and chemically resistant clothing when handling chemicals, or calibration gas standard sources.

DO NOT get chemicals, gases, fumes, or vapors in your eyes or on your skin, as they may cause severe burns to skin and eyes. If chemicals, gases, fumes, or vapors get in your eyes or on your skin, wash the affected area thoroughly with water and seek immediately medical attention.

ALWAYS avoid contact with acids to your skin or eyes. Seek immediate medical attention for any contact with acids.

ALWAYS calibrate in a well-ventilated area. Adequate precautions should be taken to prevent the buildup of ANY calibration sources or vapors. Avoid breathing ANY calibration fumes or vapors as they may be hazardous to your health.

ALWAYS dispose of chemicals and calibration sources in compliance with ALL applicable safety laws, codes, regulations, and guidelines for proper disposal. Failure to do so may result in environmental damage, property damage, personal injury or death.

ALWAYS close ALL containers of chemicals used with this product after use.

ALWAYS ensure that any compressed calibration substance sources are empty prior to disposal.

ALWAYS use clean, dry, inert materials to contain and / or transfer substances used for calibration.

DO NOT remove, cover, or alter any label or tag on this product, its accessories, or related products.

DO NOT operate this product should it malfunction or require repair. Operation of a malfunctioning product or a product requiring repair may result in property damage, serious personal injury or death.

DO NOT attempt to repair or modify this product, except as specified in the User Manual. If repair is necessary, contact the Sensidyne Service Department to arrange for a Returned Material Authorization (RMA) (See APPENDIX E: RETURNED MATERIAL AUTHORIZATION for details).

ALWAYS operate this product in the manner intended. Failure to do so may result in property damage, serious personal injury or death.

Users should ALWAYS refer to MSDS and suppliers' instructions for proper safety instructions and handling for any chemicals used with this equipment.

Use ONLY genuine SENSIDYNE® replacement parts when performing any maintenance procedures described in this manual. Failure to do so may seriously impair the instrument performance. Repair or alteration of the product beyond the scope of these maintenance instructions, or by anyone other than an authorized SENSIDYNE® service technician, may cause the product to fail to function as designed, and persons who rely on this product for their safety could sustain severe personal injury or death.

The SensAlarm Flex Universal Gas Monitoring System is an ambient air monitoring device. Restricting the access of ambient air to the sensor may result in less than optimal monitoring performance. Prolonged exposure to excessively high concentrations of Toxic gas may cause the sensor to produce erroneous readings.

ALWAYS make use of genuine Sensidyne accessories, such as Rainshields, Splashguards, or Calibration Adapters to protect against variations caused by environmental conditions. Note that reactive Gases such as ETO, HF, HCN, NO₂, SO₂, HCl, ClO₂, or Cl₂ may require special considerations in use with certain Sensidyne accessories.

ALWAYS Perform tests only within the specified operating ranges.

Sudden changes in pressure may cause temporary fluctuations in the sensor reading.

Sensors should be hot-swapped only when the Normal Operation Mode screen is displayed.



CAUTION: Failure to read and understand the User Manual may result in property damage, severe personal injury or death.



CAUTION: Risk of electric shock if front cover is opened.

Important Calibration Considerations:

Verify the concentration of calibration gas standard before making calibration adjustments.

The concentration can be altered by:

- Deterioration of the gas concentration during storage due to shelf-life.
- Interaction of the calibration gas standard with incompatible materials used to contain and transfer the gas (tubing), absorption onto or permeation through certain plastics, polymers or elastomers.
- Interaction of the calibration gas standard with ambient contaminants, such as water.

If further translation is required, please contact the Sensidyne EU Authorized Representative (see Back Cover for contact information) or Sensidyne Customer Support at 800-451-9444 or +1-727-530-3602.

1. INTRODUCTION

This User Manual provides specific information concerning the installation, operation, calibration, and maintenance of the SensAlarm Flex Universal Gas Monitoring System.

The SensAlarm Flex is a “flexible” and highly configurable Universal Gas Monitoring System, which includes the standard incorporation of an integral front panel LED normal / alarm / fault strobe, audible 95dB horn, single sensor interface, four (4) relays, 4 to 20mA output, and Modbus RTU and TCP protocols. Options include a second sensor interface, one (1) to four (4) tier light stack, additional four (4) relays, battery backup, remote sensor kits, and many accessories for environmental protection and calibration accommodations. This product is perfectly suited for use in areas or facilities where control systems do not exist, and can facilitate multiple functional shutdowns or alarm notifications. Due to the “All-In-One” Universal Gas Monitoring System, the SensAlarm Flex substantially reduces the cost to facilitate these types of functional requirements. Where control systems do exist, the SensAlarm Flex facilitates these necessary functions, which allows the owner to avoid additional costs for annunciation and specific distributed intelligent control components, while providing the necessary interface with the facility control system. Some of the areas of interest may include, laboratory spaces, confined or secure areas, welding booths or personnel control centers.

SensAlarm Flex is capable of detecting the presence of potentially hazardous concentrations of Combustible vapors and gases, Toxic gases and Oxygen deficiency through the use of Plus Series Sensors, which are transportable sensors with onboard calibration records and historical exposure records. Sensidyne Manufacturer Representative or Sensidyne Customer Support can assist in identifying the appropriate sensor for customer applications.

1.1. Product Versions

The configuration of the SensAlarm Flex is part number specific. See the below configuration table for reference.



SensAlarm Flex

8 2 0 - 1 - - R

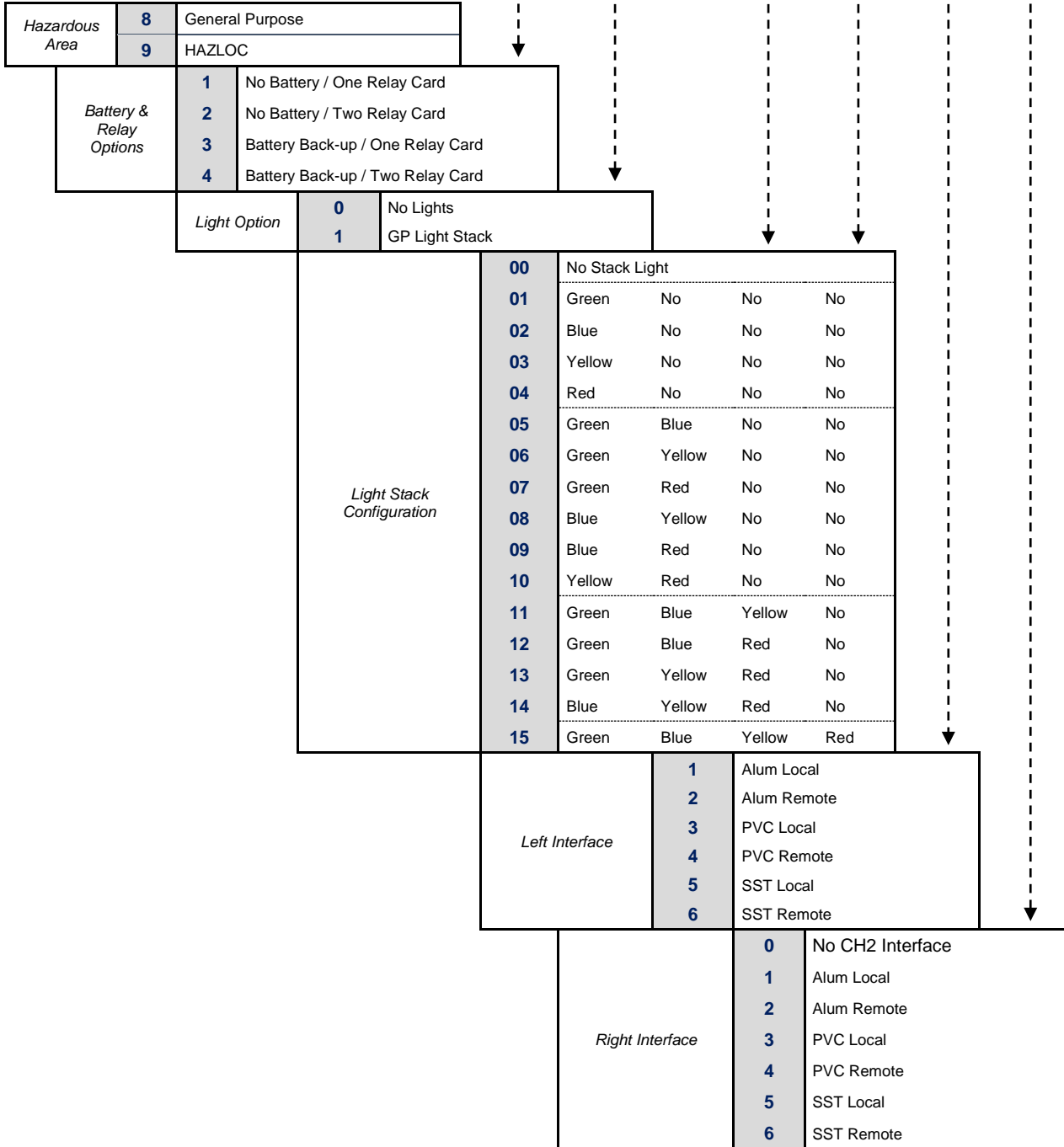

1.2. Standard Features

1.2.1. Universal Sensor Capability

The SensAlarm Flex accepts a variety of Plus Series Sensor technologies, which include electrochemical, catalytic bead, and infrared. Sensors can be installed without having to reconfigure or modify the Gas Monitor in any way. When a different Plus Series Sensor is installed in the Gas Monitor the unit reconfigures the system functions to match those of the new sensor. This includes changing all alarm and calibration settings to match those of the new sensor.

1.2.2. Large Display for Ease of Operation

The SensAlarm Flex has a large seven (7) inch LED display for gas concentration and sensor / system notifications. The top section is reserved to display a large one and three quarter inch (1 ¾") gas concentration for the highlighted sensor channel, which can be seen from several feet away. Sensor channels one (1) and two (2) are indicated in the bottom left and right sections of the display accordingly. A blue frame around the sensor channel indicates the selected channel for the top large concentration display.

1.2.3. Non-Intrusive Operation

Six (6) magnetic hall effect switches bellow the display allow full configuration, calibrations and other functions to be performed without opening the Monitor enclosure. A magnetic screwdriver is provided with the Monitor. Access can be password protected to prevent unauthorized access or changes.

1.2.4. Transportable Calibration

Plus Series Sensors have transportable calibration capabilities. Sensors may be calibrated remotely in a shop or at Sensidyne to be installed at the Gas Monitor without any special tools or adjustments. When a new sensor is installed, the Gas Monitor automatically adjusts to recognize the new gas type and range and adjusts system function accordingly.

1.2.5. Predictive Sensor Failure

Predictive Failure is a unique feature that provides the user with an early warning of the pending expiration of a sensor. When the sensor has less than 10% of its life remaining, a warning can be configured to appear on the main display, and can be assigned to activate other fault indicators and output protocols.

Predictive failure is based on sensor age, power on hours, calibration gain and cumulative gas exposure. The user can access Remaining Sensor Life (percent) at any time.

1.2.6. AC & External DC Power Compatibility

SensAlarm Flex has an internal power supply for operation from 100-240 VAC ±10%, 50/60 Hz and rated at 24 VDC, 65 watts output for general purpose configurations only. 24 VDC is used to power the annunciation, so that the Gas Monitor is fully functional on external 24 VDC or internal battery backup when optionally furnished, which is available in both the general purpose and hazardous area certified configurations.

The optional, internal battery backup will power the unit in the event of a line power failure. It provides 30 minutes operation in full alarm and 60 minutes minimum when not in alarm.

1.2.7. Communication Protocols

The Gas Monitor comes standard with 4 to 20mA output, Modbus RS-485 RTU and Ethernet TCP protocols.

1.2.8. Relay Outputs

Four (4) Single Pole, Double Throw (SPDT) 5A relays are standard in SensAlarm Flex. The Relay Printed Circuit Assembly (PCA) inside the Gas Monitor includes LED lights for indication of individual relay activations.

1.3. Factory Installed Options

1.3.1. Second Sensor Interface

SensAlert Flex permits an optional second sensor interface to be installed in the channel-2 or on the right of the Gas Monitor. Just as with the standard channel-1 left sensor interface, any Plus Series Sensor can be utilized in this additional channel location. SensAlert Flex sensor interfaces are intrinsically safe, which permits a faster response with target gases in the atmosphere due to the unneeded use of physical barriers, such as sintered metal disks to protect the sensor or internal electronics from potentially hazardous environments.

1.3.2. Remote Sensors

One or both sensor interfaces can be remote mounted up to one-hundred (100) feet away from the gas monitor. This “flexibility” permits the detection of heavier or lighter than air target gases, and the use of special fixturing such as with use with the Sensidyne Hazardous Area Approved Sample Draw or duct mounting.

The sensor interface is connected without special cable or conduit. Sensidyne furnishes all hardware to remote mount the sensor.

1.3.3. Test-On-Demand™ Gas Generator

The Gas Monitor Test On-Demand™ (ToD) feature allows the gas sensor response to be confirmed quickly and easily. When activated, either manually, or at programmed intervals, the ToD™ cell, which resides in the sensor interface, generates a small gas output which interacts with the gas sensor to verify that it is responsive to gas. This un-manned “bump test” does not replace recommended calibration procedures. The purpose of this feature is to provide a higher level of system operating confidence by confirming that the sensor responds to gas. Environmental conditions or ToD cell depletion can cause this test to be degraded or fail. A low mA signal for 30 seconds will indicate failure or a fault output may also be assigned.

1.3.4. Stack Strobe Lights

SensAlarm Flex offers an optional stack light assembly where 360° alarm / fault visual indication is required. The stack light can be configured with up to four (4) visual indicators, which include red, yellow, blue and green. The stack light will follow the visual indication of the front panel LED strobe and can be configured to remain steady or flash.

1.3.5. Internal Battery Backup

An integral battery backup option with internal charging is offered to sustain SensAlarm Flex operational functionality in the event of power outage. If a gas alarm occurs during battery backup, a minimum of 30 minutes operation is available. The Gas Monitor will operate for longer periods of time if no alarms are present, and depending upon the installed sensor type. Strobe indicators are limited to flash only during battery backup operations to extend the available operational time.

1.3.6. Additional Relay Outputs

An additional Four (4) Single Pole, Double Throw (SPDT) 5A relays can be added to SensAlarm Flex. They are identical in operation to the standard relays in that the PCA includes LED lights for indication of individual relay activations, but relays can be configured to function independently.

1.4. SensAlarm Flex Components

1.4.1. Sensor Interface Assembly

The sensor interface assembly is intrinsically safe, and contains the electronics that operate and house Plus Series Sensors and the optional Test-on-Demand™ cell.



1.4.2. Plus Series Sensor

Plus Series Sensors are available in a variety of sensor technologies for detecting Toxic, Oxygen, and Combustible gases. The Plus Series Sensor is discussed in greater detail in Section 1.4.16. The sensor gasket seals the sensor inside the sensor holder.



1.4.3. Test-on-Demand

The optional Test-on-Demand™ (ToD™) gas generating cell provides a method for periodic sensor response verification (programmed or manually activated). The T-O-D gasket seals the generating cell inside the sensor holder.



1.4.4. Sensor Holder

The sensor and ToD™ gas generating cell are housed in the Sensor Holder. The sensor holder is easily installed and removed via the retaining ring located on the sensor interface assembly. The sensor holder is black anodized Aluminum, optional gray PVC, or 316 Stainless-Steel.



1.4.5. Rainshield & Moisture Barrier

The optional Rainshield protects the sensor and ToD cell from liquid intrusion due to rain, splash-back, or unintentional washdown, and offers an optional highly recommended calibration port. The Moisture Barrier is an optional component for a higher level of moisture protection. Target gases penetrate the Moisture Barrier, where moisture does not. The Moisture Barrier is required for use with IR sensor methods.



1.4.6. Calibration Plug

The Calibration Plug secures through a friction fit into the sensor shield at the bottom of the sensor holder, which ensure a leak-tight introduction of calibration gas standards. If not using the Rainshield with calibration port, the Calibration Plug is a required accessory.



1.4.7. Relays

Four (4) Standard Single Pole, Double Throw (SPDT) 5A relays are included in SensAlarm Flex. The option for an additional four (4) relays is available. The Relay Printed Circuit Assembly (PCA) inside the Gas Monitor includes LED lights for indication of individual relay activations. Once the front panel is opened, the relay LED lights and wire termination plugs are easily accessible.

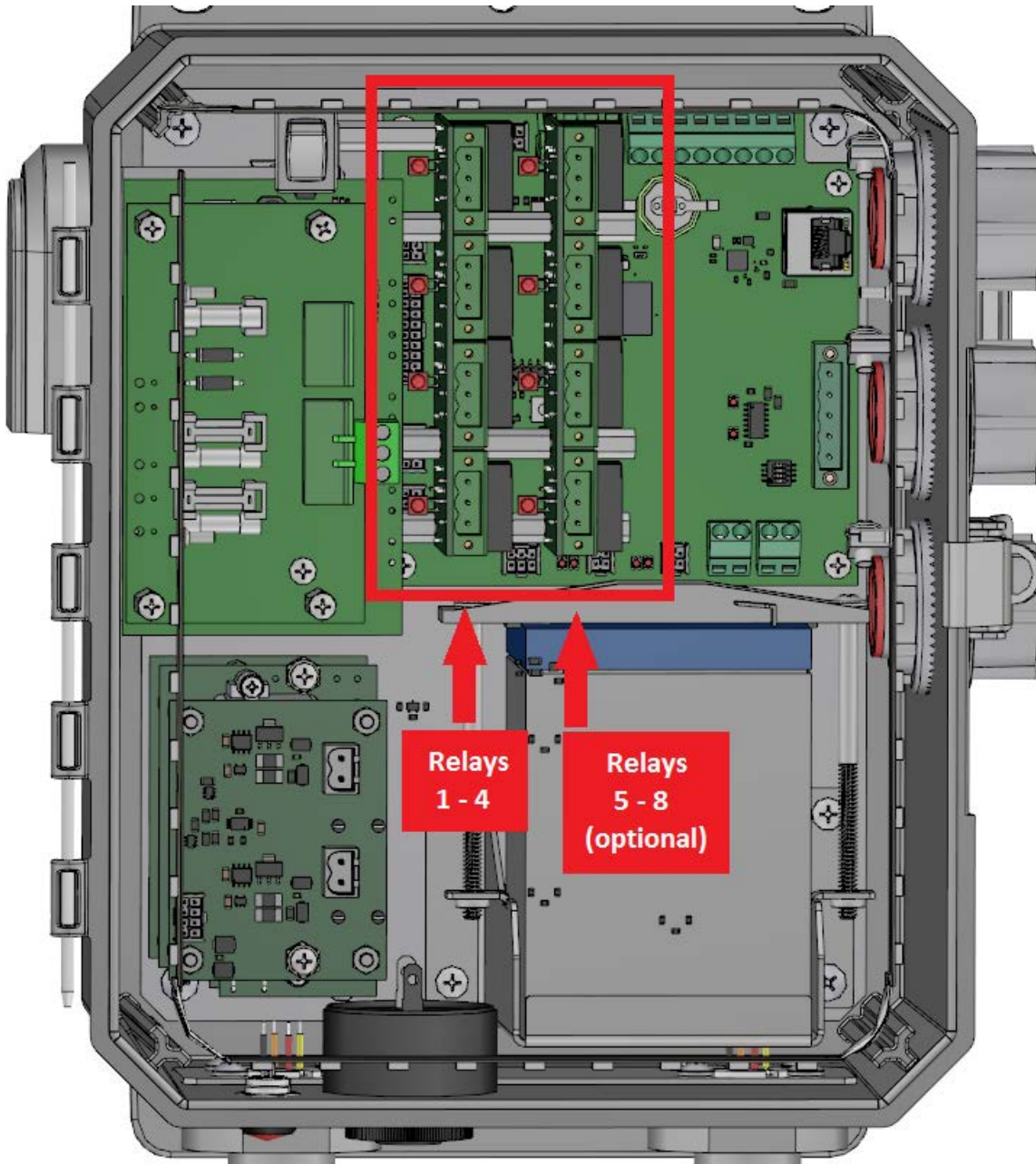

1.4.8. Modbus

SensAlarm Flex includes both Modbus TCP and RTU (RS-485) standard. Both are easily accessible and are located on the right of the Main PCA. Modbus TCP accepts a standard RJ-45 Ethernet cable. Modbus RTU can be wired in half duplex (2-wire) or full duplex (4-wire).

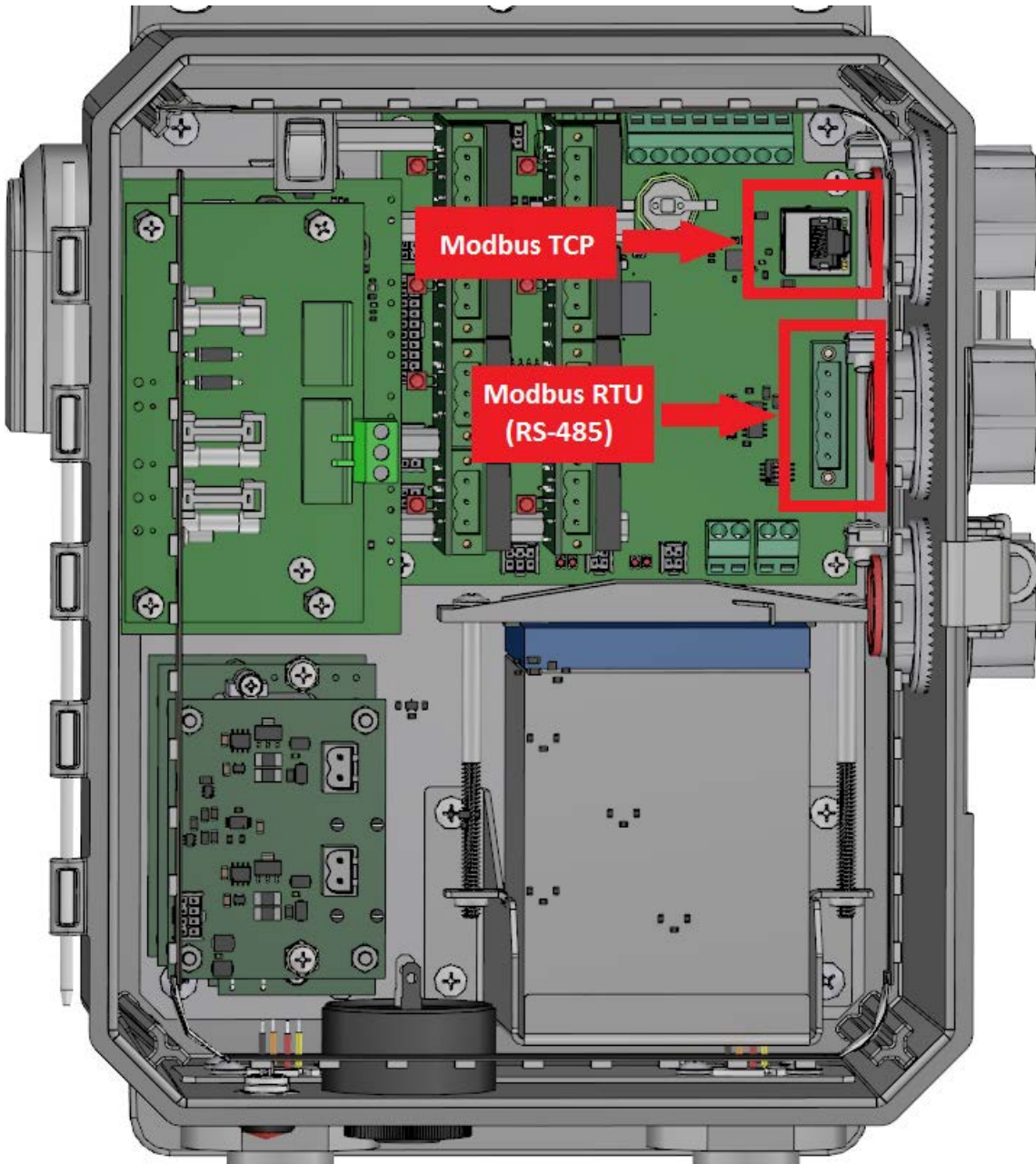

1.4.9. 4 to 20 mA Output

The standard 4 to 20mA outputs are located in the bottom left hand side of the enclosure. CH-1 represents the Left Sensor Interface, and CH-2 the right. CH-2 only functions when SensAlarm Flex is configured with the optional second Sensor Interface.

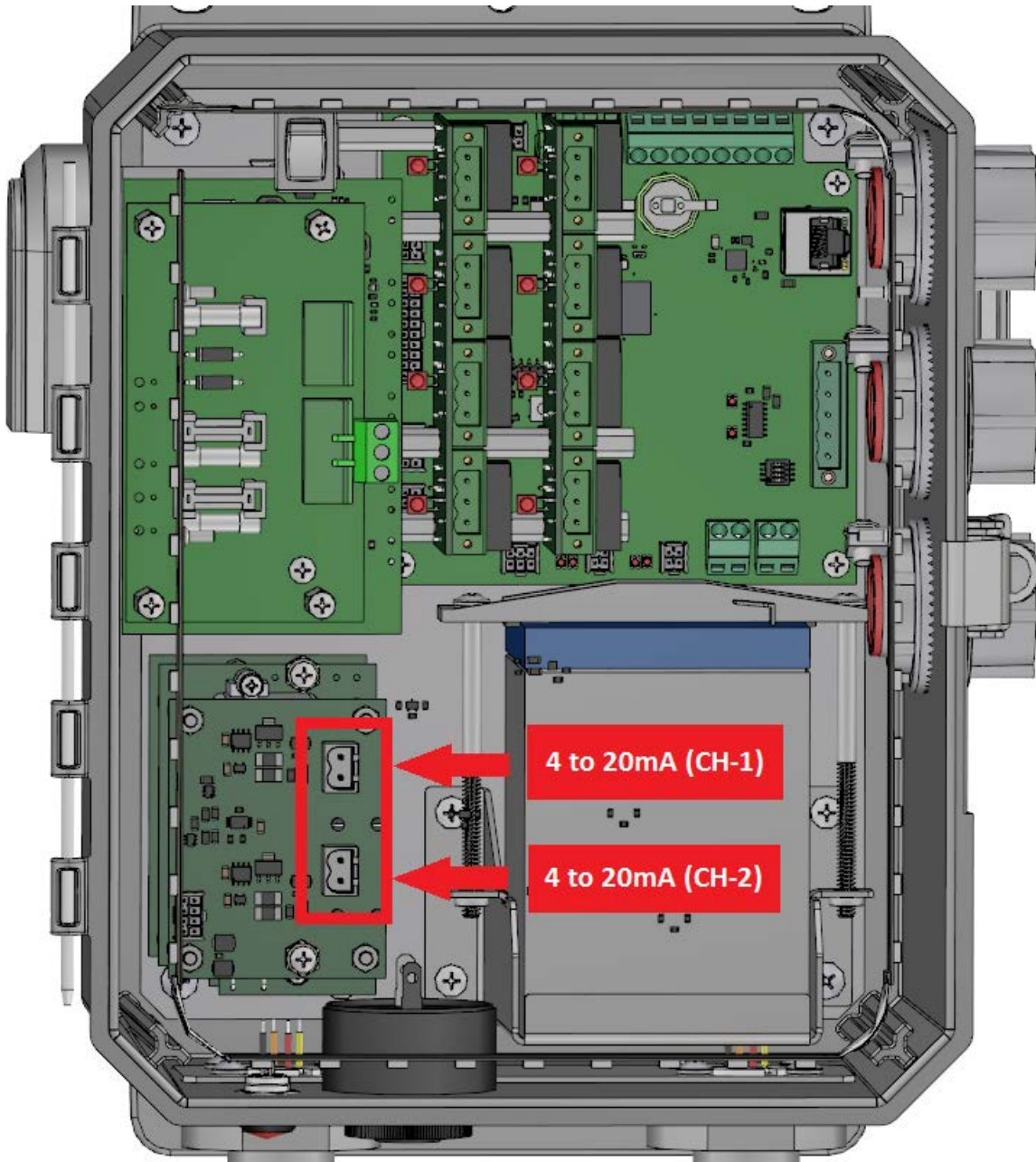

1.4.10. Battery Backup

The Gas Monitor offers an optional Battery Backup, which will power the unit in the event of a line power failure. It provides 30 minutes operation in full alarm and 60 minutes minimum when not in alarm. While line power is available, the Battery Backup remains in a continuous trickle charge. If SensAlarm Flex is configured with Battery Backup, it is located in the bottom right hand side.

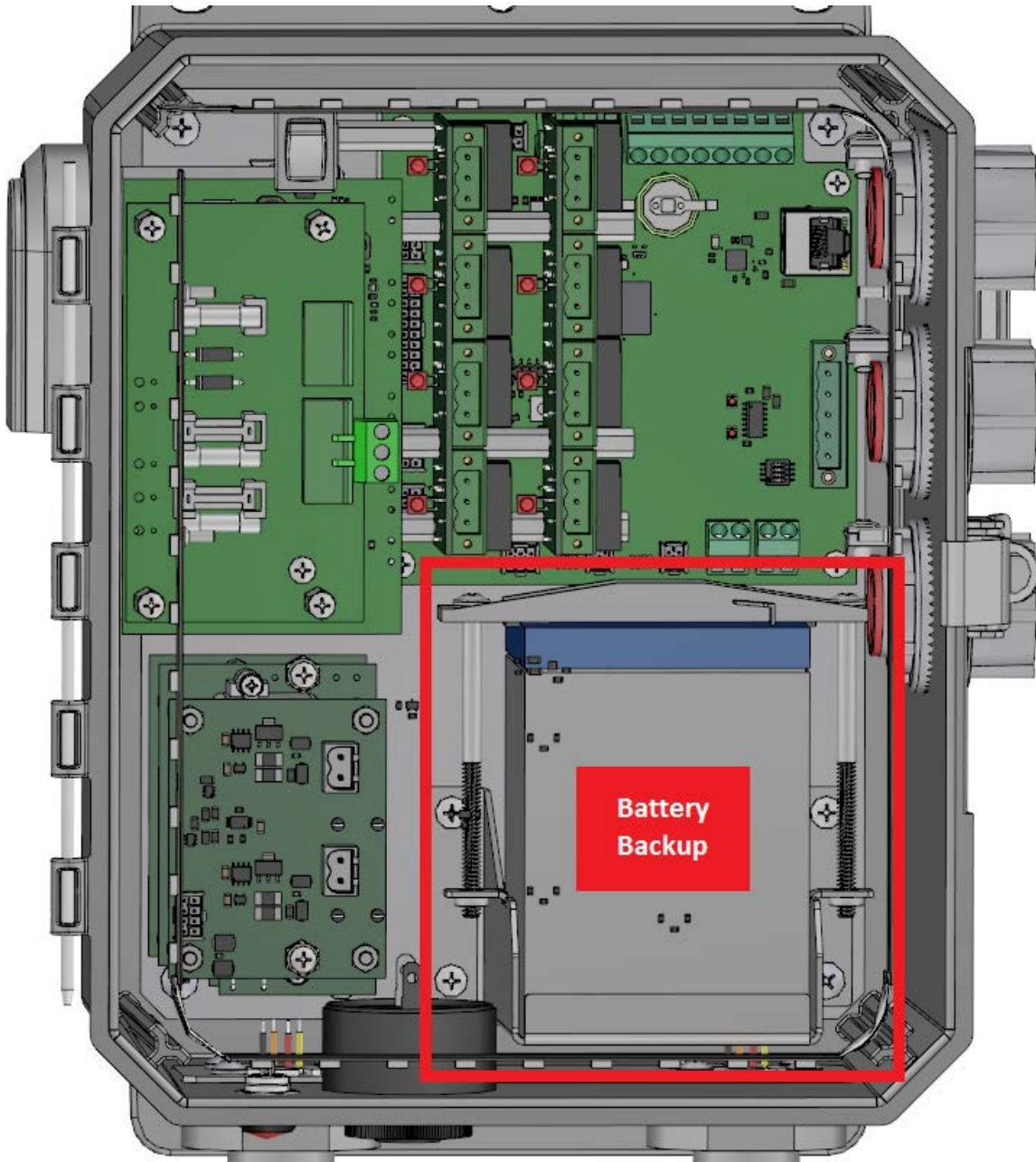

1.4.11. Horn and Silence Pushbutton

SensAlarm Flex offers a standard 95dB Horn that can be silenced by an externally mounted pushbutton that conforms to ISA Alarm Sequence 3A. The Silence Pushbutton also resets latched relays once the Alarm or Fault condition is clear.

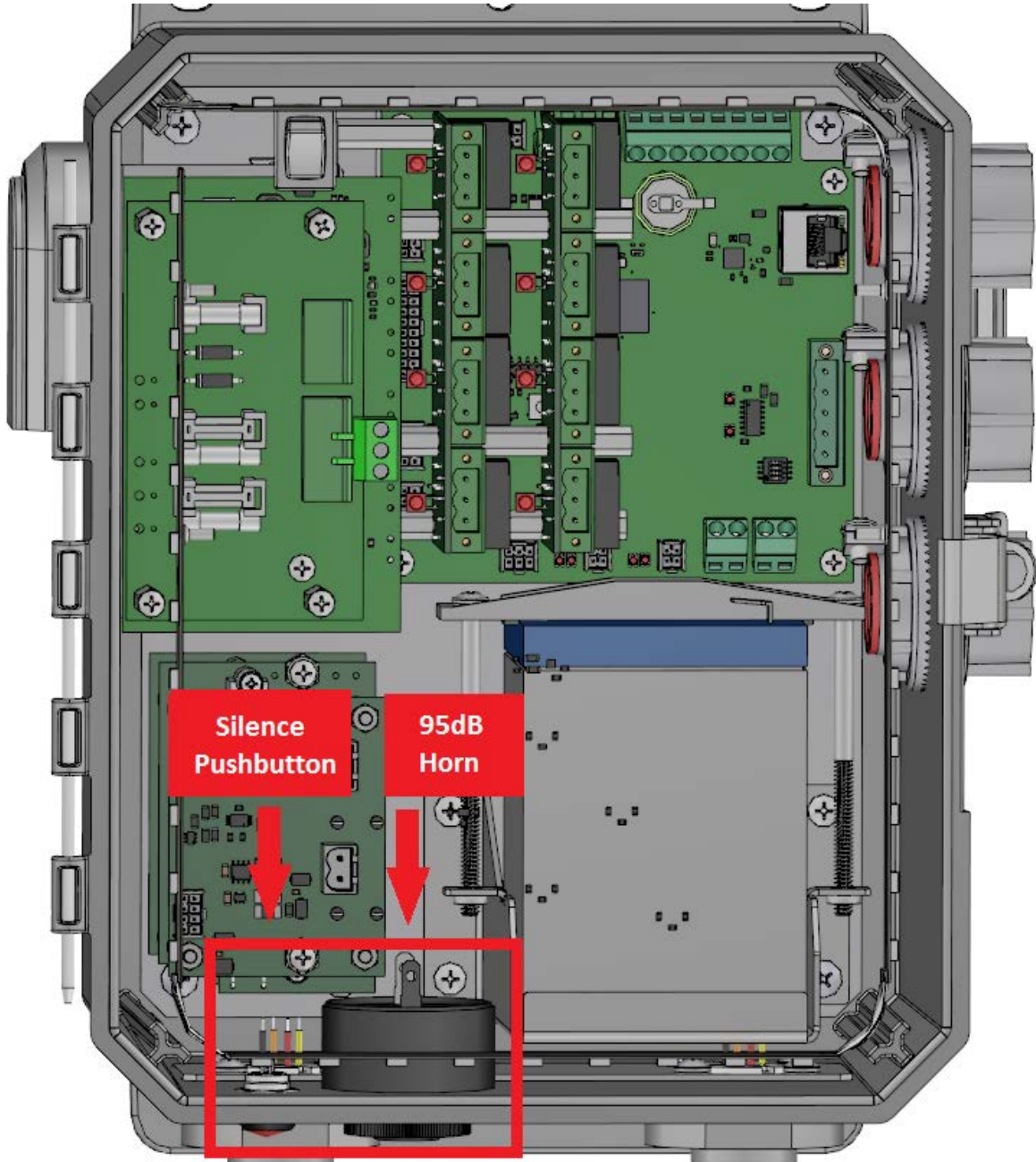

1.4.12. Front Panel LED Strobe

The Universal Gas Monitoring Systems includes as a standard feature the “All-In-One” system requirements of visual alarm / fault notification. Unlike traditionally used stack lights, the front panel strobe does not take up unnecessary space, and ensures the Gas Monitor maintains the smallest footprint possible. The Front Panel LED Strobe offers green, red, yellow and blue visual notifications.

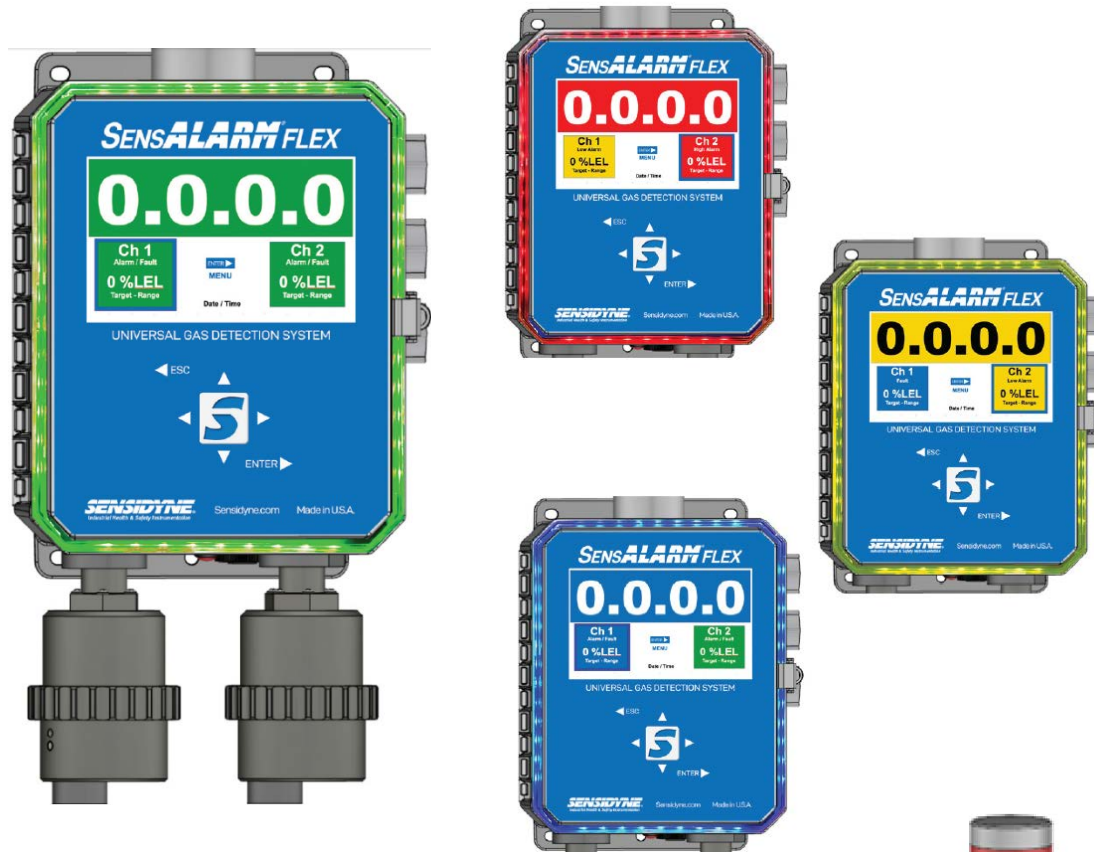

1.4.13. Stack Light (General Purpose Only)

When 360° alarm notification visibility is required, SensAlarm Flex offers an optional Stack Light that can be configured with either one, two, three or four strobes. The Stack Light will follow the Front Panel LED Strobe configuration.



1.4.14. SensAlarm Flex Components (Summary)

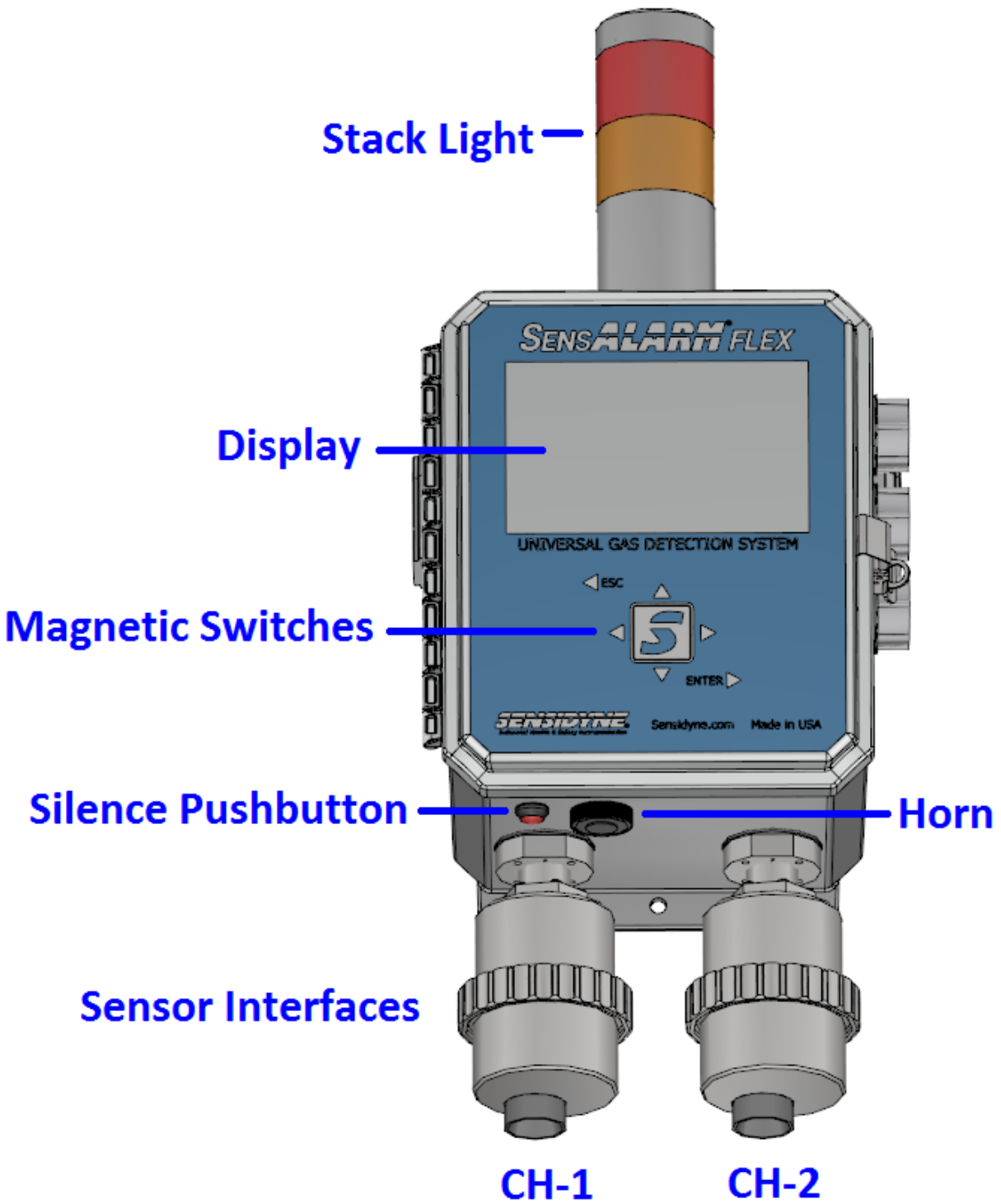

1.4.15. Display (Main Screen)

The seven-inch (7") Display is segmented into three (3) main sections. The top section is reserved to display a large one and three quarter inch (1 ¾") gas concentration for the highlighted sensor channel, which can be seen from several feet away. The concentration will be in Parts Per Million (PPM), Percent Lower Explosive Limit (%LEL) or Percent Volume (%Vol) depending on the sensor type. Sensor channels one (1) and two (2) are indicated in the bottom left and right sections of the display respectively. A blue frame around the sensor channel indicates the selected channel for the top large concentration display. The two (2) bottom sensor channel sections display the current gas concentration, the sensor type, and the presence of any alarm or fault conditions. The background colors of all the sections will follow the strobe configuration, but for reference the below examples assume Green is Normal, Blue is Fault, Yellow is Low Alarm, and Red is High Alarm. However, these can be configured in the application required manner, except Green that will always reflect a normal condition.

NOTE: The Display and 4-20 mA current loop are suppressed to 0 value (4 mA) for all values below 3% Full Scale until -10% Full Scale at which point a Sensor Fail Fault is indicated.

NOTE: Display Value = (% Full Scale) x (Full Scale Value).

Examples:



1.4.16. Sensor Types

WARNING: DO NOT attempt to install any other sensor type into a SensAlarm Plus except those manufactured by Sensidyne and intended for this product.

Sensors should be hot-swapped only when the Normal Operation Mode screen is displayed.

NOTE: Maximum response time delay is sensor response time + sensor polling rate (1 second) + Head polling rate (1 second) + Display update rate (1 second).

NOTE: A complete list of available sensors, sensor specifications, interferences, and calibration equipment can be found on line at www.sensidyne.com.

1.4.16.1. Infrared

Infrared sensors are used to detect Combustible gases or vapors and Carbon Dioxide.



1.4.16.2. Catalytic Bead Combustible

Catalytic Bead sensors are used to detect Combustible gases and vapors.



1.4.16.3. Sealed Electrochemical

Sealed electrochemical sensors are used to detect Toxic gases.



1.4.16.4. Oxygen

Oxygen sensors are used to monitor ambient Oxygen levels to detect Oxygen Deficiency.



1.4.16.5. Sensor Assembly

The sensor assembly consists of a gas sensor attached to a Printed Circuit Assembly (PCA). An EEPROM on the PCA contains essential sensor identification information that is communicated to SensAlarm Flex during sensor installation. This information allows the sensor to be calibrated in the shop or at Sensidyne and hot-swapped in the field without further calibration.

NOTE: Oxygen and Infrared Sensors must be calibrated at the altitude of intended use.

ETO, NO and HCl sensors are shipped attached to a battery to prevent extended sensor warmup times. Batteries are designed to maintain biasing for up to 90 days. Battery boards should remain attached to the sensor until just prior to sensor installation, and should be removed in non-hazardous (non-classified) areas. The sensor can be unplugged from the battery board for up to five (5) minutes without significant warmup time. Biased sensors unpowered for less than five (5) minutes, may take 2 minutes to complete warmup once installed in the Gas Monitor. Significant warmup time may be encountered with biased sensor unpowered for greater than five (5) minutes.

2. INSTALLATION

2.1. Location

Monitoring effectiveness will be dependent on appropriate placement of the Sensor. The SensAlarm Flex should be mounted in proximity to any potential target gas leak sources. Local Sensors are those installed directly to SensAlarm Flex, and in this configuration are generally used where entire rooms should be monitored, often for oxygen depletion.

Sensors may also be mounted remotely from the SensAlarm Flex, and is generally used to accommodate target gases that are heavier or lighter than air, or where there are mechanical connections in the target gas delivery system, or for exhaust duct monitoring.

The SensAlarm Flex itself is often conveniently located near entrances where users can access it. Expert consultation may be necessary to determine the most appropriate location for optimum monitoring. In all circumstances, the plant safety officer or other appropriate personnel should be consulted before installation.

Site determination, at a minimum, must consider the following factors:

- Most probable location(s) of a hazardous target gas leak
- Physical properties of the target gas (heavier or lighter than air)
- Air movement due to ventilation or predominate wind direction
- Environment conditions such as vibration, temperature, and humidity
- Presence of interferent or cross sensitive gases (reference appropriate Sensor datasheet)
- Access for routine preventive maintenance

2.2. Code Compliance

The Uniform Fire Code and International Fire Code both have evacuation requirements for buildings during emergency conditions. These mainly concern egress safety and routes, evacuation time, and include emergency lighting specifications. Local authorities may further define or detail these codes.

If a gas detection system alarm can result in an evacuation, or Fire Department notification, the gas detection system may require battery or Uninterrupted Power Source (UPS) back-up power. The code requirements for your facility will dictate the required duration for power backup situations. These requirements provide for operational conditions during power failures, and enough time to furnish valuable status information to users and emergency responders.

SensAlarm Flex is available with an optional battery back-up to provide 60 minutes of non-alarm operation and at least 30 minutes of operation under alarm conditions.

2.3. Gas Monitor Installation

NOTE: Always refer to the NEC and local electrical codes to ensure compliance for proper installation.

The SensAlarm Flex Gas Monitor mounts directly to a wall or vertical platform via four (4) mounting holes located above and below the enclosure. Additional mounting holes are available in the center of the enclosure mounting tabs for additional support if required. Placement should be in conspicuous areas that are easily seen. The Gas Monitor must be mounted to a backing that will properly support the weight of the unit. Three (3) ¾" Rigid NPT / IMC grounding hubs are provided for wiring access. Line power should not be run in low voltage control conductor raceways. The top Rigid / IMC grounding hub is

SensAlarm Flex – Universal Gas Detection System

intended for use with high voltage line power raceways. The middle Rigid / IMC grounding hub is intended for use for relay wiring. The bottom Rigid / IMC grounding hub is intended for use with DC power inputs and 4-20mA outputs. Metal conduit should be used to achieve maximum EMI / RFI immunity. The Gas Monitor must be mounted vertically ($\pm 5^\circ$ from center) with the sensor assemblies pointing down.

NOTE: The Gas Monitor has been evaluated to EN50270 for electromagnetic compatibility. It is recommended to use shielded interconnect cables for this device.

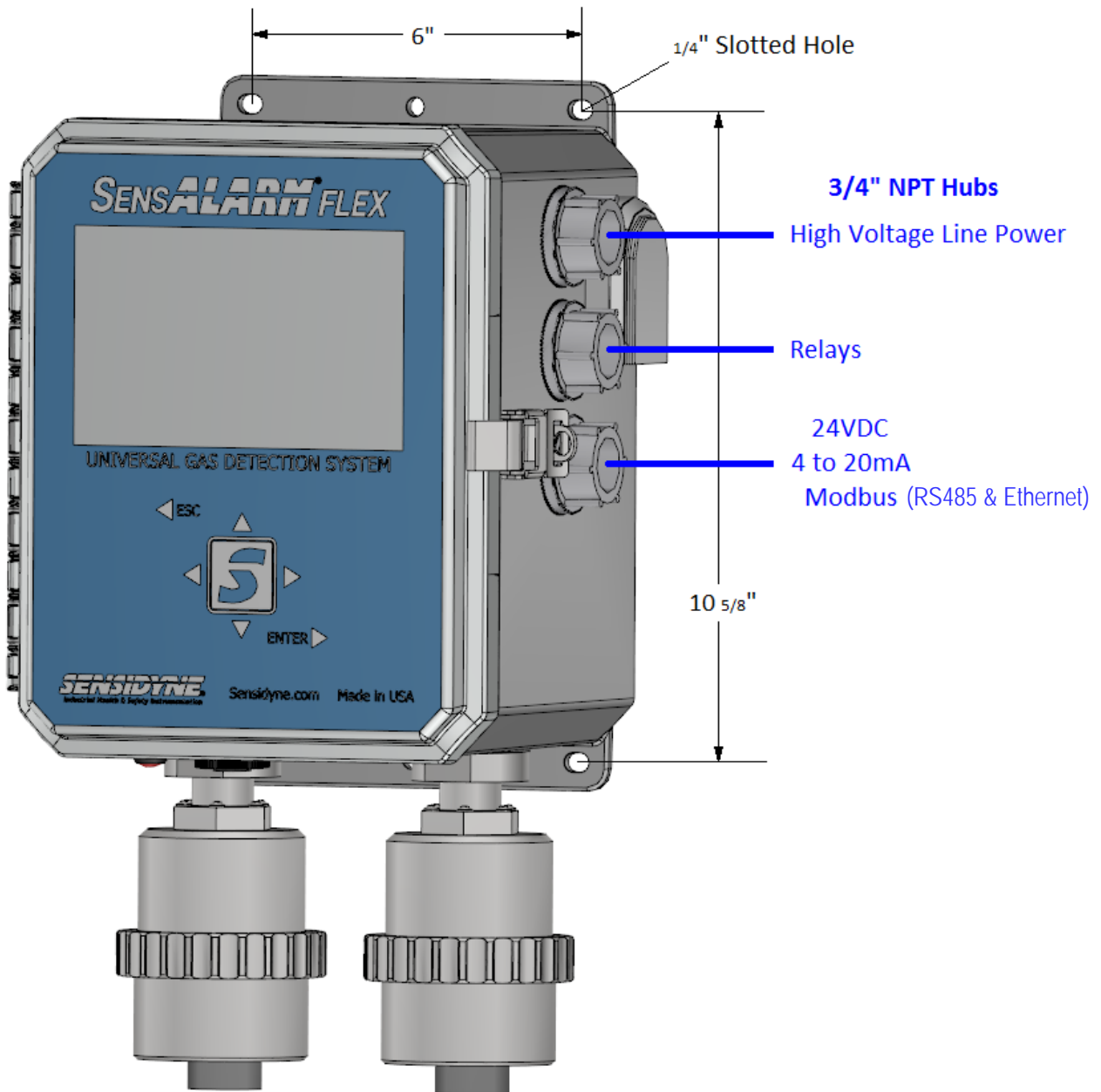

2.3.1. AC Power

When wiring the Gas Monitor to a permanent AC source, the AC source circuit breaker and / or switch must be IEC approved. The circuit breaker and / or switch must be near the unit and marked as the disconnect device. The minimum current rating must be 10A. Minimum wire size for line power conductors is 18 AWG. Use only U.L. listed conduit and hubs that are the same or better environmental rating as the enclosure.

- 2.3.1.1. Unlatch and open the Gas Monitor cover.
- 2.3.1.2. Confirm that the AC power is not energized, and thread the wires through the top Rigid / IMC grounding hub. A cable that totally encases these conductors is recommended. Make certain to tighten the Rigid / IMC grounding hub sufficiently to ensure a moisture resistant seal to the cable conduit.
- 2.3.1.3. Make certain the Rigid / IMC grounding hub is secured tightly to the Gas Monitor enclosure.
- 2.3.1.4. Make certain the wires are properly secured to the AC Terminal Block. See the below figure for location.

NOTE: AC (Earth) ground must terminate on TB1 ground terminal to prevent electric shock hazard.

2.3.2. DC Power

- 2.3.2.1. Unlatch and open the Gas Monitor cover.
- 2.3.2.2. Confirm that the DC power is not energized, and thread the wires through the bottom Rigid / IMC grounding hub. A cable that totally encases these conductors is recommended. Make certain you tighten the Rigid / IMC grounding hub sufficiently to ensure a moisture resistant seal to the cable conduit.
- 2.3.2.3. Make certain the Rigid / IMC is secured tightly to the Gas Monitor enclosure.

2.3.2.4. Make certain the wires are properly secured to the DC terminal block. See the below figure for location.

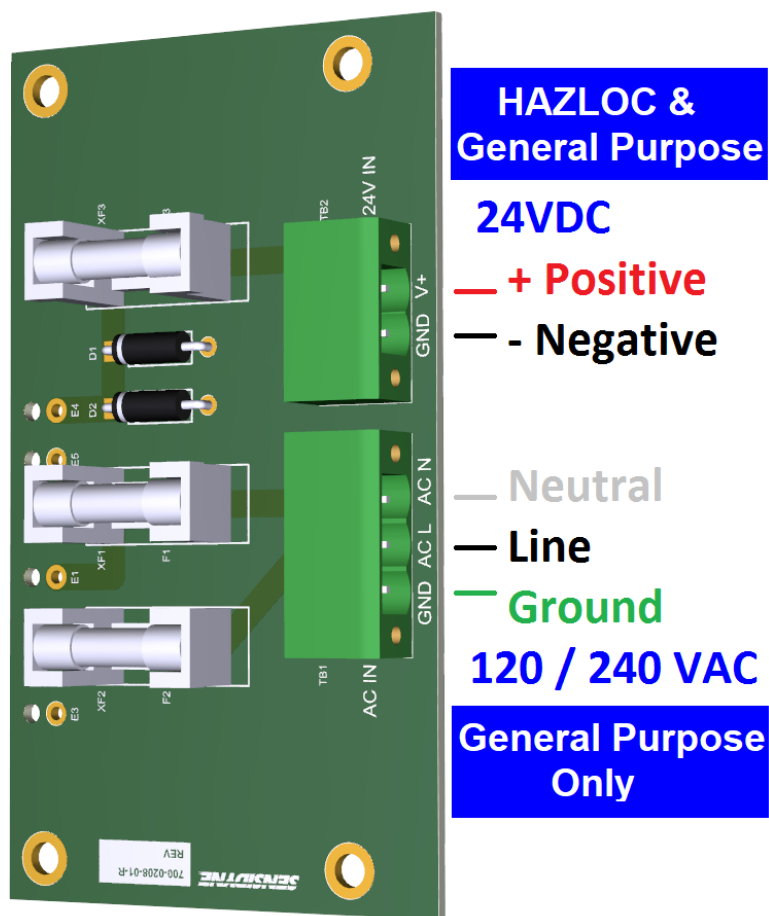

2.3.3. 4 to 20 mA

The SensAlarm Flex 4 to 20mA output is Source (only) and not Sink. Both a positive and negative conductor are required for each individual Sensor Interface Channel. See the below figure for the proper conductor termination requirements.

- 2.3.3.1. Verify that the conduit and the Gas Monitor are properly connected.
- 2.3.3.2. Unlatch and open the SensAlarm Flex cover.
- 2.3.3.3. Verify that the total resistance of the wiring does not exceed the allowable loop resistance.
- 2.3.3.4. Thread the wires through the bottom Rigid / IMC grounding hub. A cable that totally encases these conductors is recommended. Make certain you tighten the Rigid / IMC grounding hub sufficiently to ensure a moisture resistant seal to the cable conduit.
- 2.3.3.5. Remove the terminal jack from the 4 to 20mA PCA channel to be terminated (CH-1 is the top terminal and CH-2 the bottom. CH-1 is the left sensor interface and CH-2 the right). Connect the 4 to 20mA conductors to the terminal jack. See the below figure for location.
- 2.3.3.6. Connect the terminal jack into the 4 to 20 mA PCA port.
- 2.3.3.7. Close the Monitor cover. Secure the cover by closing the quick-release latch.

NOTE: 4-20 mA signal is $((\% \text{ Full Scale}) \times 16) + 4 = \text{mA output}$. Faults typically 3 mA.

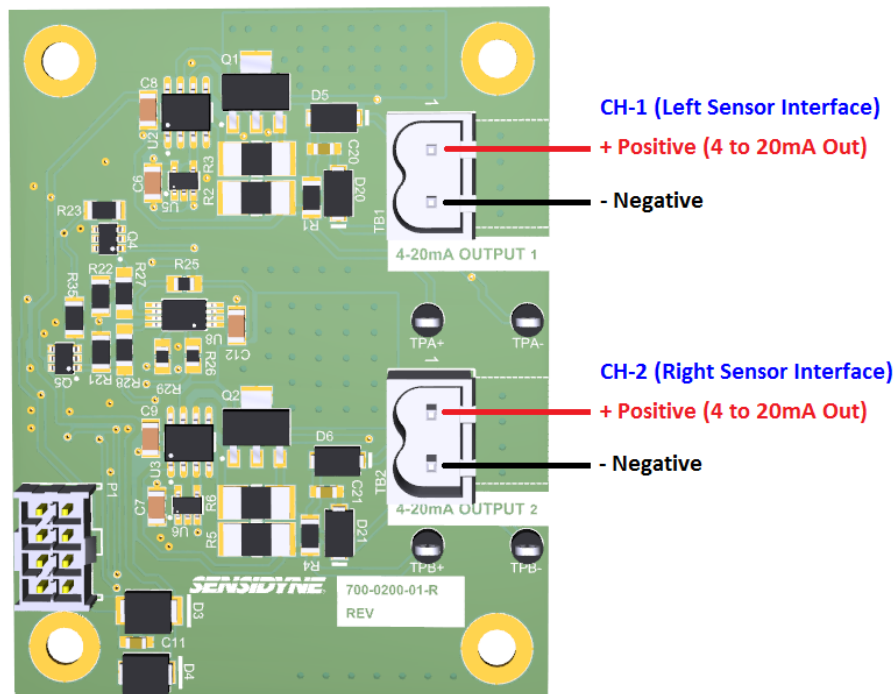

2.3.4. Relays

- 2.3.4.1. Relays are configured “normally de-energized” from the factory. Thread the conductors through the middle Rigid / IMC grounding hub. A cable that totally encases these conductors is recommended. Make certain you tighten the Rigid /

IMC grounding hub sufficiently to ensure a moisture resistant seal to the cable conduit.

2.3.4.2. Thread all relay conductors through the single large Ferrite Bead supplied with the Gas Monitor.

2.3.4.3. Remove the terminal jack from the Relay PCA and terminate the conductors to the jack. Refer to the below figure for location.

2.3.4.4. Secure the jack into the Relay PCA.

2.3.4.5. Repeat as necessary for the additional relays and secure the enclosure cover.

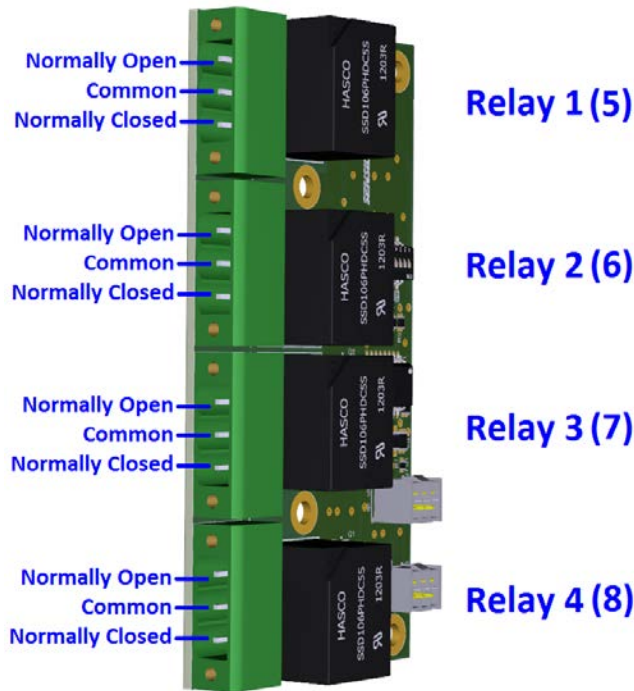
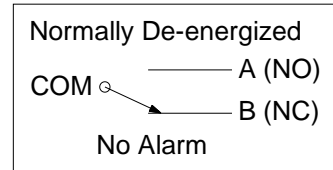

2.3.5. Modbus

2.3.5.1. SensAlarm Flex offers both Modbus TCP and RTU (RS-485) standard. Modbus RTU accommodates both two (2) and four (4) wire half-duplex and full-duplex infrastructures. Dip switches configure end of line terminating resistors, without the incorporation of these manually. The Modbus wire termination jacks are located on the Main PCA at the top right hand of the enclosure. Refer to the below figure for wire termination and dip switch setting details.

2.3.5.2. Wire Recommendations

- 20-24 AWG Twisted Pair, Overall Shielded
 - 2 Wire - Single Pair
 - 4 Wire - Two Pair

- Belden 9501, 9502, 8451, 8761, 1419A
- Alpha Wire 5471C, 5472C

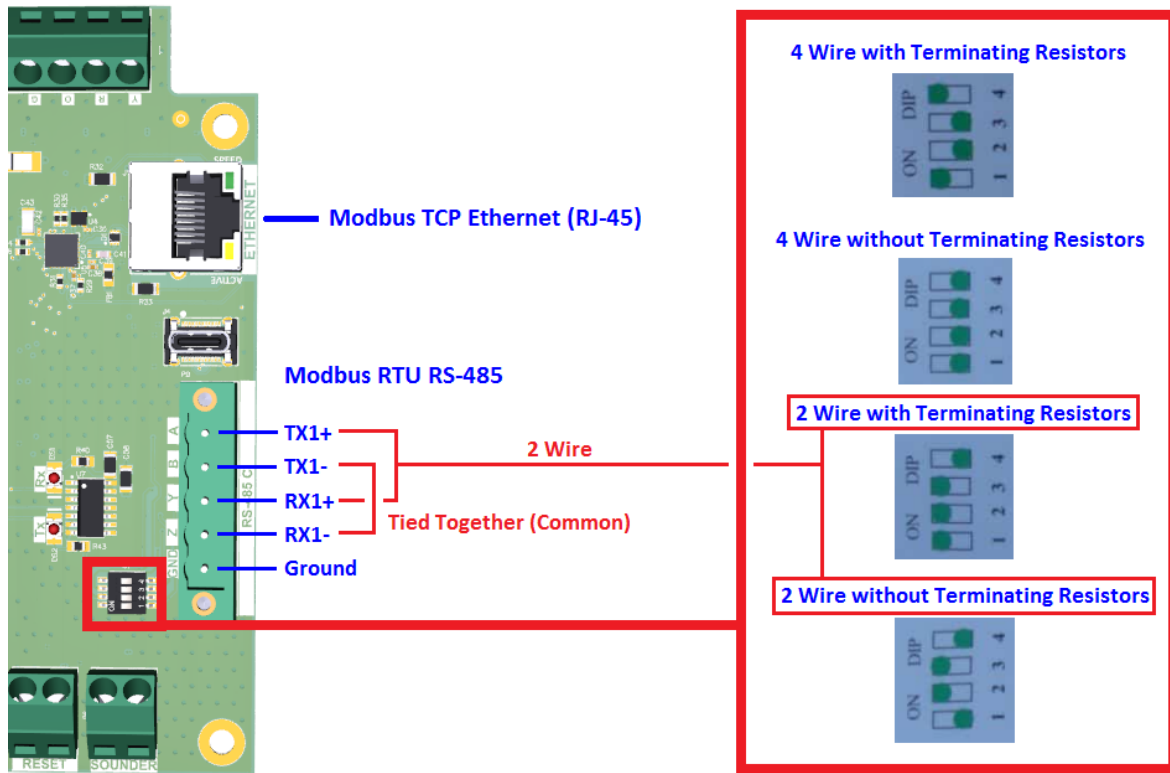

2.3.6. Field Wire Terminating Locations (Summary)

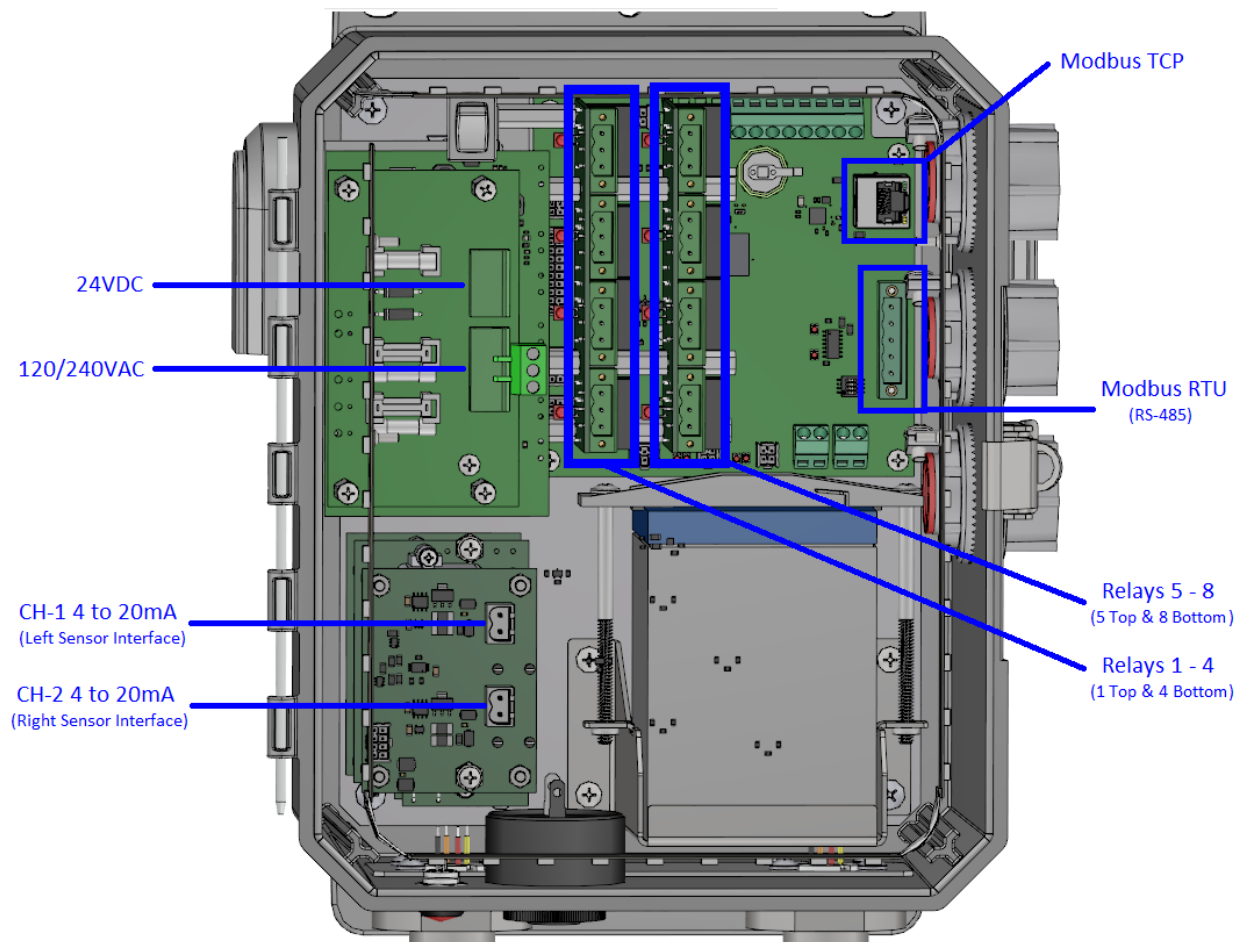

3. STARTUP

This section contains information necessary to perform the initial start-up of the SensAlarm Flex Universal Gas Monitor. The magnetic screwdriver provided with your Gas Monitor will be required to perform these steps.

3.1. Power On

- 3.1.1. Before turning the unit on after Line Power has been terminated to the Power PCA, connect the Positive Battery Lead if your Gas Monitor was purchased with Battery Backup.
- 3.1.2. Once connected, move the rocker switch located at the top left hand of the enclosure to the On (1) position.
- 3.1.3. The Main Display will boot-up with a splash screen indicating the Main and Sensor Interface(s) Firmware Revisions. This information is easily accessible after boot-up.



- 3.1.4. After boot-up, the SensAlarm Flex Main Screen will be displayed. The Channel Information located in the bottom left (single Sensor Interface) and / or bottom right (second Sensor Interface) will indicate “Missing Sensor” in the Alarm / Fault Section.



3.2. Sensor Installation

- 3.2.1. To install a Sensor, unscrew the retainer ring (turn left to right) and remove the sensor holder by pulling downward.

NOTE: Ethylene Oxide (ETO), Nitric Oxide (NO) and Hydrogen Chloride (HCl) sensors utilize a battery board for transportation and storage to maintain the sensor bias, which must be removed to install the sensor. To avoid an excessive sensor warm-up time attempt to install the sensor as quickly as possible once removed from the battery board. Biased sensors may require an extended period of time to stabilize if they have been disconnected from the battery board for more than five (5) minutes and may take several hours to return to zero once plugged in and powered up.

- 3.2.2. Install the Plus Series Sensor by inserting the sensor in the sensor interface using the two larger mounting posts as guides. Hold the sensor by its outside edges. If force is required to engage the connector, press on the green circuit board. To avoid damaging the sensor, do not apply pressure to the face of the sensor. To remove the sensor, pull on the circuit board edges rather than the sensor.

- 3.2.3. Once the SensAlarm Flex recognizes the sensor assembly, a “Warm Up” message appears on the display for 60 seconds in the Alarm / Fault section for the associated Channel before the Gas Monitor begins normal operation. As shipped, the Sensor Holder has a plug in the Test-on-Demand™ well. Remove this plug if a Test-On-Demand™ cell will be installed. Place the gasket inside the sensor holder. Ensure the O-ring is in the sensor holder and install up over the mounted sensor by aligning with the mounting posts. Rotate the retaining ring on the assembly from right to left to secure the holder. Hand tighten the Sensor Holder Ring, and then tool tighten at least 0.375” or 3/8” or greater until the ring cannot be tightened further.

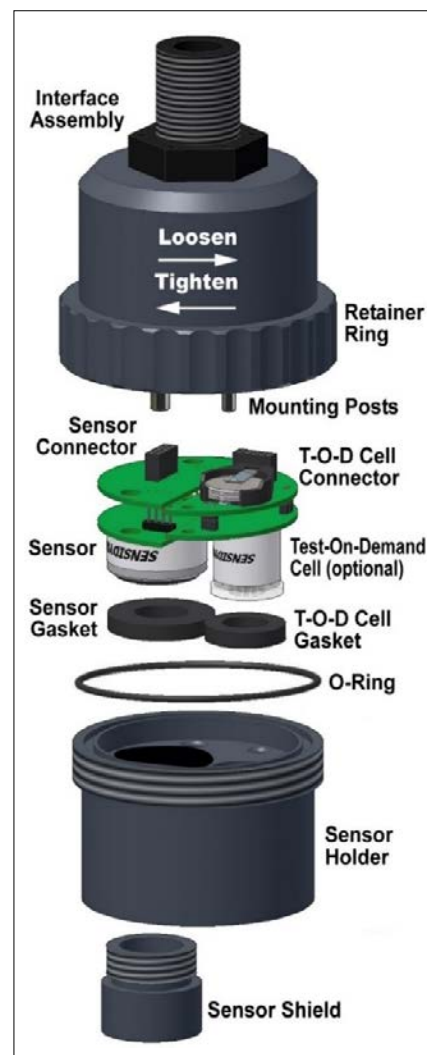

WARNING: After power has been applied to the Gas Monitor, sensor stabilization occurs (lasting approximately 1 hour). During this time the sensor reading may fluctuate, possibly causing the alarms to activate.

WARNING: With the initial installation of a sensor, the default alarm and fault values will be configured. After the initial sensor installation, replacement sensors of the same type will not change customized alarm or fault settings. However, if a new sensor type is installed, the alarm and fault values will be returned to the default settings.

- 3.2.4. Allow the Gas Monitor to stabilize at least one (1) hour before calibrating the sensor. The Main Display reading should be near “0” (or 20.9 %vol for ambient Oxygen sensors). After stabilization is complete indicated by a constant displayed value, go to the next Section and perform sensor calibration starting with the Zero Calibration, even if the display is “0”.

4. OPERATING FUNCTIONS

In this Section, details the procedures for performing common operating functions. For complete information on the structure of the SensAlarm Flex operational menu system, refer to Menu Structure Section.

4.1. Calibration

Your SensAlarm Flex Universal Gas Monitor is tested and calibrated at the factory prior to shipment. However, this product must be calibrated prior to initial use and at regular intervals in accordance with this User Manual to ensure proper operation.

WARNING: Failure to calibrate and operate this product in accordance with this User Manual may result in property damage, severe personal injury, or death.

After installation and stabilization of the gas Monitor, qualified personnel must verify calibration by applying Sensidyne zero and span gas standards. This procedure should be performed at initial commissioning and then repeated thirty (30) and sixty (60) days thereafter, with deviations in zero and span recorded. The gas Monitor should then be calibrated at intervals dependent on the application, but no less often than once every ninety (90) days, with exception to infrared (IR) sensors, which have a maximum one hundred eighty (180) day calibration interval.

NOTE: Sensors must always be calibrated upon installation and after a gas alarm.

For further information on industry standards for sensor calibration, please refer to Recommended Practice for the Installation, Operation, and Maintenance of Combustible Gas Detection Instruments (ANSI / ISA TR12.13.02-2003) published by the ISA.

For a list of calibration equipment available for calibrating the SensAlarm Flex Gas Monitor see the Calibration Equipment Section.

Always:

- Allow the Gas Monitor to stabilize with power applied for at least one (1) hour before performing any calibration.
- Set the calibration equipment up according to the instructions with the equipment.
- Zero the sensor prior to every Span calibration.
- Refer to the Sensor Data Sheet that came with your sensor for any special instructions.
- Refer to the Sensor Data Sheet for humidity and temperature specifications.
- Use Sensidyne Certified Calibration Gas Standards.
- Use of non-Sensidyne calibration gas standards is AT YOUR OWN RISK.
- Perform calibrations at normal environmental conditions and altitudes.
- Calibrate in a well-ventilated area.
- Avoid breathing any fumes or vapors as they are hazardous to your health.
- Maintain an accurate and up-to-date Calibration Record Log.

SensAlarm Flex – Universal Gas Detection System

4.1.1. To begin Calibration, select ENTER on the Normal Operation Display to bring up the Main Menu. SensAlarm Flex does not leave the factory with Password enabled, but if Password is enabled the first screen requires a valid three (3) digit entry before access to the Menu structure is permitted.



4.1.2. If Password is disabled or after valid entry, the user selects the Sensor Interface Channel to be calibrated.

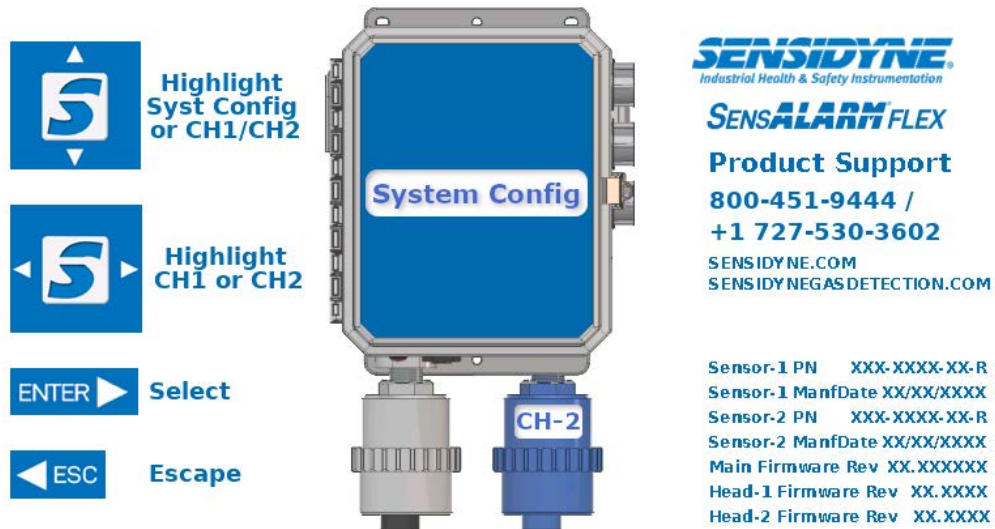

4.1.3. Choose Calibration Mode by Arrowing to the right. The Calibration submenus will automatically be displayed, which are:

- Zero Transmitter
- Calibrate
- Previous Cal Info
- Set Cal Gas Conc. (Concentration)
- Sensor Adjustment

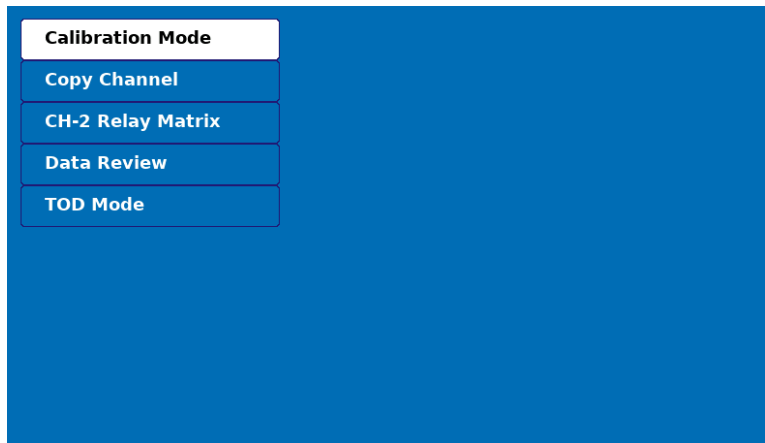

Equipment needed for this section:

- Sensor Data Sheet
- Magnetic Screwdriver (provided)
- SensAlert Flex Calibration Plug
- Calibration Gas Regulator
- Tubing:
 - Tygon® for non-reactive gasses
 - Teflon® for Chlorine, Ammonia, Hydrogen Chloride, Hydrogen Fluoride, Hydrogen Cyanide, Nitrogen Dioxide, Phosgene, Sulfur Dioxide, and Ethylene Oxide.
 - (See the Sensor Data Sheet for additional tubing requirements)
- Sensidyne Calibration Gas Standards are highly recommended. Not all calibration gas suppliers are equal. Sensidyne Calibration Gas Standards utilize cylinders that are specially treated to ensure the quality of the gas to be applied.

WARNING: Use of non-Sensidyne calibration gas is AT YOUR OWN RISK.

NOTE: During calibration, the 4–20 mA signal is locked at 4 mA for ascending sensors and 17.38 mA (20.9% Vol) for Oxygen sensors. See the sensor data sheet for other potential values.

4.2. Zero Calibration

4.2.1. From Calibration Mode, Right Arrow to Zero Transmitter and select ENTER.

4.2.2. A notification screen will appear indicating to “Apply ZERO gas and press ENTER”.

WARNING: A Zero Calibration is as crucial as a Span Calibration. DO NOT zero a sensor in ambient atmosphere (except O2 sensors) as backgrounds of the target or cross-interferent gases will impair a valid Zero Calibration in either a positive or negative direction. Failure to use Sensidyne Zero Calibration Gas Standards during the Zero Calibration may result in property damage, severe personal injury, or death during actual gas release events due to the impaired Zero Calibration.

NOTE: During zero calibration, the 4–20 mA signal is locked at 4 mA for ascending sensors. Oxygen sensors cannot be zero calibrated.

- 4.2.3. Apply the zero gas and the Gas Monitor will begin calibration automatically. If the calibration gas does not begin automatically, check the tubing connection and that the cylinder regulator is on.
- 4.2.4. Once the Zero Calibration is completed successfully, the following screen will be displayed.

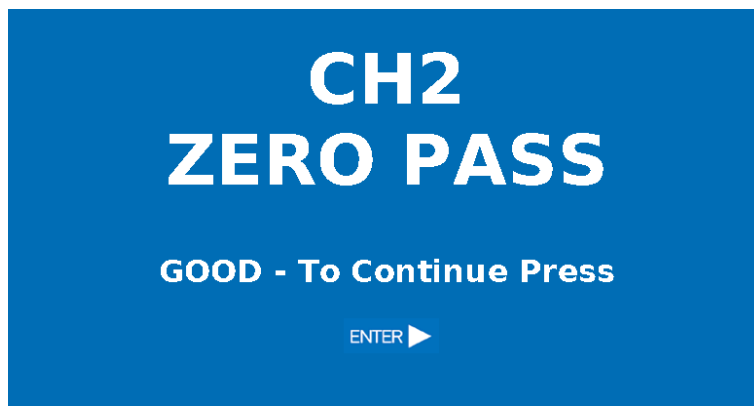

NOTE: If ENTER is not selected, the Gas Monitor reverts to the Previous Display after 10 minutes, and ultimately back to Normal Operations, which re-activates the 4 – 20 mA output.

- 4.2.5. If Zero Calibration fails, the following screen is displayed. Ensure adequate time has passed for sensor stabilization, and that the calibration equipment is properly connected with proper flow before reattempting the Zero Calibration.



NOTE: If Zero Calibration continues to fail, refer to the Troubleshooting Section in this manual. If unresolved, contact Sensidyne Customer Support for assistance.

4.3. Span Calibration

Important information concerning sensor function is stored in the sensor memory each time it is calibrated and during normal operation. Sensor data includes zero and span calibration parameters, as well as the temperature compensation characteristics for the sensor. This gives the SensAlert Flex sensors a special capability to be calibrated in a bench or shop location using one Gas Monitor, and then installing it in the field Gas Monitor without modification or recalibration.

NOTE: The Gas Monitor should be calibrated if the sensor assembly has been replaced with an uncalibrated sensor or the Gas Monitor has been exposed to gas concentrations at alarm levels.

4.3.1. Sensor Adjustment

In the Calibration Mode submenu is Sensor Adjustment. It permits a K-Factor to be applied for combustible gas sensors. A K-Factor is used for combustible sensors when the target gas is different from the calibration gas (Methane or Propane). Refer to the sensor datasheet to select a K-Factor before calibrating any Catalytic Bead or Infrared Combustible Sensors for use with a combustible gas other than Methane or Propane.

- 4.3.1.1. To enter a K-Factor, from the Calibration Mode go to the Sensor Adjustment submenu and select ENTER. Common combustible gases are listed, which may be selected rather than the K-Factor value. If the combustible gas is not listed, select Custom K-Factor to enter the value from the specific sensor datasheet.

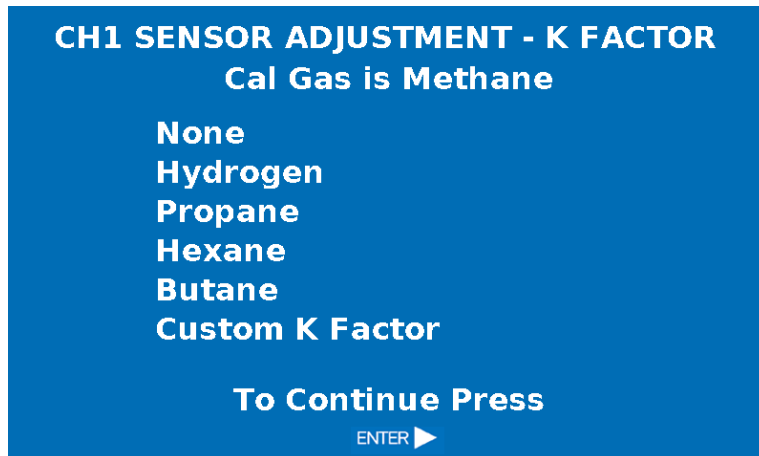

NOTE: There are no adjustments for Oxygen or Toxic sensors.

4.3.2. Set Cal Gas Conc. (Concentration)

Span Gas Calibration Standards list the concentration of the gas. Sensidyne recommends calibrating sensors (except O2 sensors) at 50% or half of the full range.

- 4.3.2.1. Before starting any Span Calibration, always confirm the Gas Monitor is configured for the calibration gas standard concentration. From the Calibration Mode, select Set Cal Gas Conc and enter the value of the calibration gas standard concentration.



4.3.3. Calibrate

This span calibration procedure applies to most sensors. However, some sensors have unique requirements. Refer to the specific sensor data sheet for the sensor to be used for a complete list of instructions.

NOTE: During calibration, the 4–20 mA signal is locked at 4 mA for ascending sensors and 17.38 mA (20.9% Vol) for Oxygen sensors. See the sensor data sheet for other potential values.

- 4.3.3.1. From Calibration Mode, Arrow to Calibrate and select ENTER.
- 4.3.3.2. A notification screen will appear indicating to “Apply gas and press ENTER”.

WARNING: Span Calibrations are crucial to Gas Monitor performance. Properly connected calibration gases utilizing the appropriate accessories is required. Failure to use Sensidyne Zero Calibration Gas Standards during the Span Calibration may result in property damage, severe personal injury, or death during actual gas release events due to the impaired Span Calibration.



- 4.3.3.3. Apply the span gas and the Gas Monitor will begin calibration automatically. If the calibration gas does not begin automatically, check the tubing connection and that the cylinder regulator is on.
- 4.3.3.4. Once the Span Calibration is completed successfully, the following screen will be displayed.



NOTE: If ENTER is not selected, the Gas Monitor reverts to the Previous Display after 10 minutes, and ultimately back to Normal Operations, which re-activates the 4 – 20 mA output.

- 4.3.3.5. If Span Calibration fails, the following screen is displayed. Ensure adequate time has passed for sensor stabilization, and that the calibration equipment is properly connected with proper flow before reattempting the Span Calibration.



NOTE: If Span Calibration continues to fail, refer to the Troubleshooting Section in this manual. If unresolved, contact Sensidyne Customer Support for assistance.

4.4. Test-on-Demand™ (ToD)

This section covers the following **Test-On-Demand™ (ToD) Mode Adjustment** submenu functions.

- Enable and disable the automatic testing mode
- Set the date & time for testing
- Set the number of days between tests
- Set the cell intensity
- Designate output & fault indicators

4.4.1. From the System screen, select the Channel for ToD to be configured.

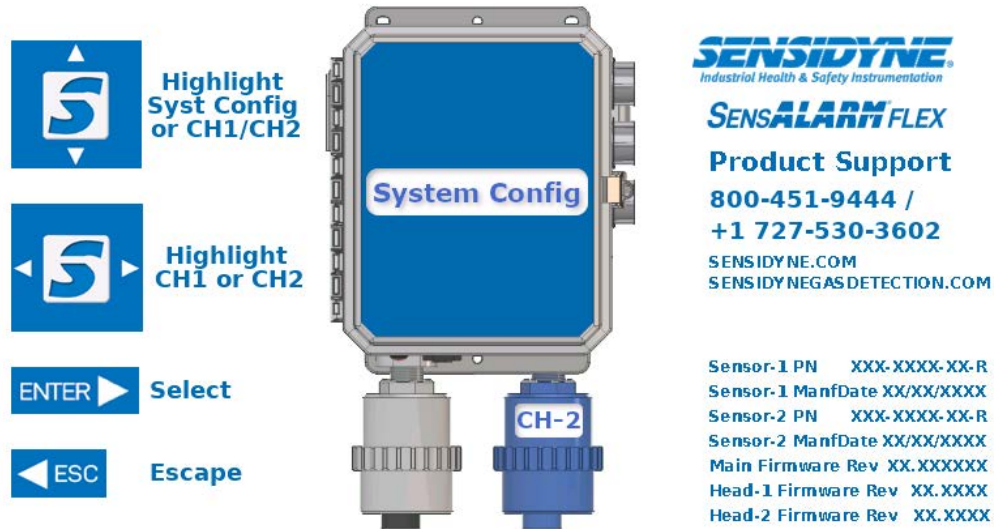

4.4.2. Arrow to TOD Mode and the following submenus will appear:

- Auto Mode
- Test Day / Time
- Days Between Tests
- Cell Intensity
- Output Indicators

4.4.3. **Auto Mode Enable** is a convenient way to automatically perform a Test-On-Demand at regular intervals (e.g., every 7 days).

NOTE: When Test-On-Demand is performed automatically and the test fails because gas is present, system message will appear on the Normal Operation Mode Display and fault output (if enabled) will appear.

4.4.3.1. From the TOD Mode menu, Arrow to the Auto Mode submenu and select ENTER.

4.4.3.2. Use the UP / DOWN arrows to Enable / Disable Test-On-Demand Auto Mode, and select ENTER.

4.4.4. **Test Day / Time** selects the date and time of for Test-On-Demand to be initiated while in Auto Mode.

4.4.4.1. From the TOD Mode menu, Arrow to the Test Day / Time submenu and select ENTER.

4.4.4.2. Select the date and time to initiate Test-On-Demand. The frequency of future Test-On-Demand schedules will be established in additional steps.

4.4.5. **Days Between Tests** establishes the frequency of Test-On-Demand bump tests starting from the Test Day / Time selection.

4.4.5.1. From the TOD Mode menu, Arrow to the Days Between Tests submenu and select ENTER.

- 4.4.5.2. Use the UP / DOWN arrows to select the number of days starting from the Days Between Tests selection and subsequent future tests. Test-On-Demand will continue to run bump tests at these selected frequency, and at the time entered during the Test Day / Time selection.

- 4.4.6. **Cell Intensity** establishes the magnitude of Test-On-Demand, and changes the intensity of the gas produced by the ToD cell. Higher Intensities create stronger concentrations of gas. The factory setting is 50% and is normally adequate for most installations. However, Environmental factors such as wind or humidity may interfere with the sensors ability to detect the gas. Increasing the Intensity will overcome most of these effects.
 - 4.4.6.1. From the TOD Mode menu, Arrow to the cell Intensity submenu and select ENTER.
 - 4.4.6.2. Use the UP / Down arrows to increase or decrease the cell intensity. Once set, select ENTER to save the value.

- 4.4.7. **Output Indicators** permit the user to either hold the 4 to 20mA output or allow the 4 to 20mA output to follow the sensor output during a Test-On-Demand.
 - 4.4.7.1. From the TOD Mode menu, Arrow to the Output Indicators submenu, and select ENTER.
 - 4.4.7.2. Use the Arrow keys to select None to hold the 4 to 20mA output during ToD, or 4-20 Current Loop to follow the sensor out during ToD. Once set, select ENTER to save.

WARNING: The Gas Monitor will not provide an alarm or output to actual target gas exposures during ToD events if None is selected as an output indicator.

5. ALARMS, FAULTS AND RELAYS

SensAlarm Flex allows for the configuration of alarms, faults and relay outputs. There are four (4) unique alarms and ten (10) faults per Sensor Interface Channel. The Gas Monitor also includes four (4) standard SPDT relays and an additional four (4) optionally. Relays can be set to function with alarms and / or faults.

The four (4) **Alarm** levels with each Sensor Interface Channel are:

- **Alarm 1:** Traditionally utilized as a low alarm.
- **Alarm 2:** Traditionally utilized as a high alarm.
- **Alarm 3:** Traditionally utilized as a high-high alarm.
- **TWA Alarm:** A Time **W**eighted **A**verage (TWA) alarm. Traditionally over an 8-hour timeframe.

The ten (10) **Fault** levels with each Sensor Interface Channel are:

- **Head Fail:** Indicates a loss of communication with a Sensor Interface.
- **Missing Sensor:** Indicates loss of communication to a sensor or a sensor is not installed.
- **Sensor Fail:** Indicates an abnormal sensor output.
- **Sensor End Of Life:** Indicates the potential of an end of life of a sensor.
- **Output Current Track:** Indicates an abnormal output current.
- **Calibration Mode:** Indicates the performance of sensor calibration, and holding of the Gas Monitor output.
- **Calibration Due:** Indicates the sensor calibration per channel is due.
- **Maintenance Mode:** Indicates the holding of the Gas Monitor output.
- **ToD Fail:** Indicates that a Test-on-Demand failed to respond with the gas sensor.
- **ToD End of Life:** Indicates the end of a typical ToD life-span.

5.1. Alarms

This section covers the following **Alarm Configuration** submenu functions.

- 5.1.1. From the System screen, use the Arrows to highlight System Configuration, and select ENTER.

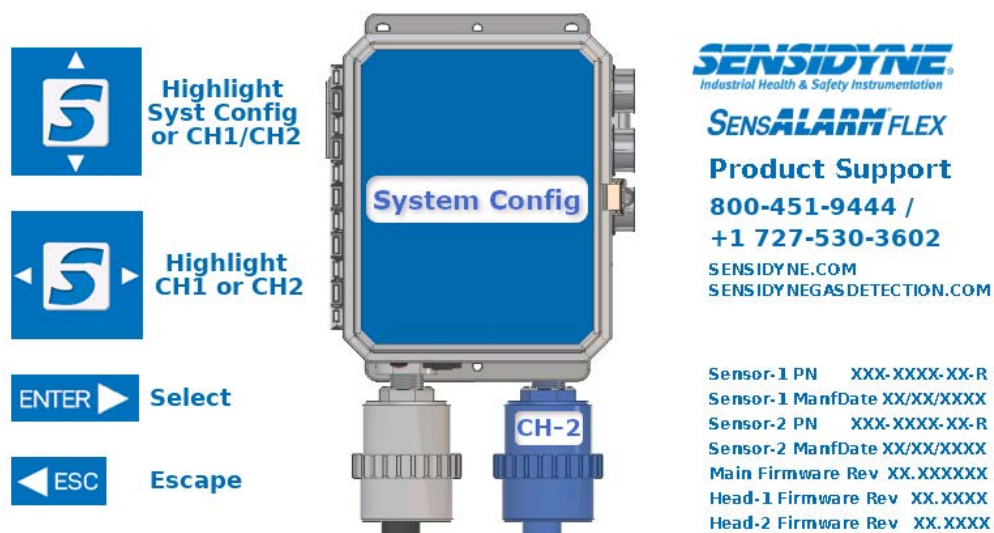

5.1.2. Arrow to System Configuration and the below submenus will appear.

- Fault Current
- Relay Configuration
- Strobe Configuration
- Alarm Configuration
- Fault Configuration
- Relay Matrix
- 4 to 20mA Adjustment
- Communication Setup
- Set Transmitter Tag

5.1.3. Arrow to Alarm Configuration, and select ENTER.

5.1.4. The Alarm Configuration screen allows relays to be set with specific alarms, the enabling / disabling of alarms. Whether the alarm thresholds are from ascending or descending sensor values, the alarm threshold, and a release offset. The first screen displays Alarms 1 and 2. Selecting “Next Page” reveals Alarm 3 and the TWA Alarm, ESC returns the user to the previous screen. Note that the Alarms are unique to Channels 1 and 2.

	CH-1	CH-2
Next Page	Alarm Configuration	
Alarm 1	Relays Assigned 12345678 Enabled Ascending Setpoint XX.XXppm Release Offset XX.XX%VOL	Relays Assigned 12345678 Enabled Ascending Setpoint XX.XXppm Release Offset XX.XX%VOL
Alarm 2	Relays Assigned 12345678 Enabled Ascending Setpoint XX.XXppm Release Offset XX.XX%VOL	Relays Assigned 12345678 Enabled Ascending Setpoint XX.XXppm Release Offset XX.XX%VOL

	CH-1	CH-2
	Alarm Configuration 2	
Alarm 3	Relays Assigned 12345678 Enabled Ascending Setpoint XX.XXppm Release Offset XX.XX%VOL	Relays Assigned 12345678 Enabled Ascending Setpoint XX.XXppm Release Offset XX.XX%VOL
TWA Alarm	Relays Assigned 12345678 Enabled Ascending Setpoint XX.XXppm Avg Time XX.XX %VOL	Relays Assigned 12345678 Enabled Ascending Setpoint XX.XXppm Avg Time XX.XX %VOL

- 5.1.4.1. Relays Assigned – By Arrowing to this field and selecting ENTER, the user can set any relay to an Alarm Level for each Channel. Note that relays can also be configured to any alarm or fault in the Relay Matrix submenu, which gives the user visibility of all the assigned relays.
- 5.1.4.2. Enabled / Disabled - By Arrowing to this field and selecting ENTER, the user can Enable or Disable any Alarm Level for each Channel. Note that Disabling an Alarm does not change any of the pre-established configurations, it only prevents those actions from occurring.
- 5.1.4.3. Ascending / Descending – By Arrowing to this field and selecting ENTER, the user can indicate if the Setpoint threshold is exceeded by either gas concentrations that increase or ascend, or gas concentrations that decrease or descend. An example of the need for a descending alarm is oxygen (O₂).
- 5.1.4.4. Setpoint - By Arrowing to this field and selecting ENTER, the user can establish the alarm threshold for the Alarm Level. Note that the value is not limited based on low, high, or high-high limits, but Alarms 1, 2 and 3 can be set to any threshold level. Sensidyne recommends using Alarms 1, 2 and 3 in a logical order to avoid integration confusion. Also note that the Setpoint is limited to the range of the installed sensor.
- 5.1.4.5. Release Offset - By Arrowing to this field and selecting ENTER, the user can enter a value that the concentration must differ by before releasing Alarms 1, 2 and 3 only.
- 5.1.4.6. Avg Time – By Arrowing to this field and selecting ENTER, the user can set the timeframe for averaging to be calculated. This setting is unique to the TWA Alarm only. The user can select from the below pre-established timeframes.
 - 15 minutes
 - 30 minutes
 - 1 hour
 - 2 hours
 - 4 hours
 - 8 hours (the traditional timeframe for TWA calculations)

5.2. Faults

This section covers the following **Fault Configuration** submenu functions.

- 5.2.1. From the System screen, use the Arrows to highlight System Configuration, and select ENTER.

The diagram shows a Sensidyne SensAlarm Flex device with a blue screen displaying 'System Config'. To the left of the device are four navigation instructions:

- Highlight Syst Config or CH1/CH2
- Highlight CH1 or CH2
- Select
- Escape

To the right of the device is the Sensidyne logo and product information:

SENSIDYNE
Industrial Health & Safety Instrumentation

SENSALARM FLEX

Product Support
800-451-9444 /
+1 727-530-3602
SENSIDYNE.COM
SENSIDYNEGASDETECTION.COM

Below the product information is a list of sensor and firmware details:

```
Sensor-1 PN   XXX-XXXX-XX-R
Sensor-1 ManfDate XX/XX/XXXX
Sensor-2 PN   XXX-XXXX-XX-R
Sensor-2 ManfDate XX/XX/XXXX
Main Firmware Rev XX.XXXXXX
Head-1 Firmware Rev XX.XXXX
Head-2 Firmware Rev XX.XXXX
```

5.2.2. Arrow to System Configuration and the below submenus will appear.

- Fault Current
- Relay Configuration
- Strobe Configuration
- Alarm Configuration
- Fault Configuration
- Relay Matrix
- 4 to 20mA Adjustment
- Communication Setup
- Set Transmitter Tag

5.2.3. Arrow to Fault Configuration, and select ENTER.

The Fault Configuration screen allows relays to be set with specific faults, the enabling / disabling of faults, the 4 to 20mA output associated with a fault, and for certain faults any delay times for the 4 to 20mA output. The ten (10) faults are presented on three (3) separate screens that the user can navigate to by selecting “Next Page”, ESC will return the user to the previous screen. Note that the Faults are unique to Channels 1 and 2.

Next Page			Fault Configuration	
	CH-1		CH-2	
Head Fail	Relays Assigned 12345678 Enabled Fault Current XX.XX		Relays Assigned 12345678 Enabled Fault Current XX.XX	
Missing Sensor	Relays Assigned 12345678 Enabled Fault Current XX.XX		Relays Assigned 12345678 Enabled Fault Current XX.XX	
Sensor Fail	Relays Assigned 12345678 Enabled Fault Current XX.XX		Relays Assigned 12345678 Enabled Fault Current XX.XX	
Sensor EOL	Relays Assigned 12345678 Enabled Fault Current XX.XX Current Delay XXX		Relays Assigned 12345678 Enabled Fault Current XX.XX Current Delay XXX	

Next Page			Fault Configuration	
	CH-1		CH-2	
Output Current Track	Relays Assigned 12345678 Enabled Fault Current XX.XX Current Delay XXX		Relays Assigned 12345678 Enabled Fault Current XX.XX Current Delay XXX	
Calibration Mode	Relays Assigned 12345678 Enabled Fault Current XX.XX		Relays Assigned 12345678 Enabled Fault Current XX.XX	
Maintenance Mode	Relays Assigned 12345678 Enabled Fault Current XX.XX		Relays Assigned 12345678 Enabled Fault Current XX.XX	

Fault Configuration		
	CH-1	CH-2
TOD Fail	Relays Assigned 12345678	Relays Assigned 12345678
	Enabled	Enabled
	Fault Current XX.XX	Fault Current XX.XX
	Current Delay XXX	Current Delay XXX
TOD EOL	Relays Assigned 12345678	Relays Assigned 12345678
	Enabled	Enabled
	Fault Current XX.XX	Fault Current XX.XX
	Current Delay XXX	Current Delay XXX
Calibration Due	Relays Assigned 12345678	Relays Assigned 12345678
	Enabled	Enabled
	Fault Current XX.XX	Fault Current XX.XX
	Current Delay XXX	Current Delay XXX
	Days Between XXX	Days Between XXX

- 5.2.3.1. Relays Assigned – By Arrowing to this field and selecting ENTER, the user can set any relay to a specific Fault for each Channel. Note that relays can also be configured to any alarm or fault in the Relay Matrix submenu, which gives the user visibility of all the assigned relays.
- 5.2.3.2. Enabled / Disabled - By Arrowing to this field and selecting ENTER, the user can Enable or Disable any specific Fault for each Channel. Note that Disabling a Fault does not change any of the pre-established configurations, it only prevents those actions from occurring.
- 5.2.3.3. Fault Current – By Arrowing to this field and selecting ENTER, the user can establish a unique 4 to 20mA output for each Fault per Channel. The 4mA output represents zero concentration (except O₂, which the normal output is 17.38mA). Traditionally, users will use the levels below 4mA to indicate certain Faults. By setting a specific Fault per Channel to a unique mA signal, users can identify individual Faults per Channel remotely when configured in a facility DCS or Control System.
- 5.2.3.4. Current Delay - By Arrowing to this field and selecting ENTER, the user can delay the specific mA signal associated with specific Faults per Channel. The delay can be set from 1 to 240 seconds to prevent the potential for nuisance Faults. Also note that the Current Delay is only available for certain Faults, typically accepted as low priority events. High priority Faults cannot be delayed.

NOTE: Maximum delay time for Head Fail condition is 15 seconds..

- 5.2.3.5. Days Between – By arrowing to this field and selecting ENTER, the user can set the specific calibration due frequency associated with the Calibration Due Fault per Channel. The selectable Days Between are 30, 60, 90 and 180 days depending on the sensor type and stage of sensor installation. For additional information regarding specific calibration requirements for individual sensors, reference the Sensidyne Sensor Field Calibration Policy, which can be obtained by request at info@sensidyne.com or by factory phone call at (727) 530-3602.

5.3. Relays

SensAlarm Flex includes four (4) standard SPDT 5A relays to provide the user with local functional controls. An additional four (4) relays can be included optionally. Relays are configured by default as de-energized and non-latching, but can be configured independently per application requirements, and wired in either Normally Open (NO) or Normally Closed (NC) states. Relays are numbered from top to bottom, with one (1) through four (4) on the left relay board, and if installed five (5) through eight (8) on the right relay board. Each relay has an independent LED that lights when the relay is energized. Note that if the relay is configured normally energized, the LED will turn off during an activation, and the state opposite of the wiring position.

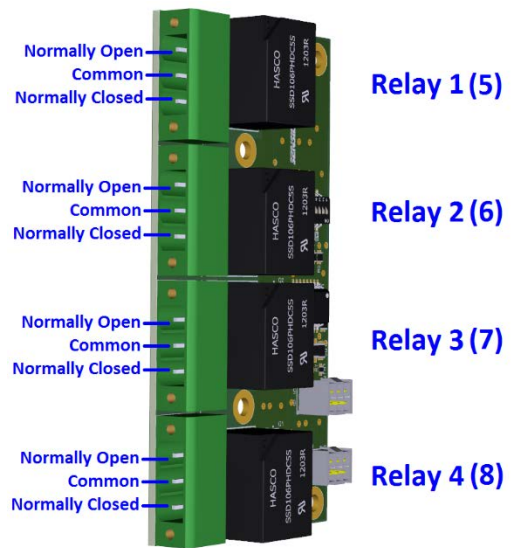
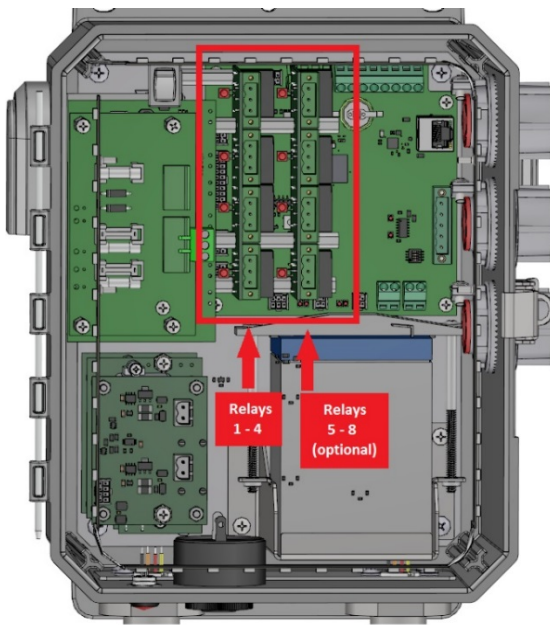
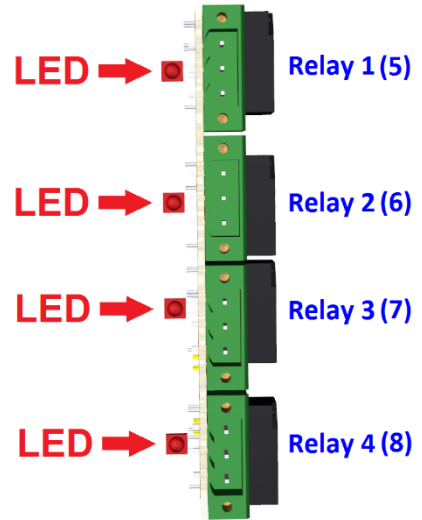

This section covers the following **Relay Configuration** submenu functions.

- 5.3.1. From the System screen, use the Arrows to highlight System Configuration, and select ENTER.

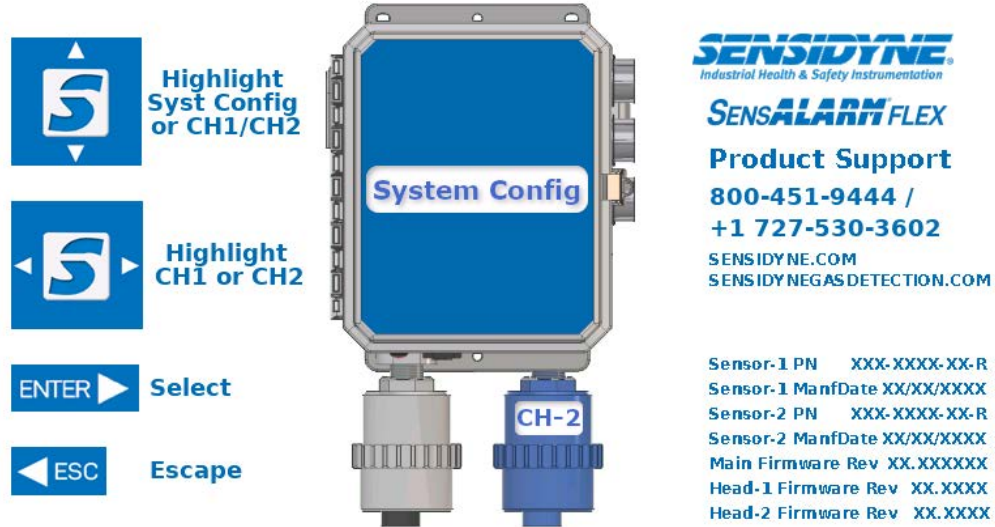

- 5.3.2. Arrow to System Configuration and the below submenus will appear.

- Fault Current
- Relay Configuration
- Strobe Configuration
- Alarm Configuration
- Fault Configuration
- Relay Matrix
- 4 to 20mA Adjustment
- Communication Setup
- Set Transmitter Tag

- 5.3.3. Arrow to Relay Configuration, and select ENTER.

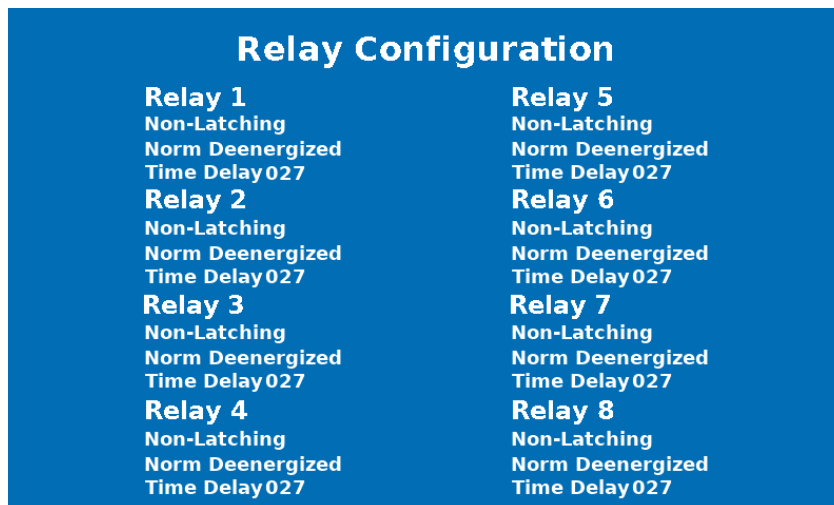

- 5.3.3.1. Non-Latching / Latching - By Arrowing to this field and selecting ENTER, the user can configure individual relays to either Latch with an Alarm or Fault, which requires the relay to be reset with the external reset pushbutton even if the Alarm or Fault condition has been cleared, or Non-Latch where the relay will automatically reset when the Alarm or Fault condition clears.
- 5.3.3.2. Normally De- Energized / Energized - By Arrowing to this field and selecting ENTER, the user can set relays to be either Fail-Safe (Energized) or Fail-Secure (De-Energized). An example of Fail-Safe is when a specific function is desired to occur with a power loss. Fail-Secure ensures that actions do not occur when a power loss occurs.
- 5.3.3.3. Time Delay - By Arrowing to this field and selecting ENTER, the user can set a Time Delay before the relay changes state due to an Alarm or Fault it is configured to. The delay can be set from 1 to 240 seconds where application requirements may be needed.
- 5.3.4. SensAlarm Flex offers a single location in **the Relay Matrix** to view what relays have been assigned to Alarms and / or Faults to give users and integrators a high-level view of the assignments, and make changes.
 - 5.3.4.1. From the System Configuration menu, Arrow to Relay Matrix, and select ENTER.

CH-2 Relay Matrix								
CH-2	Relays							
	1	2	3	4	5	6	7	8
Alarm 1	<input type="checkbox"/>	<input type="checkbox"/>	<input type="checkbox"/>	<input type="checkbox"/>	<input type="checkbox"/>	<input type="checkbox"/>	<input type="checkbox"/>	<input type="checkbox"/>
Alarm 2	<input type="checkbox"/>	<input type="checkbox"/>	<input type="checkbox"/>	<input type="checkbox"/>	<input type="checkbox"/>	<input type="checkbox"/>	<input type="checkbox"/>	<input type="checkbox"/>
Alarm 3	<input type="checkbox"/>	<input type="checkbox"/>	<input type="checkbox"/>	<input type="checkbox"/>	<input type="checkbox"/>	<input type="checkbox"/>	<input type="checkbox"/>	<input type="checkbox"/>
TWA Alarm	<input type="checkbox"/>	<input type="checkbox"/>	<input type="checkbox"/>	<input type="checkbox"/>	<input type="checkbox"/>	<input type="checkbox"/>	<input type="checkbox"/>	<input type="checkbox"/>
Head Fail	<input type="checkbox"/>	<input type="checkbox"/>	<input type="checkbox"/>	<input type="checkbox"/>	<input type="checkbox"/>	<input type="checkbox"/>	<input type="checkbox"/>	<input type="checkbox"/>
Missing Sensor	<input type="checkbox"/>	<input type="checkbox"/>	<input type="checkbox"/>	<input type="checkbox"/>	<input type="checkbox"/>	<input type="checkbox"/>	<input type="checkbox"/>	<input type="checkbox"/>
Sensor Fail	<input type="checkbox"/>	<input type="checkbox"/>	<input type="checkbox"/>	<input type="checkbox"/>	<input type="checkbox"/>	<input type="checkbox"/>	<input type="checkbox"/>	<input type="checkbox"/>
Sensor EOL	<input type="checkbox"/>	<input type="checkbox"/>	<input type="checkbox"/>	<input type="checkbox"/>	<input type="checkbox"/>	<input type="checkbox"/>	<input type="checkbox"/>	<input type="checkbox"/>
Output Current Track	<input type="checkbox"/>	<input type="checkbox"/>	<input type="checkbox"/>	<input type="checkbox"/>	<input type="checkbox"/>	<input type="checkbox"/>	<input type="checkbox"/>	<input type="checkbox"/>
Calibration Mode	<input type="checkbox"/>	<input type="checkbox"/>	<input type="checkbox"/>	<input type="checkbox"/>	<input type="checkbox"/>	<input type="checkbox"/>	<input type="checkbox"/>	<input type="checkbox"/>
Maintenance Mode	<input type="checkbox"/>	<input type="checkbox"/>	<input type="checkbox"/>	<input type="checkbox"/>	<input type="checkbox"/>	<input type="checkbox"/>	<input type="checkbox"/>	<input type="checkbox"/>
Calibration Due	<input type="checkbox"/>	<input type="checkbox"/>	<input type="checkbox"/>	<input type="checkbox"/>	<input type="checkbox"/>	<input type="checkbox"/>	<input type="checkbox"/>	<input type="checkbox"/>

- 5.3.4.2. By Arrowing to specific Relays, Alarms and / or Faults, users can assign or un-assign Relays associated with these events. Note that making a change here does override relay selections during specific Alarm or Fault Configurations, but only for the relay assignments. Other Alarm and Fault Configurations will remain unchanged.

5.4. Strobes

SensAlarm Flex offers a standard integrated Front Panel LED Strobe that can provide Green, Red, Yellow and Blue notifications. Optionally a LED Light Stack can be added to the Gas Monitor too when 360° visibility is required. The Front Panel and Light Stack Strobes work in unison to ensure consistency in the assigned purpose of each color. The Strobes can be configured as Flashing or Non-Flashing to ensure nearby workers recognize either the conspicuous or non-conspicuous nature of the assigned Strobe color (except in Battery Back-up where strobes only Flash to extend battery life).



This section covers the following **Strobe Configuration** submenu functions.

- 5.4.1. From the System screen, use the Arrows to highlight System Configuration, and select ENTER.

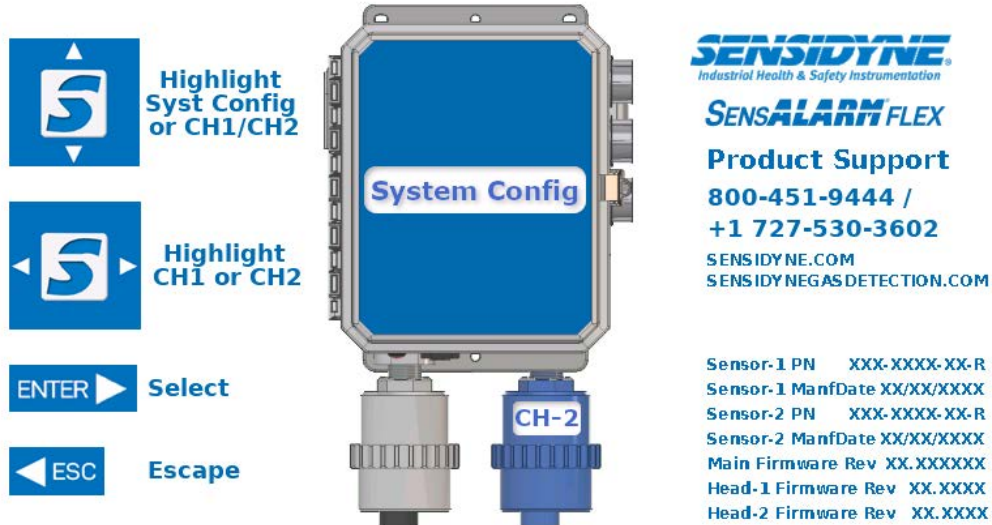

- 5.4.2. Arrow to System Configuration and the below submenus will appear.

- Fault Current
- Relay Configuration
- Strobe Configuration
- Alarm Configuration
- Fault Configuration
- Relay Matrix
- 4 to 20mA Adjustment
- Communication Setup
- Set Transmitter Tag

- 5.4.3. Arrow to Strobe Configuration, and select ENTER.

- 5.4.4. In the Strobe Configuration Screen, users can Arrow to specific Alarm or Fault conditions, and associate them with specific colors by selecting ENTER. Strobes can also be configured as Flashing or Non-Flashing. Note that Green is the None selection, and that by selecting None nearby workers will not be notified of the event. Traditionally Green is recognized as a Normal Condition, indicating that the Gas Monitor is functioning. Red typically represents a High or High-High Alarm event. Yellow normally represents a Low Alarm, and Blue is used to indicate a Fault Condition. These indications should be associated with personnel training to ensure an appropriate response to the related condition.

- 5.4.5. Strobe intensity can be modified from bright to dim. From System Configuration, Arrow to Setup, then LED Brightness and select ENTER. Each color can be adjusted from 100% intensity to 10%.

6. CONFIGURATION

6.1. 4 to 20mA Adjustment

Due to the resistive differences in 4 to 20mA infrastructures from wire lengths, wire junctions, and control system circuits, the Gas Monitor 4 to 20mA output should be checked to ensure that the control system or DCS is receiving an accurate signal representation, and adjusted if necessary. This will ensure that the DCS or remote SCADA system accurately presents the SensAlarm Flex gas concentration, and Fault signal representations.

This section covers the following **4 to 20mA Adjustment** submenu functions.

- 6.1.1. From the System screen, use the Arrows to highlight System Configuration, and select ENTER.



- 6.1.2. Arrow to System Configuration and the below submenus will appear.

- Fault Current
- Relay Configuration
- Strobe Configuration
- Alarm Configuration
- Fault Configuration
- Relay Matrix
- 4 to 20mA Adjustment
- Communication Setup
- Set Transmitter Tag

- 6.1.3. Arrow to 4 to 20mA Adjustment, and select ENTER.

In the 4 to 20mA Adjustment Screen, users can Arrow to four (4) specific analog output values, and force the Gas Monitor to the value by selecting ENTER.

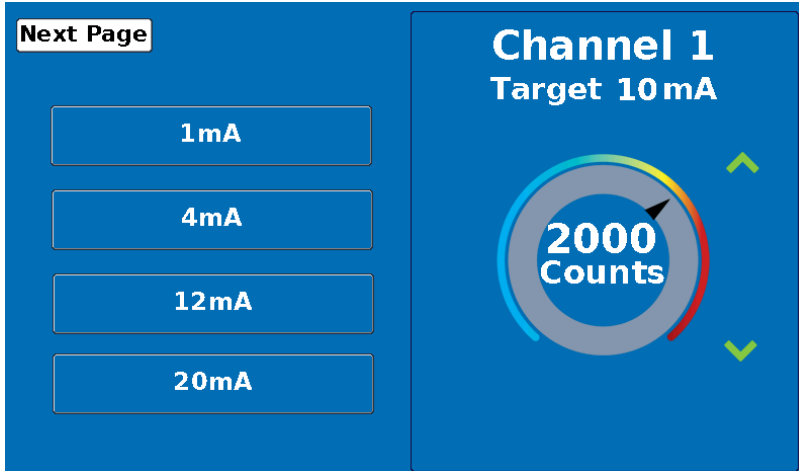

6.1.4. A multimeter will be required to monitor the 4 to 20mA output. To connect the multimeter, set the meter to millivolts (mV), and connect the probes to the 4 to 20mA PCA located in the bottom left of the Gas Monitor enclosure, and to the Sensor Interface Channel to be checked and adjusted.

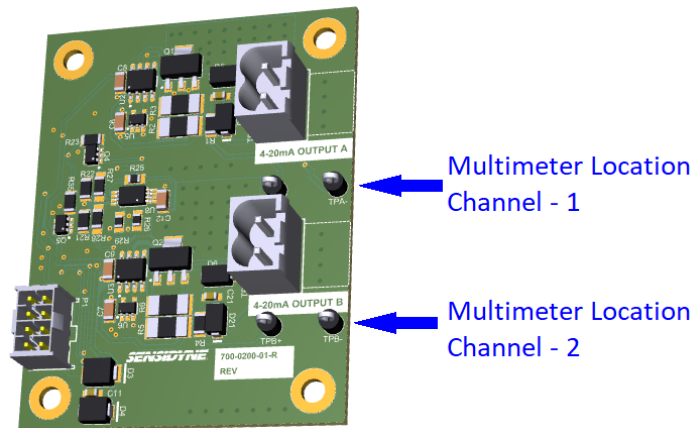

6.1.5. The multimeter will display in millivolts (mV) the following values for each of the below milliamp (mA) output. This reading is a true representation of the circuit and what the control system is reading, and what the SCADA will base values on. Confirmation at the DCS is unnecessary, but may be preferred. This method is provided to allow a technician to perform the verifications locally, and to make the process more efficient by limiting the process to a single technician and to save the time moving between the Gas Monitor and DCS.

- 1mA Output = 10mV multimeter display
- 4mA Output = 40mV multimeter display
- 12mA Output = 120mV multimeter display
- 20mA Output = 200mV multimeter display

6.1.6. Sensidyne recommends verifying all four (4) mA values, and adjusting them as needed. While monitoring the multimeter display for the selected Sensor Interface Channel, Arrow to the mA value to be confirmed and select ENTER.

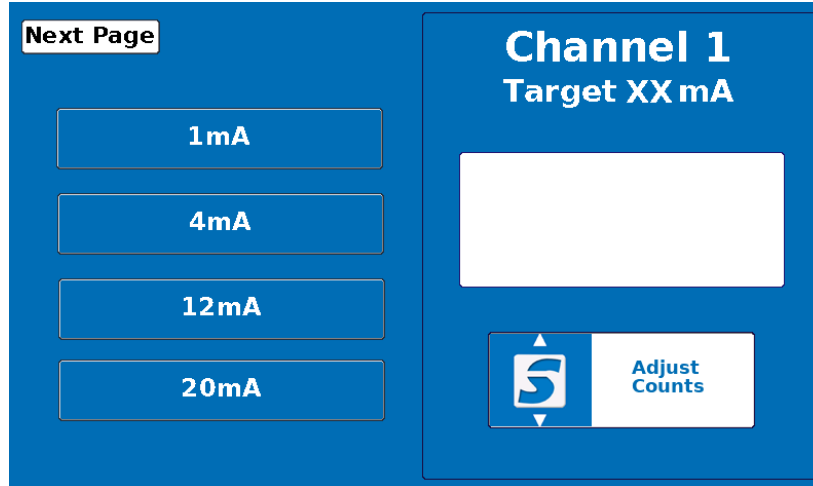

6.1.7. Once the 4 to 20mA output has been forced to the selected value, check the multimeter display. If adjustment is needed, use the Up / Down Arrows until the multimeter display indicates the proper value, and select ENTER to save the setting.

- 1mA Output = 10mV multimeter display
- 4mA Output = 40mV multimeter display
- 12mA Output = 120mV multimeter display
- 20mA Output = 200mV multimeter display

NOTE: The Gas Monitor must be terminated to a DCS with a load resistor between 100 and 500 ohms for the multimeter to display the millivolt (mV) representation of the milliamp (mA) output.

6.1.8. Repeat the procedure for the remaining mA outputs, selecting ENTER to save the adjustments for each once completed. NEXT PAGE will take the user to the Channel 2 Sensor Interface if included, which should be confirmed too.

NOTE: The “Counts” can be noted as a rough adjustment required for the other Sensor Interface Channel or additional Gas Monitors. The Counts values for each mA output can be used to quickly adjust other Sensor Interface Channels, but the multimeter mV displayed value should be confirmed for each and fine-tuned accordingly.

6.2. Communication Setup

SensAlarm Flex a standard 4 to 20mA output per Sensor Interface Channel that is located in the bottom left hand side of the enclosure. CH-1 represents the Left Sensor Interface, and CH-2 the right. CH-2 only functions when SensAlarm Flex is configured with the optional second Sensor Interface. Also included is both Modbus TCP and RTU (RS-485) as standard Gas Monitor inclusions. Both are easily accessible and are located on the right of the Main PCA. Modbus TCP accepts a standard RJ-45 Ethernet cable. Modbus RTU can be wired in half duplex (2-wire) or full duplex (4-wire).

This section covers the following **Communication Setup** submenu functions.

6.2.1. From the System screen, use the Arrows to highlight System Configuration, and select ENTER.

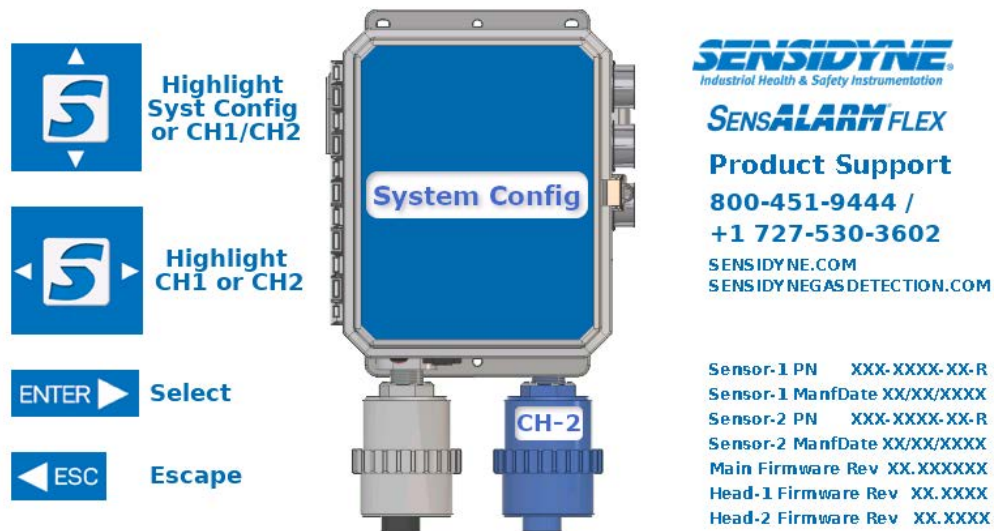

6.2.2. Arrow to System Configuration and the below submenus will appear.

- Fault Current
- Relay Configuration
- Strobe Configuration
- Alarm Configuration
- Fault Configuration
- Relay Matrix
- 4 to 20mA Adjustment
- Communication Setup
- Set Transmitter Tag

6.2.3. Arrow to Communication Setup, and select ENTER.

In the Communication Setup Screen, users can Arrow to the communication protocol to be configured in the Gas Monitor by selecting ENTER.



6.2.4. Modbus RS-485 RTU communication setup establishes the requirements unique to the control system for the Gas Monitor to interface with. The values include the Modbus address, baud rate, and if parity or stop bits are required. Only a qualified system integrator should configure the RS-485 RTU parameters.

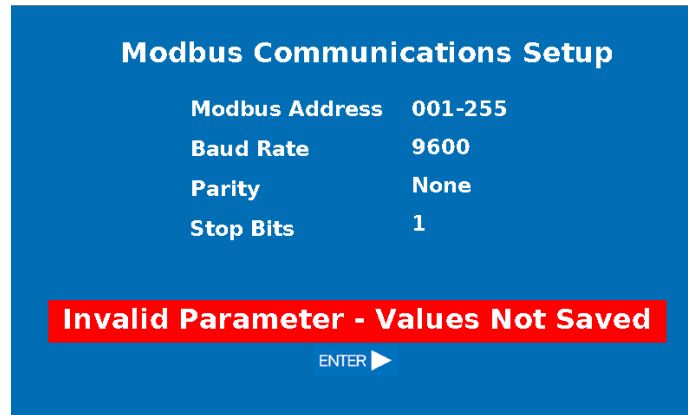

6.2.4.1. The RS-485 RTU Modbus specifications are:

- Baud Rate: 9600, 19200, 38400
- Parity: None, Even, Odd
- Start Bit: 1
- Data Bits: 8
- Stop Bit: 1 for Parity, 1 or 2 for No Parity

6.2.4.2. Wire Recommendations

- 20-24 AWG Twisted Pair, Overall Shielded
 - 2 Wire - Single Pair
 - 4 Wire - Two Pair
- Belden 9501, 9502, 8451, 8761, 1419A
- Alpha Wire 5471C, 5472C

6.2.5. The **Modbus TCP** configuration allows the system integrator to set the unique IP address required for system communication.



6.2.6. Modbus Register Types and Locations

6.2.6.1. Coils Head 1

00001	Start Zeroing Sensor
00004	Start Sensor Calibration
00007	Start Automatic TOD Test
00010	Stop Sensor Calibration
00021	Enable Alarm 1
00022	Enable Alarm 2
00023	Enable Alarm 3
00024	Enable Alarm 4 (TWA)
00032	TOD Fail Enable
00041	Head Fail Fault Enable
00042	Sensor Missing Fault Enable
00043	Sensor Fail Fault Enable
00044	Sensor End of Life Fault Enable
00045	TOD End of Life Enable
00046	Loop Current Out of Tolerance Fault Enable
00047	Calibration Mode Fault Enable
00048	Maintenance Mode Fault Enable
00049	Calibration Due Fault Enable

6.2.6.2. Coils Head 2

00301	Start Zeroing Sensor
00304	Start Sensor Calibration
00307	Start Automatic TOD Test
00310	Stop Sensor Calibration
00321	Enable Alarm 1
00322	Enable Alarm 2
00323	Enable Alarm 3
00324	Enable Alarm 4 (TWA)
00332	TOD Fail Enable
00341	Head Fail Fault Enable
00342	Sensor Missing Fault Enable
00343	Sensor Fail Fault Enable
00344	Sensor End of Life Fault Enable
00345	TOD End of Life Enable
00346	Loop Current Out of Tolerance Fault Enable
00347	Calibration Mode Fault Enable
00348	Maintenance Mode Fault Enable
00349	Calibration Due Fault Enable

6.2.6.3. Coils System

00617	Clear Latched Relays
00625	Relay 1 Latch Enable
00626	Relay 2 Latch Enable
00627	Relay 3 Latch Enable
00628	Relay 4 Latch Enable
00629	Relay 5 Latch Enable
00630	Relay 6 Latch Enable
00631	Relay 7 Latch Enable
00632	Relay 8 Latch Enable

6.2.6.4. Discrete Inputs Head 1

10001	Zeroing Sensor Started
10002	Zeroing Sensor Good
10003	Zeroing Sensor Failed
10004	Calibration of Sensor Started
10005	Calibration of Sensor Good
10006	Calibration of Sensor Failed
10007	TOD Test Started
10008	TOD Test Good
10009	TOD Test Failed
10017	Alarm 1 Active
10018	Alarm 2 Active
10019	Alarm 3 Active
10020	Alarm 4 Active
10031	TOD Test Fail Active
10033	Missing Sensor Active
10034	Head Fail Active
10035	Sensor Fail Active
10036	Sensor End of Life Active
10037	TOD End of Life Active
10038	Loop Current Out of Tolerance
10039	Calibration Mode Fault Active
10040	Maintenance Mode Fault Active
10041	Calibration Due Fault Active

6.2.6.5. Discrete Inputs Head 2

10301	Zeroing Sensor Started
10302	Zeroing Sensor Good
10303	Zeroing Sensor Failed
10304	Calibration of Sensor Started
10305	Calibration of Sensor Good
10306	Calibration of Sensor Failed
10307	TOD Test Started
10308	TOD Test Good
10309	TOD Test Failed
10317	Alarm 1 Active
10318	Alarm 2 Active
10319	Alarm 3 Active
10320	Alarm 4 Active
10331	TOD Test Fail Active
10333	Missing Sensor Active
10334	Head Fail Active
10335	Sensor Fail Active
10336	Sensor End of Life Active
10337	TOD End of Life Active
10338	Loop Current Out of Tolerance
10339	Calibration Mode Fault Active
10340	Maintenance Mode Fault Active
10341	Calibration Due Fault Active

6.2.6.6. Input Registers Head 1

30031	Float	Gas Concentration (no suppression)
30033	Float	Full Scale Value

30035	Float	Loop Current
30037	Float	TWA Gas Concentration
30039	Float	Sensor Temperature Degrees C
30041	Float	Max Gas Concentration
30043	Long	Date/Time of Max Gas Concentration
30095	Long	Date/Time of Last Calibration
30097	Float	Last Calibration Gas Concentration
30099	Float	Minimum Sensor Temperature
30101	Long	Date/Time of Minimum Sensor Temperature
30103	Float	Maximum Sensor Temperature
30105	Long	Date/Time of Maximum Sensor Temperature
30111	Float	Calibration Pre Exposure Gas Concentration
30159	Int	8 bits Sensor Type High 8 bits Sensor Type Low
30160	Int	Display Units
30163	Int	8 bits Head Version High 8 bits Head Version Low
30164	Int	8bits Sensor Version High 8 bits Sensor Version Low
30179	Float	Peak TOD Test Value
30181	Long	Date/Time of Last TOD Test
30183	Int	12 Bit Representation of Current Loop, 4mA is a count of 800, 20mA is a count of 4000

Date/Time values are seconds from 12:00:00 AM March 1, 2000

6.2.6.7. Input Registers Head 2

30331	Float	Gas Concentration (no suppression)
30333	Float	Full Scale Value
30335	Float	Loop Current
30337	Float	TWA Gas Concentration
30339	Float	Sensor Temperature Degrees C
30341	Float	Max Gas Concentration
30343	Long	Date/Time of Max Gas Concentration
30395	Long	Date/Time of Last Calibration
30397	Float	Last Calibration Gas Concentration
30399	Float	Minimum Sensor Temperature
30401	Long	Date/Time of Minimum Sensor Temperature
30403	Float	Maximum Sensor Temperature
30405	Long	Date/Time of Maximum Sensor Temperature
30411	Float	Calibration Pre Exposure Gas Concentration
30459	Int	8 bits Sensor Type High 8 bits Sensor Type Low
30460	Int	Display Units
30463	Int	8 bits Head Version High 8 bits Head Version Low
30464	Int	8bits Sensor Version High 8 bits Sensor Version Low
30479	Float	Peak TOD Test Value
30481	Long	Date/Time of Last TOD Test
30483	Int	12 Bit Representation of Current Loop, 4mA is a count of 800, 20mA is a count of 4000

Date/Time values are seconds from 12:00:00 AM March 1, 2000

6.2.6.8. Input Registers System

30761	Int	8 bits Display Version High 8 bits Display Version Low
30762	Int	8 bits Modbus Register Map Version High 8 bits Modbus Register Map Version Low

6.2.6.9. Holding Registers Head 1

40031	Float	Gas Concentration (Read Only)
40033	Float	Full Scale Value (Read Only)
40035	Float	Loop Current (Read Only)
40037	Float	TWA Gas Concentration (Read Only)
40127	Float	Alarm 1 Setpoint
40129	Float	Alarm 2 Setpoint
40131	Float	Alarm 3 Setpoint
40133	Float	Alarm 4 (TWA) Setpoint
40183	Int	12 Bit Representation of Current Loop, 4mA is a count of 800, 20mA is a count of 4000 (Read Only)

6.2.6.10. Holding Registers Head 2

40331	Float	Gas Concentration (Read Only)
40333	Float	Full Scale Value (Read Only)
40335	Float	Loop Current (Read Only)
40337	Float	TWA Gas Concentration (Read Only)
40427	Float	Alarm 1 Setpoint
40429	Float	Alarm 2 Setpoint
40431	Float	Alarm 3 Setpoint
40433	Float	Alarm 4 (TWA) Setpoint
40483	Int	12 Bit Representation of Current Loop, 4mA is a count of 800, 20mA is a count of 4000 (Read Only)

6.3. Menu Structure

6.3.1. System Menu

 Highlight Syst Config or CH1/CH2

 Highlight CH1 or CH2

 Select

 Escape

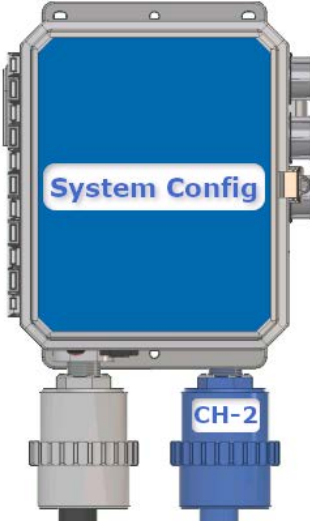

SENSIDYNE
Industrial Health & Safety Instrumentation

SENSALARM FLEX

Product Support
800-451-9444 /
+1 727-530-3602

SENSIDYNE.COM
SENSIDYNEGASDETECTION.COM

Sensor-1 PN XXX-XXXX-XX-R
Sensor-1 ManfDate XX/XX/XXXX
Sensor-2 PN XXX-XXXX-XX-R
Sensor-2 ManfDate XX/XX/XXXX
Main Firmware Rev XX.XXXXXX
Head-1 Firmware Rev XX.XXXX
Head-2 Firmware Rev XX.XXXX

6.3.1.1. System Configuration

6.3.1.2. Channel 1

6.3.1.3. Channel 2

6.3.2. SYSTEM CONFIGURATION (Submenus)

6.3.2.1. Maintenance Mode

- 6.3.2.1.1. Activate
- 6.3.2.1.2. Deactivate

6.3.2.2. Data Review

6.3.2.2.1. All Active Alarms

- 6.3.2.2.1.1. Alarm 1
- 6.3.2.2.1.2. Alarm 2
- 6.3.2.2.1.3. Alarm 3
- 6.3.2.2.1.4. TWA Alarm
- 6.3.2.2.1.5. Head Fail
- 6.3.2.2.1.6. Missing Sensor
- 6.3.2.2.1.7. Sensor Fail
- 6.3.2.2.1.8. Sensor EOL
- 6.3.2.2.1.9. Output Current Track
- 6.3.2.2.1.10. Calibration Mode
- 6.3.2.2.1.11. Maintenance Mode
- 6.3.2.2.1.12. TOD Fail
- 6.3.2.2.1.13. TOD EOL
- 6.3.2.2.1.14. Calibration Due

6.3.2.2.2. Fault Current

- 6.3.2.2.2.1. Head Fail (CH-1 (2) Current)
- 6.3.2.2.2.2. Missing Sensor (CH-1 (2) Current)
- 6.3.2.2.2.3. Sensor Fail (CH-1 (2) Current)
- 6.3.2.2.2.4. Sensor EOL (CH-1 (2) Current & Delay)
- 6.3.2.2.2.5. Output Current Track (CH-1 (2) Current & Delay)
- 6.3.2.2.2.6. Calibration Mode (CH-1 (2) Current)
- 6.3.2.2.2.7. Maintenance Mode (CH-1 (2) Current)
- 6.3.2.2.2.8. TOD Fail (CH-1 (2) Current & Delay)
- 6.3.2.2.2.9. TOD EOL (CH-1 (2) Current & Delay)
- 6.3.2.2.2.10. Calibration Due (CH-1 (2) Current & Delay)

6.3.2.2.3. Relay Configuration

- 6.3.2.2.3.1. Relay 1 – 8 (Non-Latching)
- 6.3.2.2.3.2. Relay 1 – 8 (Norm Deenergized)
- 6.3.2.2.3.3. Relay 1 – 8 (Time Delay)

6.3.2.2.4. Strobe Configuration

- 6.3.2.2.4.1. Alarm 1 (CH-1 (2) None, Red, Yellow, Blue)
- 6.3.2.2.4.2. Alarm 2 (CH-1 (2) None, Red, Yellow, Blue)
- 6.3.2.2.4.3. Alarm 3 (CH-1 (2) None, Red, Yellow, Blue)
- 6.3.2.2.4.4. TWA Alarm (CH-1 (2) None, Red, Yellow, Blue)
- 6.3.2.2.4.5. Head Fail (CH-1 (2) None, Red, Yellow, Blue)
- 6.3.2.2.4.6. Missing Sensor (CH-1 (2) None, Red, Yellow, Blue)

6.3.2.2.4.7.	Sensor Fail	(CH-1 (2) None, Red, Yellow, Blue)
6.3.2.2.4.8.	Sensor EOL	(CH-1 (2) None, Red, Yellow, Blue)
6.3.2.2.4.9.	Output Current Track	(CH-1 (2) None, Red, Yellow, Blue)
6.3.2.2.4.10.	Calibration Mode	(CH-1 (2) None, Red, Yellow, Blue)
6.3.2.2.4.11.	Maintenance Mode	(CH-1 (2) None, Red, Yellow, Blue)
6.3.2.2.4.12.	TOD Fail	(CH-1 (2) None, Red, Yellow, Blue)
6.3.2.2.4.13.	TOD EOL	(CH-1 (2) None, Red, Yellow, Blue)
6.3.2.2.4.14.	Calibration Due	(CH-1 (2) None, Red, Yellow, Blue)

6.3.2.2.5. Alarm Configuration

6.3.2.2.5.1. Alarm 1

6.3.2.2.5.1.1.	Relays Assigned (1 – 8)
6.3.2.2.5.1.2.	Enabled / Disabled
6.3.2.2.5.1.3.	Ascending / Descending
6.3.2.2.5.1.4.	Setpoint (Concentration)
6.3.2.2.5.1.5.	Release Offset (Concentration)

6.3.2.2.5.2. Alarm 2

6.3.2.2.5.2.1.	Relays Assigned (1 – 8)
6.3.2.2.5.2.2.	Enabled / Disabled
6.3.2.2.5.2.3.	Ascending / Descending
6.3.2.2.5.2.4.	Setpoint (Concentration)
6.3.2.2.5.2.5.	Release Offset (Concentration)

6.3.2.2.5.3. Alarm 3

6.3.2.2.5.3.1.	Relays Assigned (1 – 8)
6.3.2.2.5.3.2.	Enabled / Disabled
6.3.2.2.5.3.3.	Ascending / Descending
6.3.2.2.5.3.4.	Setpoint (Concentration)
6.3.2.2.5.3.5.	Release Offset (Concentration)

6.3.2.2.5.4. TWA Alarm

6.3.2.2.5.4.1.	Relays Assigned (1 – 8)
6.3.2.2.5.4.2.	Enabled / Disabled
6.3.2.2.5.4.3.	Ascending / Descending
6.3.2.2.5.4.4.	Setpoint (Concentration)
6.3.2.2.5.4.5.	Avg Time (15, 30 min, 1, 2, 4, 8 hrs)

6.3.2.2.6. Fault Configuration

6.3.2.2.6.1. Head Fail

6.3.2.2.6.1.1.	Relays Assigned (1 – 8)
6.3.2.2.6.1.2.	Enabled / Disabled
6.3.2.2.6.1.3.	Fault Current (>1 to <4mA)

6.3.2.2.6.2. Missing Sensor

6.3.2.2.6.2.1.	Relays Assigned (1 – 8)
6.3.2.2.6.2.2.	Enabled / Disabled
6.3.2.2.6.2.3.	Fault Current (>1 to <4mA)

6.3.2.2.6.3.	Sensor Fail	
6.3.2.2.6.3.1.		Relays Assigned (1 – 8)
6.3.2.2.6.3.2.		Enabled / Disabled
6.3.2.2.6.3.3.		Fault Current (>1 to <4mA)
6.3.2.2.6.4.	Sensor EOL	
6.3.2.2.6.4.1.		Relays Assigned (1 – 8)
6.3.2.2.6.4.2.		Enabled / Disabled
6.3.2.2.6.4.3.		Fault Current (>1 to <4mA)
6.3.2.2.6.4.4.		Current Delay (seconds)
6.3.2.2.6.5.	Output Current Track	
6.3.2.2.6.5.1.		Relays Assigned (1 – 8)
6.3.2.2.6.5.2.		Enabled / Disabled
6.3.2.2.6.5.3.		Fault Current (>1 to <4mA)
6.3.2.2.6.5.4.		Current Delay (seconds)
6.3.2.2.6.6.	Calibration Mode	
6.3.2.2.6.6.1.		Relays Assigned (1 – 8)
6.3.2.2.6.6.2.		Enabled / Disabled
6.3.2.2.6.6.3.		Fault Current (>1 to <4mA)
6.3.2.2.6.7.	Maintenance Mode	
6.3.2.2.6.7.1.		Relays Assigned (1 – 8)
6.3.2.2.6.7.2.		Enabled / Disabled
6.3.2.2.6.7.3.		Fault Current (>1 to <4mA)
6.3.2.2.6.8.	TOD Fail	
6.3.2.2.6.8.1.		Relays Assigned (1 – 8)
6.3.2.2.6.8.2.		Enabled / Disabled
6.3.2.2.6.8.3.		Fault Current (>1 to <4mA)
6.3.2.2.6.8.4.		Current Delay (seconds)
6.3.2.2.6.9.	TOD EOL	
6.3.2.2.6.9.1.		Relays Assigned (1 – 8)
6.3.2.2.6.9.2.		Enabled / Disabled
6.3.2.2.6.9.3.		Fault Current (>1 to <4mA)
6.3.2.2.6.9.4.		Current Delay (seconds)
6.3.2.2.6.10.	Calibration Due	
6.3.2.2.6.10.1.		Relays Assigned (1 – 8)
6.3.2.2.6.10.2.		Enabled / Disabled
6.3.2.2.6.10.3.		Fault Current (>1 to <4mA)
6.3.2.2.6.11.		Current Delay (seconds)
6.3.2.2.6.12.		Days Between

6.3.2.2.7. Relay Matrix

6.3.2.2.7.1.	Alarm 1	Relays Assigned (1 – 8)
6.3.2.2.7.2.	Alarm 2	Relays Assigned (1 – 8)
6.3.2.2.7.3.	Alarm 3	Relays Assigned (1 – 8)
6.3.2.2.7.4.	TWA Alarm	Relays Assigned (1 – 8)
6.3.2.2.7.5.	Head Fail	Relays Assigned (1 – 8)
6.3.2.2.7.6.	Missing Sensor	Relays Assigned (1 – 8)
6.3.2.2.7.7.	Sensor Fail	Relays Assigned (1 – 8)
6.3.2.2.7.8.	Sensor EOL	Relays Assigned (1 – 8)
6.3.2.2.7.9.	Output Current Track	Relays Assigned (1 – 8)
6.3.2.2.7.10.	Calibration Mode	Relays Assigned (1 – 8)
6.3.2.2.7.11.	Maintenance Mode	Relays Assigned (1 – 8)
6.3.2.2.7.12.	TOD Fail	Relays Assigned (1 – 8)
6.3.2.2.7.13.	TOD EOL	Relays Assigned (1 – 8)
6.3.2.2.7.14.	Calibration Due	Relays Assigned (1 – 8)

6.3.2.2.8. TOD Data Review

6.3.2.2.8.1.	Auto Mode	(On / Off)
6.3.2.2.8.2.	Test Day / Time	(Start Date & Time)
6.3.2.2.8.3.	Days Between Tests	(Days After Start and Subsequently)
6.3.2.2.8.4.	Cell Intensity	(0 to 100%)
6.3.2.2.8.5.	Output Indicators	(4 to 20mA Output Dynamic / Static)

6.3.2.2.9. Communications Review

6.3.2.2.9.1. Modbus Communication

6.3.2.2.9.1.1.	Modbus Address	(001 to 255)
6.3.2.2.9.1.2.	Baud Rate	(9600, 19200, 38400)
6.3.2.2.9.1.3.	Parity	(None, Even, Odd)
6.3.2.2.9.1.4.	Start Bit	(1)
6.3.2.2.9.1.5.	Data Bits	(8)
6.3.2.2.9.1.6.	Stop Bit	(1 for Parity, 1 or 2 for No Parity)

6.3.2.2.9.2. Ethernet

6.3.2.2.9.2.1.	IP Address
----------------	------------

6.3.2.2.10. Firmware Review

6.3.2.2.10.1.	Main Firmware Rev
6.3.2.2.10.2.	CH-1 Head Firmware Rev
6.3.2.2.10.3.	CH-1 Sensor Version
6.3.2.2.10.4.	CH-2 Head Firmware Rev
6.3.2.2.10.5.	CH-2 Sensor Version
6.3.2.2.10.6.	Date Format

6.3.2.3. Test On Demand

6.3.2.3.1. 4 to 20mA

6.3.2.4. System Configuration

6.3.2.4.1. Fault Current

6.3.2.4.1.1.	Head Fail	(CH-1 (2) Current)
6.3.2.4.1.2.	Missing Sensor	(CH-1 (2) Current)
6.3.2.4.1.3.	Sensor Fail	(CH-1 (2) Current)
6.3.2.4.1.4.	Sensor EOL	(CH-1 (2) Current & Delay)
6.3.2.4.1.5.	Output Current Track	(CH-1 (2) Current & Delay)
6.3.2.4.1.6.	Calibration Mode	(CH-1 (2) Current)
6.3.2.4.1.7.	Maintenance Mode	(CH-1 (2) Current)
6.3.2.4.1.8.	TOD Fail	(CH-1 (2) Current & Delay)
6.3.2.4.1.9.	TOD EOL	(CH-1 (2) Current & Delay)
6.3.2.4.1.10.	Calibration Due	(CH-1 (2) Current & Delay)

6.3.2.4.2. Relay Configuration

6.3.2.4.2.1.	Relay 1 – 8 (Non-Latching)
6.3.2.4.2.2.	Relay 1 – 8 (Norm Deenergized)
6.3.2.4.2.3.	Relay 1 – 8 (Time Delay)

6.3.2.4.3. Strobe Configuration

6.3.2.4.3.1.	Alarm 1	(CH-1 (2) None, Red, Yellow, Blue)
6.3.2.4.3.2.	Alarm 2	(CH-1 (2) None, Red, Yellow, Blue)
6.3.2.4.3.3.	Alarm 3	(CH-1 (2) None, Red, Yellow, Blue)
6.3.2.4.3.4.	TWA Alarm	(CH-1 (2) None, Red, Yellow, Blue)
6.3.2.4.3.5.	Head Fail	(CH-1 (2) None, Red, Yellow, Blue)
6.3.2.4.3.6.	Missing Sensor	(CH-1 (2) None, Red, Yellow, Blue)
6.3.2.4.3.7.	Sensor Fail	(CH-1 (2) None, Red, Yellow, Blue)
6.3.2.4.3.8.	Sensor EOL	(CH-1 (2) None, Red, Yellow, Blue)
6.3.2.4.3.9.	Output Current Track	(CH-1 (2) None, Red, Yellow, Blue)
6.3.2.4.3.10.	Calibration Mode	(CH-1 (2) None, Red, Yellow, Blue)
6.3.2.4.3.11.	Maintenance Mode	(CH-1 (2) None, Red, Yellow, Blue)
6.3.2.4.3.12.	TOD Fail	(CH-1 (2) None, Red, Yellow, Blue)
6.3.2.4.3.13.	TOD EOL	(CH-1 (2) None, Red, Yellow, Blue)
6.3.2.4.3.14.	Calibration Due	(CH-1 (2) None, Red, Yellow, Blue)

6.3.2.4.4. Alarm Configuration

6.3.2.4.4.1. Alarm 1

6.3.2.4.4.1.1.	Relays Assigned (1 – 8)
6.3.2.4.4.1.2.	Enabled / Disabled
6.3.2.4.4.1.3.	Ascending / Descending
6.3.2.4.4.1.4.	Setpoint (Concentration)
6.3.2.4.4.1.5.	Release Offset (Concentration)

6.3.2.4.4.2. Alarm 2

6.3.2.4.4.2.1.	Relays Assigned (1 – 8)
6.3.2.4.4.2.2.	Enabled / Disabled
6.3.2.4.4.2.3.	Ascending / Descending
6.3.2.4.4.2.4.	Setpoint (Concentration)
6.3.2.4.4.2.5.	Release Offset (Concentration)

6.3.2.4.4.3.	Alarm 3	
6.3.2.4.4.3.1.		Relays Assigned (1 – 8)
6.3.2.4.4.3.2.		Enabled / Disabled
6.3.2.4.4.3.3.		Ascending / Descending
6.3.2.4.4.3.4.		Setpoint (Concentration)
6.3.2.4.4.3.5.		Release Offset (Concentration)
6.3.2.4.4.4.	TWA Alarm	
6.3.2.4.4.4.1.		Relays Assigned (1 – 8)
6.3.2.4.4.4.2.		Enabled / Disabled
6.3.2.4.4.4.3.		Ascending / Descending
6.3.2.4.4.4.4.		Setpoint (Concentration)
6.3.2.4.4.4.5.		Avg Time (15, 30 min, 1, 2, 4, 8 hrs)
6.3.2.4.5.	Fault Configuration	
6.3.2.4.5.1.	Head Fail	
6.3.2.4.5.1.1.		Relays Assigned (1 – 8)
6.3.2.4.5.1.2.		Enabled / Disabled
6.3.2.4.5.1.3.		Fault Current (>1 to <4mA)
6.3.2.4.5.2.	Missing Sensor	
6.3.2.4.5.2.1.		Relays Assigned (1 – 8)
6.3.2.4.5.2.2.		Enabled / Disabled
6.3.2.4.5.2.3.		Fault Current (>1 to <4mA)
6.3.2.4.5.3.	Sensor Fail	
6.3.2.4.5.3.1.		Relays Assigned (1 – 8)
6.3.2.4.5.3.2.		Enabled / Disabled
6.3.2.4.5.3.3.		Fault Current (>1 to <4mA)
6.3.2.4.5.4.	Sensor EOL	
6.3.2.4.5.4.1.		Relays Assigned (1 – 8)
6.3.2.4.5.4.2.		Enabled / Disabled
6.3.2.4.5.4.3.		Fault Current (>1 to <4mA)
6.3.2.4.5.4.4.		Current Delay (seconds)
6.3.2.4.5.5.	Output Current Track	
6.3.2.4.5.5.1.		Relays Assigned (1 – 8)
6.3.2.4.5.5.2.		Enabled / Disabled
6.3.2.4.5.5.3.		Fault Current (>1 to <4mA)
6.3.2.4.5.5.4.		Current Delay (seconds)
6.3.2.4.5.6.	Calibration Mode	
6.3.2.4.5.6.1.		Relays Assigned (1 – 8)
6.3.2.4.5.6.2.		Enabled / Disabled
6.3.2.4.5.6.3.		Fault Current (>1 to <4mA)

6.3.2.4.5.7.	Maintenance Mode	
6.3.2.4.5.7.1.		Relays Assigned (1 – 8)
6.3.2.4.5.7.2.		Enabled / Disabled
6.3.2.4.5.7.3.		Fault Current (>1 to <4mA)
6.3.2.4.5.8.	TOD Fail	
6.3.2.4.5.8.1.		Relays Assigned (1 – 8)
6.3.2.4.5.8.2.		Enabled / Disabled
6.3.2.4.5.8.3.		Fault Current (>1 to <4mA)
6.3.2.4.5.8.4.		Current Delay (seconds)
6.3.2.4.5.9.	TOD EOL	
6.3.2.4.5.9.1.		Relays Assigned (1 – 8)
6.3.2.4.5.9.2.		Enabled / Disabled
6.3.2.4.5.9.3.		Fault Current (>1 to <4mA)
6.3.2.4.5.9.4.		Current Delay (seconds)
6.3.2.4.5.10.	Calibration Due	
6.3.2.4.5.10.1.		Relays Assigned (1 – 8)
6.3.2.4.5.10.2.		Enabled / Disabled
6.3.2.4.5.10.3.		Fault Current (>1 to <4mA)
6.3.2.4.5.10.4.		Current Delay (seconds)
6.3.2.4.5.10.5.		Days Between

6.3.2.4.6. Relay Matrix

6.3.2.4.6.1.	Alarm 1	Relays Assigned (1 – 8)
6.3.2.4.6.2.	Alarm 2	Relays Assigned (1 – 8)
6.3.2.4.6.3.	Alarm 3	Relays Assigned (1 – 8)
6.3.2.4.6.4.	TWA Alarm	Relays Assigned (1 – 8)
6.3.2.4.6.5.	Head Fail	Relays Assigned (1 – 8)
6.3.2.4.6.6.	Missing Sensor	Relays Assigned (1 – 8)
6.3.2.4.6.7.	Sensor Fail	Relays Assigned (1 – 8)
6.3.2.4.6.8.	Sensor EOL	Relays Assigned (1 – 8)
6.3.2.4.6.9.	Output Current Track	Relays Assigned (1 – 8)
6.3.2.4.6.10.	Calibration Mode	Relays Assigned (1 – 8)
6.3.2.4.6.11.	Maintenance Mode	Relays Assigned (1 – 8)
6.3.2.4.6.12.	TOD Fail	Relays Assigned (1 – 8)
6.3.2.4.6.13.	TOD EOL	Relays Assigned (1 – 8)
6.3.2.4.6.14.	Calibration Due	Relays Assigned (1 – 8)

6.3.2.4.7. 4-20 Adjustment

6.3.2.4.7.1.	1mA	(Adjust Counts)
6.3.2.4.7.2.	4mA	(Adjust Counts)
6.3.2.4.7.3.	12mA	(Adjust Counts)
6.3.2.4.7.4.	20mA	(Adjust Counts)

6.3.2.4.8. Communication Setup

6.3.2.4.8.1.	Modbus Communication
--------------	----------------------

6.3.2.4.8.1.1.	Modbus Address (001 to 255)
6.3.2.4.8.1.2.	Baud Rate (9600, 19200, 38400)
6.3.2.4.8.1.3.	Parity (None, Even, Odd)
6.3.2.4.8.1.4.	Start Bit (1)
6.3.2.4.8.1.5.	Data Bits (8)
6.3.2.4.8.1.6.	Stop Bit (1 for Parity, 1 or 2 for No Parity)

6.3.2.4.8.2. Ethernet

6.3.2.4.8.2.1. IP Address

6.3.2.4.9. Set Transmitter Tag

6.3.2.4.9.1. Enter Unique Gas Monitor Tag Name

6.3.2.5. Setup

6.3.2.5.1. Adjust Date/Time

6.3.2.5.1.1. Set Date and Time

6.3.2.5.2. Set Password

6.3.2.5.2.1. Set Three Digit Password (000 to 999)

6.3.2.5.3. Screen Brightness

6.3.2.5.3.1. Increase / Decrease Display Brightness

6.3.2.5.4. LED Brightness

6.3.2.5.4.1. Increase / Decrease LED Brightness

6.3.2.5.5. Self-Test Engineering Menu

6.3.2.5.5.1. Sensidyne Service Only

6.3.3. CHANNEL CONFIGURATION (Sensor CH-1 & CH-2 Submenus)

6.3.3.1. Calibration Mode

6.3.3.1.1. Zero Transmitter

6.3.3.1.1.1. Select Enter When Cal Gas is Applied

6.3.3.1.2. Calibrate

6.3.3.1.2.1. Select Enter When Cal Gas is Applied

6.3.3.1.3. Previous Cal Info

6.3.3.1.3.1. Last Four (4) Successful Calibrations

6.3.3.1.4. Set Cal Gas Conc.

6.3.3.1.4.1. Set Span Gas Concentration

6.3.3.1.5. Sensor Adjustment

6.3.3.1.5.1. Select Cal Gas

6.3.3.1.5.2. Select K-Factor

6.3.3.2. Copy Channel

6.3.3.2.1. Copy Config To CH2 (1)

6.3.3.3. CH-1 (2) Relay Matrix

6.3.3.3.1. Open Relay Matrix

6.3.3.4. Data Review

6.3.3.4.1. Previous Cal Info

6.3.3.4.2. Sensor Status

6.3.3.4.3. Sensor Data

6.3.3.4.4. TOD Data Review

6.3.3.5. TOD Mode

6.3.3.5.1. Auto Mode (On / Off)

6.3.3.5.2. Test Day / Time (Start Date & Time)

6.3.3.5.3. Days Between Tests (Days After Start and Subsequently)

6.3.3.5.4. Cell Intensity (0 to 100%)

6.3.3.5.5. Output Indicators (4 to 20mA Output Dynamic / Static)

7. APPENDIX A: SPECIFICATIONS

General Specifications

Sampling System: Diffusion
Non-Intrusive Magnetic Controls:..... ENTER, ESC, ▲, ▼, ►, ◀

Monitor with Non-Metallic Enclosure

Mounting Requirement: Wall mounted to stud, unistrut, or plate
Dimensions: 9.75" (W) x 20.0" (H) x 6.4" (D)
248 mm (W) x 508 mm (H) x 163 mm (D)
with optional rain shield height 21.5" (546mm)
Weight Range: 9.75-13.75 lbs / 4.4-6.3 kg

Electrical/Electronic Specifications

Power Input Requirements:..... 20-30 VDC
Current Consumption: DC 2.0 A maximum with relays and strobes energized
.....
Output:..... 4-20 mA into 600 ohms
..... User-selectable output current during calibration; ability to test
current loop and adjust output current at the 4 mA and 20 mA
extremes, and Fault Output Current
Relays: 240V, 3A, 50/60 Hz
6A, 120V
6A, 24VDC Resistive
Check points: Enable reading of output current as 10–200 mV.
Transmission Link: 4–20 mA current, non-isolated 2 wires, sourcing
Modbus:..... RS-485, 2 or 4 wires
Fuses:..... Replacement by service personnel only
2 Amp 5x20mm slow blow 250V
Battery: Sealed lead acid 12V 1.4 AH
Overvoltage: Category II

Environmental

Temperature Range: -4°F to 122°F / -20°C to 50°C
Humidity Range:..... 0-90 %RH, non-condensing

Above ratings are subject to sensor limitations.

Ingress Protection: Designed to NEMA 4X or 3R, IPX4 with battery option
Pollution Degree:..... 2
Altitude: Up to 2000m

Approvals: (Refer to Appendix B for full ratings)

System NEC and CEC Class I, CL II, CL III, Div 2, Grps A, B, C, D, E, F, G T4;
Sensor Interface..... NEC and CEC Class I, CL II, CL III, Div 1, Grps A, B, C, D, E, F, G T4;

CE Mark, RoHS Compliant

8. APPENDIX B: APPROVAL RATINGS



WARNING: Substitution of components may impair suitability for Division 2.

AVERTISSEMENT: La substitution de composants peut nuire à l'utilisation dans la Division 2.

WARNING: Do not open enclosure while circuits are live, or when combustible vapors may be present.

AVERTISSEMENT: Ne pas ouvrir le boîtier tandis que les circuits sont sous tension, ou lorsque des vapeurs inflammables peuvent être présents.

CAUTION: Read and understand instruction manual before operating or servicing.

ATTENTION: lire et comprendre le manuel d'instructions avant d'utiliser ou d'entretenir.

CAUTION: The Gas Monitor has been evaluated to EN50270 for electromagnetic compatibility. It is recommended to use shielded interconnect cables for this device.

ATTENTION: Le détecteur de gaz a été évalué selon la norme EN50270 en matière de compatibilité électromagnétique. Il est recommandé d'utiliser des câbles d'interconnexion blindés pour cet appareil.

Install in accordance with Control Drawing Number 099-2053-01 (Appendix G).



NEC/CEC CL I, CL II, CL III, DIV 2, GPS A, B, C, D, E, F, G, T4 with
Intrinsically Safe Sensor Outputs CL I, CL II, CL III, DIV 1, GPS A, B, C, D, E, F, G, T4
When installed with FM Approved Sensors. FM6320, FM6340.



II 3 (1) G Ex ic nA nC [ia Ga] IIC T4 Gc, -20°C < Tamb < +50°, EN 60079-29-1
The most restrictive of -20°C ≤ Tamb ≤ +50°C and Sensor Limit
IECEx Ex ic nA nC [ia Ga] IIC T4 Gc

Input Ratings: 20-30VDC 2A

9. APPENDIX C RECOMMENDED REPLACEMENT PARTS

208-0056-00-R	SensAlarm Flex Strobe Stack Light Base
208-0056-02-R	SensAlarm Flex Strobe Stack Light Red Module
208-0056-04-R	SensAlarm Flex Strobe Stack Light Yellow Module
208-0056-05-R	SensAlarm Flex Strobe Stack Light Green Module
208-0056-06-R	SensAlarm Flex Strobe Stack Light Blue Module
206-0016-01	SensAlarm Flex Replacement Battery (12 VDC)
821-0214-01	Sensor Shield, (Spare / Replacement)
821-0507-01	Plus Series Sensor Holder (Aluminum)
821-0217-01	Sensor Holder O-Ring, (Spare / Replacement)
821-0507-03	Plus Series Sensor Holder (PVC) for use with NH3 and SO2.
827-0506-05-R	Plus Series 316 Stainless Steel Sensor Holder
821-0218-01	Plus Series Sensor Holder (Aluminum) with calibration port - for remote sensors

10. APPENDIX D: TROUBLESHOOTING GUIDE

<i>Symptom</i>	<i>Remedy</i>
Unusual operation at installation of power	
<i>Display irregularities upon initial power application.</i>	Reset system by removing power, waiting 15 seconds and reapplying power. Normal startup should be observed.
No Display	
<i>No power supplied to Monitor</i>	Measure AC voltage at TB1 power distribution board. Measure DC voltage at TB2 power distribution board.
<i>Open fuse</i>	Check fuses 1-4 on power distribution board.
Cannot derive 40 mV at check points, but display shows zero	
<i>Wiring at TB1 of the main board is defective.</i>	Check and correct wiring.
<i>Zero control out of electronics module is defective.</i>	Zero the Monitor. If unsuccessful replace electronics.
After “Zero OK”, display shows a slightly positive value instead of zero	
<i>Presence of target gas.</i>	Normal operation.
After “Zero Failed” 2nd time, display shows a slightly positive value	
<i>Presence of target gas</i>	Normal operation.
<i>A biased sensor (Ammonia or Hydrogen Chloride) has not yet stabilized.</i>	Biased sensors typically take longer to stabilize than non-biased sensors, especially if the bias sensor has become de-stabilized. A destabilized biased sensor may take up to 72 hours to re-stabilize.
<i>Incorrect battery board used for biased sensor.</i>	Check to ensure proper battery bias board is used.
<i>Sensor is damaged or defective.</i>	Replace suspect sensor with a backup sensor known to be good. Repeat start-up procedure. If display shows slightly positive value, gas is present. If display shows zero, suspect sensor is bad.
Screen shows that span calibration has failed.	
<i>Calibration gas concentration is incorrect.</i>	Verify calibration gas concentration with a detector tube and assure proper delivery of calibration gas to sensor assembly.
<i>Sensor is defective.</i>	Replace sensor assembly.
<i>Sensor Interface Assembly is defective.</i>	Replace Sensor Interface Assembly.
Monitor shows “Missing Sensor” on display.	
<i>Sensor assembly is loose or missing.</i>	Make certain sensor assembly is properly installed. This can be tested by removing and reinserting the sensor. Make certain sensor head unit is properly connected to the power supply board.

Monitor displays garbled characters.

Sensor assembly not correctly installed. Remove sensor, wait 10 seconds, and then reinstall sensor in sensor holder.

Relay(s) assigned to alarm condition(s) do not activate.

Relays not assigned. Verify that relay(s) desired for each alarm condition have, in fact, been assigned. Go to System Configuration/Alarm Settings/Alarm Functions/Alarms 1, 2, 3, and/or TWA. "Relays assigned _____" will be displayed. Use the Add Relay function to assign the relay(s) for that alarm.

Time delay is not set as desired for each relay. Go to System Configuration/Alarm Settings/Alarm Functions/Relays 1, 2, 3, 4, and/or Warn current-Relay5 and set the desired time delay for each relay.

Alarm is disabled. Go to System Configuration/Alarm Settings/Alarm Functions/Alarms 1, 2, 3, and/or TWA and enable the alarm(s).

Alarm is incorrectly set as ascending or descending. Go to System Configuration/Alarm Settings/Alarm Functions/Alarms 1, 2, 3, and/or TWA and correctly set the alarm(s) as ascending or descending.

Alarm setpoint has been incorrectly set. Go to System Configuration/Alarm Settings/Alarm Functions/Alarms 1, 2, 3, and/or TWA and correctly set the alarm setpoint(s).

11. APPENDIX E: RETURNED MATERIAL AUTHORIZATION (RMA)

Sensidyne maintains an instrument service facility at the factory to provide its customers with both warranty and non-warranty repair. Sensidyne assumes no liability for service performed by personnel other than authorized Sensidyne personnel. To facilitate the repair process, please contact the Sensidyne Service Department in advance for assistance with the problem which cannot be remedied and / or requires the return of the product to the factory. All returned products require a Returned Material Authorization (RMA) number. Sensidyne Service Department personnel may be reached at:

Sensidyne, LP
1000 112th Circle N, Suite 100
St. Petersburg, FL 33716 USA
800-451-9444 [U.S. Toll Free]
+1 727-530-3602 [Main]
+1 727-538-0671 [Service Fax]
email: info@sensidyne.com

All non-warranty repair orders will have a minimum fee assessed whether the repair is authorized or not. This fee includes handling, administration, and technical expenses for inspecting the instrument and providing an estimate. However, the estimate fee is waived if the repair is authorized. If you wish to set a limit to the authorized repair cost, state a “not to exceed” figure on your purchase order. Please indicate if a price quotation is required before authorization of the repair cost, understanding that this invokes extra cost and handling delay. The Sensidyne repair policy is to perform all necessary repairs to restore the instrument to its full operating condition.

Repairs are handled in a “first in - first out” basis. Your order may be expedited if you authorize an expediting fee. This will place your order next in line behind orders currently in process. Pack the instrument and its accessories (preferably in their original packing) and enclose your return address, purchase order, shipping and billing information, RMA number, a description of the problem encountered with your instrument and any special instructions. All prices are subject to change without notice.

If this is the first time you are dealing directly with the factory, you will be asked to prepay or to authorize a COD shipment.

Send the instrument, prepaid, to:

SENSIDYNE
1000 112th CIRCLE N, SUITE 100
ST. PETERSBURG, FL 33716 USA
ATTENTION: Service Department
RMA #: _____

SERVICE OPTIONS

The Sensidyne Service Department offers a variety of service options which will minimize costly interruptions and maintenance costs. These options include initial training, on-site technical assistance, and full factory repairs. Sensidyne has developed several programs which offer options best suited to your applications and needs. For further information, contact the Sensidyne Service Department at the following numbers: 800-451-9444 • +1 727-530-3602 • +1 727-538-0671 [Service Fax].

12. APPENDIX F: CONFIGURATION REFERENCE

Password is: **NONE** • Monitor P/N _____ • Monitor S/N _____

Sensor 1 (Gas) _____ (Conc.) _____ (P/N) _____ ToD Cell P/N _____

Calibration Gas Concentration _____ ppm %LEL %vol

Sensor 2 (Gas) _____ (Conc.) _____ (P/N) _____ ToD Cell P/N _____

Calibration Gas Concentration _____ ppm %LEL %vol

Head 1 ToD Mode Adjustment

Auto Mode Enable: Disabled Enabled • Days Between Tests _____ • Cell Intensity _____%

Output Indicators: None 4-20 Current Loop

Head 2 ToD Mode Adjustment

Auto Mode Enable: Disabled Enabled • Days Between Tests _____ • Cell Intensity _____%

Output Indicators: None 4-20 Current Loop

ALARM FUNCTIONS:

Head 1 Alarm Settings

Relays Assigned	Alarm 1	Alarm 2	Alarm 3	TWA Alarm
1	<input checked="" type="checkbox"/>	<input checked="" type="checkbox"/>	<input type="checkbox"/>	<input type="checkbox"/>
2	<input type="checkbox"/>	<input type="checkbox"/>	<input type="checkbox"/>	<input type="checkbox"/>
3	<input type="checkbox"/>	<input type="checkbox"/>	<input type="checkbox"/>	<input type="checkbox"/>
4	<input type="checkbox"/>	<input type="checkbox"/>	<input type="checkbox"/>	<input type="checkbox"/>
5	<input type="checkbox"/>	<input type="checkbox"/>	<input type="checkbox"/>	<input type="checkbox"/>
6	<input type="checkbox"/>	<input type="checkbox"/>	<input type="checkbox"/>	<input type="checkbox"/>
7	<input type="checkbox"/>	<input type="checkbox"/>	<input type="checkbox"/>	<input type="checkbox"/>
8	<input type="checkbox"/>	<input type="checkbox"/>	<input type="checkbox"/>	<input type="checkbox"/>
Enabled	<input checked="" type="checkbox"/>	<input checked="" type="checkbox"/>	<input type="checkbox"/>	<input type="checkbox"/>
Disabled	<input type="checkbox"/>	<input type="checkbox"/>	<input checked="" type="checkbox"/>	<input checked="" type="checkbox"/>
Ascending	<input checked="" type="checkbox"/>	<input checked="" type="checkbox"/>	<input checked="" type="checkbox"/>	<input checked="" type="checkbox"/>
Descending	<input type="checkbox"/>	<input type="checkbox"/>	<input type="checkbox"/>	<input type="checkbox"/>
Setpoint	_____	_____	_____	_____
Release Offset	<u> 3% </u>	<u> 3% </u>	<u> 3% </u>	<u> 3% </u>
Average Time Adjust for TWA Alarm	<input type="checkbox"/> 15m <input type="checkbox"/> 30m <input type="checkbox"/> 60m <input type="checkbox"/> 2h <input type="checkbox"/> 4h <input checked="" type="checkbox"/> 8h			

ALARM FUNCTIONS (Continued):

Head 2 Alarm Settings

Relays Assigned	Alarm 1	Alarm 2	Alarm 3	TWA Alarm
1	<input checked="" type="checkbox"/>	<input checked="" type="checkbox"/>	<input checked="" type="checkbox"/>	<input type="checkbox"/>
2	<input type="checkbox"/>	<input type="checkbox"/>	<input type="checkbox"/>	<input type="checkbox"/>
3	<input type="checkbox"/>	<input type="checkbox"/>	<input type="checkbox"/>	<input type="checkbox"/>
4	<input type="checkbox"/>	<input type="checkbox"/>	<input type="checkbox"/>	<input type="checkbox"/>
5	<input type="checkbox"/>	<input type="checkbox"/>	<input type="checkbox"/>	<input type="checkbox"/>
6	<input type="checkbox"/>	<input type="checkbox"/>	<input type="checkbox"/>	<input type="checkbox"/>
7	<input type="checkbox"/>	<input type="checkbox"/>	<input type="checkbox"/>	<input type="checkbox"/>
8	<input type="checkbox"/>	<input type="checkbox"/>	<input type="checkbox"/>	<input type="checkbox"/>
Enabled	<input checked="" type="checkbox"/>	<input checked="" type="checkbox"/>	<input checked="" type="checkbox"/>	<input type="checkbox"/>
Disabled	<input type="checkbox"/>	<input type="checkbox"/>	<input type="checkbox"/>	<input checked="" type="checkbox"/>
Ascending	<input checked="" type="checkbox"/>	<input checked="" type="checkbox"/>	<input checked="" type="checkbox"/>	<input checked="" type="checkbox"/>
Descending	<input type="checkbox"/>	<input type="checkbox"/>	<input type="checkbox"/>	<input type="checkbox"/>
Setpoint	_____	_____	_____	_____
Release Offset	<u>3%</u>	<u>3%</u>	<u>3%</u>	<u>3%</u>
Average Time Adjust for TWA Alarm		<input type="checkbox"/> 15m <input type="checkbox"/> 30m	<input type="checkbox"/> 60m <input type="checkbox"/> 2h	<input type="checkbox"/> 4h <input checked="" type="checkbox"/> 8h

FAULT FUNCTIONS:

Head 1 Fault Settings

Relays Assigned	Head Fail	Missing Sensor	Sensor Fail	Sensor End Of Life	Output Current Track	Cal Mode	Cal Due	Maint. Mode	ToD Fail	ToD End Of Life
1	<input type="checkbox"/>	<input type="checkbox"/>	<input type="checkbox"/>	<input type="checkbox"/>	<input type="checkbox"/>	<input type="checkbox"/>	<input type="checkbox"/>	<input type="checkbox"/>	<input type="checkbox"/>	<input type="checkbox"/>
2	<input type="checkbox"/>	<input type="checkbox"/>	<input type="checkbox"/>	<input type="checkbox"/>	<input type="checkbox"/>	<input type="checkbox"/>	<input type="checkbox"/>	<input type="checkbox"/>	<input type="checkbox"/>	<input type="checkbox"/>
3	<input type="checkbox"/>	<input type="checkbox"/>	<input type="checkbox"/>	<input type="checkbox"/>	<input type="checkbox"/>	<input type="checkbox"/>	<input type="checkbox"/>	<input type="checkbox"/>	<input type="checkbox"/>	<input type="checkbox"/>
4	<input checked="" type="checkbox"/>	<input checked="" type="checkbox"/>	<input checked="" type="checkbox"/>	<input type="checkbox"/>	<input type="checkbox"/>	<input checked="" type="checkbox"/>	<input checked="" type="checkbox"/>	<input checked="" type="checkbox"/>	<input type="checkbox"/>	<input type="checkbox"/>
5	<input type="checkbox"/>	<input type="checkbox"/>	<input type="checkbox"/>	<input type="checkbox"/>	<input type="checkbox"/>	<input type="checkbox"/>	<input type="checkbox"/>	<input type="checkbox"/>	<input type="checkbox"/>	<input type="checkbox"/>
6	<input type="checkbox"/>	<input type="checkbox"/>	<input type="checkbox"/>	<input type="checkbox"/>	<input type="checkbox"/>	<input type="checkbox"/>	<input type="checkbox"/>	<input type="checkbox"/>	<input type="checkbox"/>	<input type="checkbox"/>
7	<input type="checkbox"/>	<input type="checkbox"/>	<input type="checkbox"/>	<input type="checkbox"/>	<input type="checkbox"/>	<input type="checkbox"/>	<input type="checkbox"/>	<input type="checkbox"/>	<input type="checkbox"/>	<input type="checkbox"/>
Enabled	<input checked="" type="checkbox"/>	<input checked="" type="checkbox"/>	<input checked="" type="checkbox"/>	<input type="checkbox"/>	<input type="checkbox"/>	<input checked="" type="checkbox"/>	<input checked="" type="checkbox"/>	<input checked="" type="checkbox"/>	<input type="checkbox"/>	<input type="checkbox"/>
Disabled	<input type="checkbox"/>	<input type="checkbox"/>	<input type="checkbox"/>	<input checked="" type="checkbox"/>	<input checked="" type="checkbox"/>	<input type="checkbox"/>	<input type="checkbox"/>	<input type="checkbox"/>	<input checked="" type="checkbox"/>	<input checked="" type="checkbox"/>
Fault Current	<u>3.0</u>	<u>3.0</u>	<u>3.0</u>	<u>3.0</u>	<u>3.0</u>	<u>3.0</u>	<u>3.0</u>	<u>3.0</u>	<u>3.0</u>	<u>3.0</u>
Current Delay (sec)	NA	NA	NA	<u>10</u>	<u>10</u>	NA	<u>10</u>	NA	<u>10</u>	<u>10</u>
Days Between	NA	NA	NA	<u>NA</u>	<u>NA</u>	NA	<u>30</u>	NA	<u>NA</u>	<u>NA</u>

Head 2 Fault Settings

Relays Assigned	Head Fail	Missing Sensor	Sensor Fail	Sensor End Of Life	Output Current Track	Cal Mode	Cal Due	Maint. Mode	ToD Fail	ToD End Of Life
1	<input type="checkbox"/>	<input type="checkbox"/>	<input type="checkbox"/>	<input type="checkbox"/>	<input type="checkbox"/>	<input type="checkbox"/>	<input type="checkbox"/>	<input type="checkbox"/>	<input type="checkbox"/>	<input type="checkbox"/>
2	<input type="checkbox"/>	<input type="checkbox"/>	<input type="checkbox"/>	<input type="checkbox"/>	<input type="checkbox"/>	<input type="checkbox"/>	<input type="checkbox"/>	<input type="checkbox"/>	<input type="checkbox"/>	<input type="checkbox"/>
3	<input type="checkbox"/>	<input type="checkbox"/>	<input type="checkbox"/>	<input type="checkbox"/>	<input type="checkbox"/>	<input type="checkbox"/>	<input type="checkbox"/>	<input type="checkbox"/>	<input type="checkbox"/>	<input type="checkbox"/>
4	<input checked="" type="checkbox"/>	<input checked="" type="checkbox"/>	<input checked="" type="checkbox"/>	<input type="checkbox"/>	<input type="checkbox"/>	<input checked="" type="checkbox"/>	<input checked="" type="checkbox"/>	<input checked="" type="checkbox"/>	<input type="checkbox"/>	<input type="checkbox"/>
5	<input type="checkbox"/>	<input type="checkbox"/>	<input type="checkbox"/>	<input type="checkbox"/>	<input type="checkbox"/>	<input type="checkbox"/>	<input type="checkbox"/>	<input type="checkbox"/>	<input type="checkbox"/>	<input type="checkbox"/>
6	<input type="checkbox"/>	<input type="checkbox"/>	<input type="checkbox"/>	<input type="checkbox"/>	<input type="checkbox"/>	<input type="checkbox"/>	<input type="checkbox"/>	<input type="checkbox"/>	<input type="checkbox"/>	<input type="checkbox"/>
7	<input type="checkbox"/>	<input type="checkbox"/>	<input type="checkbox"/>	<input type="checkbox"/>	<input type="checkbox"/>	<input type="checkbox"/>	<input type="checkbox"/>	<input type="checkbox"/>	<input type="checkbox"/>	<input type="checkbox"/>
Enabled	<input checked="" type="checkbox"/>	<input checked="" type="checkbox"/>	<input checked="" type="checkbox"/>	<input type="checkbox"/>	<input type="checkbox"/>	<input checked="" type="checkbox"/>	<input checked="" type="checkbox"/>	<input checked="" type="checkbox"/>	<input type="checkbox"/>	<input type="checkbox"/>
Disabled	<input type="checkbox"/>	<input type="checkbox"/>	<input type="checkbox"/>	<input checked="" type="checkbox"/>	<input checked="" type="checkbox"/>	<input type="checkbox"/>	<input type="checkbox"/>	<input type="checkbox"/>	<input checked="" type="checkbox"/>	<input checked="" type="checkbox"/>
Fault Current	<u>3.0</u>	<u>3.0</u>	<u>3.0</u>	<u>3.0</u>	<u>3.0</u>	<u>3.0</u>	<u>3.0</u>	<u>3.0</u>	<u>3.0</u>	<u>3.0</u>
Current Delay (sec)	NA	NA	NA	<u>10</u>	<u>10</u>	NA	<u>10</u>	NA	<u>10</u>	<u>10</u>
Days Between	NA	NA	NA	<u>NA</u>	<u>NA</u>	NA	<u>30</u>	NA	<u>NA</u>	<u>NA</u>

SensAlarm Flex – Universal Gas Detection System

RELAY CONFIGURATIONS:

	Relay 1	Relay 2	Relay 3	Relay 4	Relay 5	Relay 6	Relay 7	Relay 8
Norm Energized	<input type="checkbox"/>	<input type="checkbox"/>	<input type="checkbox"/>	<input checked="" type="checkbox"/>	<input type="checkbox"/>	<input type="checkbox"/>	<input type="checkbox"/>	<input type="checkbox"/>
Norm De-Energized	<input checked="" type="checkbox"/>	<input checked="" type="checkbox"/>	<input checked="" type="checkbox"/>	<input type="checkbox"/>	<input checked="" type="checkbox"/>	<input checked="" type="checkbox"/>	<input checked="" type="checkbox"/>	<input checked="" type="checkbox"/>
Latching	<input checked="" type="checkbox"/>	<input type="checkbox"/>	<input type="checkbox"/>	<input type="checkbox"/>	<input type="checkbox"/>	<input type="checkbox"/>	<input type="checkbox"/>	<input type="checkbox"/>
Non-Latching	<input type="checkbox"/>	<input checked="" type="checkbox"/>	<input checked="" type="checkbox"/>	<input checked="" type="checkbox"/>	<input checked="" type="checkbox"/>	<input checked="" type="checkbox"/>	<input checked="" type="checkbox"/>	<input checked="" type="checkbox"/>
Time Delay (sec)	<u>3</u>	<u>3</u>	<u>3</u>	<u>3</u>	<u>3</u>	<u>3</u>	<u>3</u>	<u>3</u>

COMBUSTIBLE SENSOR CONFIGURATIONS:

Head 1 – Selected CMB Cal Gas Methane Propane Other _____

Selected K Factor (CB = Catalytic Bead, IR = Infrared)

	CB-Methane	CB-Propane	CB-Other	IR-Methane	IR-Propane	IR-Other
None	<input checked="" type="checkbox"/>	<input checked="" type="checkbox"/>	<input checked="" type="checkbox"/>	<input checked="" type="checkbox"/>	<input checked="" type="checkbox"/>	<input checked="" type="checkbox"/>
Hydrogen	<input type="checkbox"/>	<input type="checkbox"/>				
Propane	<input type="checkbox"/>	<input type="checkbox"/>				
Hexane	<input type="checkbox"/>	<input type="checkbox"/>			<input type="checkbox"/>	
Butane	<input type="checkbox"/>	<input type="checkbox"/>			<input type="checkbox"/>	
Methanol		<input type="checkbox"/>			<input type="checkbox"/>	
Butadiene		<input type="checkbox"/>			<input type="checkbox"/>	
Custom K Factor is:	<u>1</u>	<u>1</u>	<u>1</u>		<u>1</u>	<u>1</u>

Head 2 – Selected CMB Cal Gas Methane Propane Other _____

Selected K Factor (CB = Catalytic Bead, IR = Infrared)

	CB-Methane	CB-Propane	CB-Other	IR-Methane	IR-Propane	IR-Other
None	<input checked="" type="checkbox"/>	<input checked="" type="checkbox"/>	<input checked="" type="checkbox"/>	<input checked="" type="checkbox"/>	<input checked="" type="checkbox"/>	<input checked="" type="checkbox"/>
Hydrogen	<input type="checkbox"/>	<input type="checkbox"/>				
Propane	<input type="checkbox"/>	<input type="checkbox"/>				
Hexane	<input type="checkbox"/>	<input type="checkbox"/>			<input type="checkbox"/>	
Butane	<input type="checkbox"/>	<input type="checkbox"/>			<input type="checkbox"/>	
Methanol		<input type="checkbox"/>			<input type="checkbox"/>	
Butadiene		<input type="checkbox"/>			<input type="checkbox"/>	
Custom K Factor is:	<u>1</u>	<u>1</u>	<u>1</u>		<u>1</u>	<u>1</u>

HORN & STROBE CONFIGURATION:

Head 1 Alarms

	Yellow	Red	Blue	Horn
Alarm 1	<input type="checkbox"/>	<input checked="" type="checkbox"/>	<input type="checkbox"/>	<input type="checkbox"/>
Alarm 2	<input type="checkbox"/>	<input checked="" type="checkbox"/>	<input type="checkbox"/>	<input type="checkbox"/>
Alarm 3	<input type="checkbox"/>	<input checked="" type="checkbox"/>	<input type="checkbox"/>	<input type="checkbox"/>
TWA Alarm	<input type="checkbox"/>	<input type="checkbox"/>	<input type="checkbox"/>	<input type="checkbox"/>

Head 1 Faults

	Yellow	Red	Blue	Horn
Head Fail	<input checked="" type="checkbox"/>	<input type="checkbox"/>	<input type="checkbox"/>	<input type="checkbox"/>
Missing Sensor	<input checked="" type="checkbox"/>	<input type="checkbox"/>	<input type="checkbox"/>	<input type="checkbox"/>
Sensor Fail	<input checked="" type="checkbox"/>	<input type="checkbox"/>	<input type="checkbox"/>	<input type="checkbox"/>
Sensor End of Life	<input type="checkbox"/>	<input type="checkbox"/>	<input type="checkbox"/>	<input type="checkbox"/>
Output Current Track	<input type="checkbox"/>	<input type="checkbox"/>	<input type="checkbox"/>	<input type="checkbox"/>
Cal Mode	<input checked="" type="checkbox"/>	<input type="checkbox"/>	<input type="checkbox"/>	<input type="checkbox"/>
Cal Due	<input checked="" type="checkbox"/>	<input type="checkbox"/>	<input type="checkbox"/>	<input type="checkbox"/>
Maintenance Mode	<input checked="" type="checkbox"/>	<input type="checkbox"/>	<input type="checkbox"/>	<input type="checkbox"/>
ToD Fail	<input type="checkbox"/>	<input type="checkbox"/>	<input type="checkbox"/>	<input type="checkbox"/>
ToD End of Life	<input type="checkbox"/>	<input type="checkbox"/>	<input type="checkbox"/>	<input type="checkbox"/>

Head 2 Alarms

	Yellow	Red	Blue	Horn
Alarm 1	<input type="checkbox"/>	<input checked="" type="checkbox"/>	<input type="checkbox"/>	<input type="checkbox"/>
Alarm 2	<input type="checkbox"/>	<input checked="" type="checkbox"/>	<input type="checkbox"/>	<input type="checkbox"/>
Alarm 3	<input type="checkbox"/>	<input checked="" type="checkbox"/>	<input type="checkbox"/>	<input type="checkbox"/>
TWA Alarm	<input type="checkbox"/>	<input type="checkbox"/>	<input type="checkbox"/>	<input type="checkbox"/>

Head 2 Faults

	Yellow	Red	Blue	Horn
Head Fail	<input checked="" type="checkbox"/>	<input type="checkbox"/>	<input type="checkbox"/>	<input type="checkbox"/>
Missing Sensor	<input checked="" type="checkbox"/>	<input type="checkbox"/>	<input type="checkbox"/>	<input type="checkbox"/>
Sensor Fail	<input checked="" type="checkbox"/>	<input type="checkbox"/>	<input type="checkbox"/>	<input type="checkbox"/>
Sensor End of Life	<input type="checkbox"/>	<input type="checkbox"/>	<input type="checkbox"/>	<input type="checkbox"/>
Output Current Track	<input type="checkbox"/>	<input type="checkbox"/>	<input type="checkbox"/>	<input type="checkbox"/>
Cal Mode	<input checked="" type="checkbox"/>	<input type="checkbox"/>	<input type="checkbox"/>	<input type="checkbox"/>
Cal Due	<input checked="" type="checkbox"/>	<input type="checkbox"/>	<input type="checkbox"/>	<input type="checkbox"/>
Maintenance Mode	<input checked="" type="checkbox"/>	<input type="checkbox"/>	<input type="checkbox"/>	<input type="checkbox"/>
ToD Fail	<input type="checkbox"/>	<input type="checkbox"/>	<input type="checkbox"/>	<input type="checkbox"/>
ToD End of Life	<input type="checkbox"/>	<input type="checkbox"/>	<input type="checkbox"/>	<input type="checkbox"/>

13. APPENDIX G: CERTIFICATION INSTALLATION DRAWING

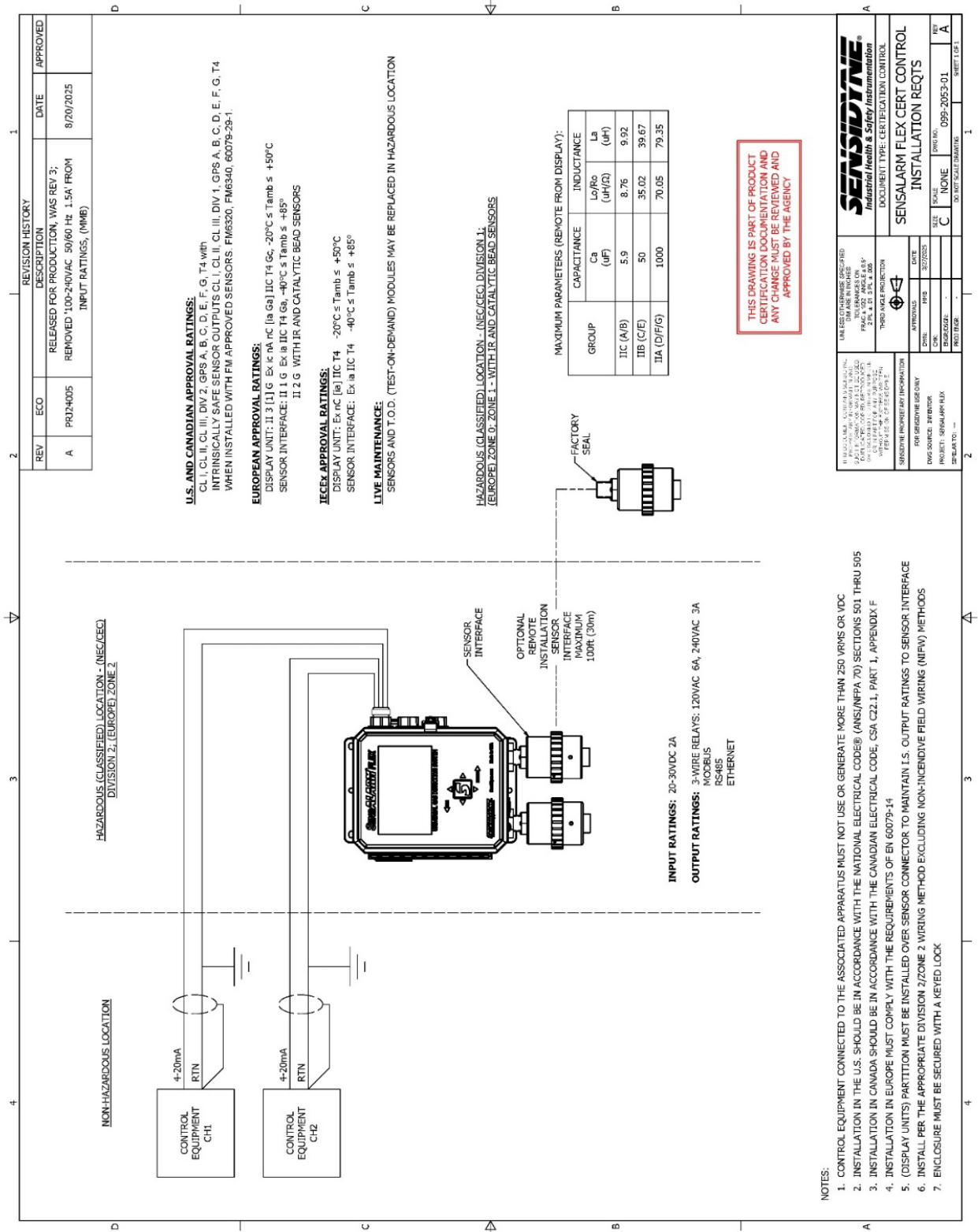

Manufactured by:

Sensidyne, LP
1000 112th Circle N, Suite 100
St. Petersburg, Florida 33716
USA

800-451-9444 • 727-530-3602 • 727-539-0550 [fax]
www.Sensidyne.com • info@Sensidyne.com

Authorized EU Representative

Schauenburg Electronic Technologies GmbH
Weseler Str. 35 · 45478
Mülheim-Ruhr Germany

+49 (0) 208 9 99 10 • +49 (0) 208 5 41 10 [fax]
www.schauenburg.com • international@schauenburg.com

SENSIDYNE[®]

Sensidyne, LP

1000 112th Circle N, Suite 100
St. Petersburg, Florida 33716 USA
800-451-9444 • +1 727-530-3602 • +1 727-539-0550 [fax]
web: www.sensidyne.com • e-mail: info@sensidyne.com