

**Viability of the Gilibrator as Calibration Standard for
Gas Flow Meters**

Otmar Schmid

Cloud and Aerosol Science Laboratory
University of Missouri-Rolla
G7 Norwood Hall
Rolla, MO 65401

oschmid@umr.edu
Tel.: (573) 341 4370

Rolla, 06/04/1998

Symbols and Abbreviations

b	Intercept of the calibration curve determined by the Gilibrator
e, e _s	Water vapor pressure, saturation vapor pressure,
e ₀	Vapor pressure upstream of Gilibrator
e _{Gil}	Vapor pressure in flow cell and downstream of Gilibrator
F	Filter
FM	Flow meter
G	Gilibrator
hPa	100 Pa
m	Slope of calibration curve determined by the Gilibrator
MFM	Mass flow meter
nlm	Normal liter per minute (normal conditions: T ₀ = 0 C, p ₀ = 1013 hPa)
NV	Needle valve
p, p _a , p _i	Pressure, ambient pressure, partial pressure of component i
p ₀	Reference pressure for mass flow units (standard, normal temperature)
Q _{Gil}	Gilibrator flow rate (reading of Gilibrator)
Q _{cal}	Q _{Gil} converted into the corresponding flow rate measured by the FM
Q _{Gil.cor}	Q _{Gil} corrected for pressure, temperature, and vapor pressure
Q _{m.Gil}	Q _{Gil} converted into mass flow rate
Q _{v.Gil}	Q _{Gil} converted into the corresponding flow rate measured by the VFM
Q _{VFM} , Q _{FM}	Flow rate measured by the VFM and FM, respectively
Q _{actual}	Corrected flow rate determined by the FM utilizing the Gilibrator calibration
R	Repeatability of FM
RD	Relative difference between FM flow rate and corrected Gilibrator flow rate (Q _{FM} - Q _{Gil.cor})/Q _{Gil.cor}
RH	Relative humidity
slm	Standard liter per minute (standard conditions: T ₀ = 70 F, p ₀ = 1013 hPa)
T	Temperature
T ₀	Reference temperature for mass flow units (standard, normal temperature)
V, V _i	Volume of gas, partial volume of component I
v	Number of moles of gas
σ	Relative standard deviation (accuracy, uncertainty) of the FM and Gilibrator combined
σ _{cal}	Relative standard deviation (accuracy, uncertainty) of Gilibrator including Pressure, temperature, and vapor pressure measurement
σ _{Gil}	Relative standard deviation (accuracy, uncertainty) of the Gilibrator
σ _Q	Relative standard deviation (accuracy, uncertainty) of Q _{actual}

1	Experiment	1
	1.1 Experimental Setup	1
	1.2 Experimental Procedure	2
2	Theory of Data Analysis	3
	2.1 Volumetric Flow Meter	3
	2.1.1 Downstream Configuration	
	2.1.2 Upstream Configuration	3
	2.2 Mass Flow Calibration	5
	2.2.1 Relationship between Volumetric and Mass Flow Rate	5
	2.2.2 Downstream Configuration	6
	2.2.3 Upstream Configuration	6
3	Instrumentation	7
4	Vapor Content in High Flow Cell	8
	4.1 Background and Units	8
	4.2 Vapor Data	9
5	Error Analysis	10
	5.1 Error Propagation	
	5.2 Uncertainty of Gilibrator Calibration	10
	5.3 Agreement between Gilibrator and Flow Meter	11
6	Gilibrator Assessment	12
	6.1 Mass Flow Measurements	12
	6.1.1 Downstream Configuration	12
	6.1.2 Upstream Configuration	13
	6.2 Volumetric Flow Calibration	14
	6.2.1 Downstream Configuration	14
	6.2.1 Upstream Configuration	15
7	Conclusions and Recommendations	16
	7.1 Conclusions	16
	7.2 Recommendations	16

Calibration of Gas Flow Meters Using the Gilibrator-2

The objective of this study is to test the performance of the Gilibrator-2 as a calibration standard for gas flow meters (FM). This paper will discuss 1) two different experimental setups for calibrating a flow meter with the Gilibrator, 2) a derivation of the mathematical formalism required for error analysis and calibration of a FM, 3) an intercomparison of the Gilibrator with both a volumetric (VFM) and a mass flow meter (MFM), and 4) a detailed, step-by-step guideline for an actual calibration. Agreement of the Gilibrator with both the VFM and the MFM is achieved, provided the appropriate pressure, temperature and water vapor corrections are applied. The accuracy of the Gilibrator, specified as better than 1% of the reading (Gilibrator manual), is sufficient for calibration of the vast majority of commercially available flow meters.

The Gilibrator is a primary volumetric flow standard. A soap film bubble traverses between two infrared sensors. As the film bubble passes the first infrared sensor an electronic clock is started. The clock is stopped at time t , when the bubble reaches the second infrared sensor. The volume V swept out by the moving bubble is accurately known. Hence the volumetric flow rate can be calculated by dividing volume V by time t .

The "calibration of a FM" and the "assessment of the performance of the Gilibrator using a FM" are basically the same processes. The only difference is, that the objective of the calibration is to achieve agreement between the FM and the Gilibrator by calculating appropriate calibration coefficients for the FM, while the assessment judges the degree of agreement without applying any calibration factors. Both terms can be used interchangeably throughout this report.

1 Experiment

1.1 Experimental Setup

For the assessment of the Gilibrator performance, as for any calibration of a flow meter, the Gilibrator and the FM are arranged in a series configuration. Figure 1 depicts schematically the two possible experimental setups: The FM can be located upstream or downstream of the Gilibrator.

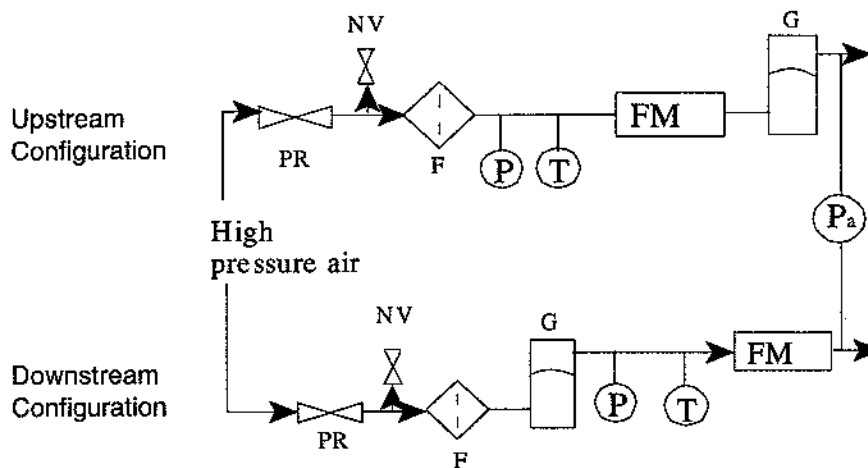

Figure 1: The two possible calibration configurations: The FM to be calibrated is located upstream or downstream of the Gilibrator G.

Clean dry air, supplied by a house high pressure air line, provides a steady air flow free of pressure pulses. The high pressure air passes through a pressure regulator PR, which reduces the pressure to about ambient pressure p_a . The high pressure air source can be substituted by a high pressure source of any kind of gas. The performance of the Gilibrator is independent of the type of gas, as long as the integrity of the wetted parts is guaranteed. The gas flow through the FM and the Gilibrator is adjusted by needle valve NV which regulates the dump flow. As a protective measure for the FM a filter F downstream of PR guarantees aerosol particle free calibration air. The gas temperature and pressure are measured by a temperature and pressure sensor T and p, respectively. In some cases also the ambient pressure p_a has to be measured. The significance of the pressure and temperature measurement will be discussed in the data analysis section.

Difference between upstream and downstream configuration

The fundamental difference between the upstream and the downstream configuration lies in the fact, that the Gilibrator itself can add to the gas flow rate. The soap solution in the Gilibrator provides a liquid water surface resulting in evaporation of water molecules into the calibration air. Hence the gas flow increases as the air passes through the Gilibrator. This vapor effect can enhance the flow by up to about 3 % depending on the vapor content of the compressed air, and on pressure and temperature in the Gilibrator. A detailed discussion of this vapor effect will be presented below.

1.2 Experimental Procedure

The step by step procedure of how to calibrate a gas FM by means of the Gilibrator is as follows. Please refer to Figure 1 for a flow schematic.

- 1) Assemble the experimental setup according to Figure 1 with PR closed in order to prevent premature flow through the system. The downstream method is preferred (see conclusion).
- 2) Close NV in the dump flow line and open cautiously PR until FM reaches full scale. While opening NV1 always watch the pressure gauge and make sure the Gilibrator is not exposed to more than its specified maximum overpressure (**number?**). Hence even for calibrating a volumetric FM a pressure gauge is recommended, even though it is not required for data interpretation.
- 3) Use NV2 to adjust the desired flow rate through FM.
- 4) Wait until the flow through the system is stable. Then take at least 5 Gilibrator readings per flow rate and calculate the average flow rate (the average is automatically provided by the Gilibrator).
- 5) Record the FM and the average Gilibrator reading, as well as pressure and temperature, if required.
- 6) For a reliable calibration covering the whole measurement range of the FM a five point calibration is recommended, taking data at 20, 40, 60, 80 and 100 % of full scale of the FM. Hence items 3 through 5 have to be repeated as needed. Some flow meters saturate at less than 100% of full scale. In this case, alternatively to the 100 % point a 90 or 95 % value is preferable.

2 Theory of Data Analysis

2.1 Volumetric Flow Meter

2.1.1 Downstream Configuration

In the downstream configuration (Figure 1), the flow through the Gilibrator Q_{Gil} and the flow downstream of it $Q_{Gil,down}$, where FM is located, are identical. (see section 1.1)

$$Q_{Gil,down} = Q_{Gil} \quad (1)$$

Hence for ideal devices (no measurement errors and no pressure drop across VFM or Gilibrator) the flow measured by the Gilibrator should be equal to the VFM value. No correction factor has to be applied.

The pressure drop across the Gilibrator is smaller than 5 hPa and is therefore negligible at room pressure.

The pressure drop across the VFM depends on the type of VFM. If the pressure drop is of the order of 1% of the ambient pressure, the Gilibrator flow rate has to be corrected for pressure in order to maintain the Gilibrator accuracy of 1%. Most commercially available flow meters display a significant pressure drop for the full scale flow rate. Hence the volumetric flow rates upstream and downstream of the VFM are different. Depending on the application a calibration with respect to the upstream pressure may be preferable or vice versa.

If the VFM is to be calibrated with respect to its upstream pressure Q_{Gil} does not have to be corrected for pressure since both the Gilibrator and the inlet of the VFM are at the same pressure. Hence the "corrected" volumetric Gilibrator flow rate $Q_{v,Gil}$ is

$$Q_{v,Gil} = Q_{Gil} \quad (1a)$$

However if the VFM is to be calibrated with respect to its downstream pressure the following pressure correction has to be applied

$$Q_{v,Gil} = Q_{Gil} \frac{p}{p_a} \quad (1b)$$

where p is the Gilibrator pressure and p_a is the ambient pressure. This equation follows from the general gas law (equation 3), which will be introduced in the following section.

2.1.2 Upstream Configuration

In the upstream configuration the flow rate upstream of the Gilibrator, where the FM is located, is not necessarily identical to the flow rate passing through the flow cell of the Gilibrator due to the vapor effect. If Q_{vap} is the flow rate induced by the additional vapor, the flow rate upstream of the Gilibrator can be expressed as

$$Q_{Gil,up} = Q_{Gil} - Q_{vap} \quad (2)$$

where Q_{Gil} is the flow rate measured by the Gilibrator.

At room temperature and pressure gases can be approximated as ideal gases. Hence the ideal gas law (3) can be used to derive an expression for Q_{vap} .

$$p \cdot V = v \cdot R \cdot T \quad (3)$$

p, T, V, v : pressure, temperature, volume, and number of moles of gas
 R : general gas constant (8.31 J/(mol K))

Consider a gas in a volume V and at pressure p with n different components. If the molecules of each component i are collected in a separate region within V maintaining pressure p constant, each component i will occupy a partial volume V_i , with $\sum V_i = V$. Also if all components except component i are removed from volume V the pressure in V will assume the partial pressure p_i , with $\sum p_i = p$. Using the ideal gas law (3) the following relationship between partial volume V_i , partial pressure p_i , total volume V and pressure p can be derived

$$V_i = \frac{p_i}{p} \cdot V \quad (4)$$

For the Gilibrator we have to consider a gas consisting of two components, air and water vapor. Assume, for the sake of simplicity, that the air upstream of the Gilibrator does not contain any water vapor molecules. Then, according to (4), the partial volume of the vapor V_{vap} added to the air by the Gilibrator can be expressed as

$$V_{vap} = \frac{e}{p} \cdot V \quad (5)$$

where e is the water vapor pressure, p the total pressure in the flow cell of the Gilibrator, and V the volume of the gas in the flow cell. Similar for the partial volume and pressure of the air in the flow cell

$$V_{air} = \frac{p_{air}}{p} \cdot V \quad (6)$$

Since the gas upstream of the Gilibrator does not contain any vapor, the pressure and volume upstream of the Gilibrator are equal to the partial pressure and volume of air, respectively.

$$p_{up} = p_{air} \quad V_{up} = V_{air} \quad (7)$$

The sum over all partial pressures has to yield the total pressure p in the flow cell. Hence $p = p_{up} + e$, which implies.

$$p_{up} = p - e \quad (8)$$

Using (7) and (8), equation (6) can be written as

$$V_{up} = V \cdot \left(1 - \frac{e}{p}\right) \quad (9)$$

Since the volumetric flow rates behave like the volume we find for the flow rate upstream of the Gilibrator

$$Q_{Gil,up} = Q_{Gil} \left(1 - \frac{e}{p} \right) \quad (10)$$

The above derivation assumed perfectly dry air entering the Gilibrator. If the air upstream of the Gilibrator is not completely dry but rather has a vapor pressure e_0 equation (10) becomes:

$$Q_{Gil,up} = Q_{Gil} \left(1 - \frac{e - e_0}{p} \right) \quad (11)$$

This is the desired relationship between the volumetric flow rate upstream of the Gilibrator $Q_{Gil,up}$, where the VFM is located, and the flow rate measured by the Gilibrator Q_{Gil} . Hence the vapor corrected Gilibrator flow rate is

$$Q_{v,Gil} = Q_{Gil} \left(1 - \frac{e - e_0}{p} \right) \quad (11a)$$

Equation (11a) is correct only, if the VFM is calibrated with respect to its downstream pressure. Similar to the downstream configuration, a pressure correction has to be applied, if the reference pressure of the VFM is its upstream pressure.

$$Q_{v,Gil} = Q_{Gil} \left(1 - \frac{e - e_0}{p} \right) \cdot \frac{p}{p_{up}} \quad (11b)$$

where p is the Gilibrator pressure and p_{up} is the pressure upstream of the VFM.

Equations (1a), (1b), (11a), and (11b) provide the basis for the calibration of a VFM in the downstream and upstream mode, respectively. All four equations, except (1a) require correction factors. Only the downstream configuration with a VFM calibrated with respect to its upstream pressure does not require any additional measurements, other than the flow measurements of the Gilibrator and the VFM.

2.2 Mass Flow Calibration

2.2.1 Relationship between volumetric and mass flow rate

It is common practice to display the mass flow rate in units of volume per time. This sometimes gives rise to confusion. How can a mass flow rate, which should have units of mass per time, be expressed in terms of volume per time, which are the units of volumetric flow rate? The reason becomes evident, if the mass m of the gas is expressed according to the general gas law (3)

$$m = v \cdot M = \frac{p \cdot V}{R \cdot T} \quad (12)$$

where M is the molar mass of the gas. If we derive (12) by time t for constant pressure p and temperature T and note that $dm/dt = \Phi_m$ (mass flow rate) and $dV/dt = Q_v$ (volumetric flow rate), we can write

$$\Phi_m = Q_v \cdot \frac{p}{R \cdot T} \quad (13)$$

Hence the mass flow rate Φ_m is unambiguously related to the volumetric flow rate Q_v , if a reference pressure and temperature p_0 and T_0 , respectively, are specified. The two common reference conditions are the standard condition ($T_0 = 273.15 \text{ K}$, $p_0 = 1013 \text{ hPa} = 1 \text{ atm}$) and the normal condition ($T_0 = 0 \text{ C}$, $p_0 = 1013 \text{ hPa}$).

The relationship between the mass flow rate Φ_m in l/min and the volumetric flow rate Q_v is derived as follows. Consider a mass m at two different conditions say V, p, T and V_0, p_0, T_0 . (12) gives

$$m = \frac{p \cdot V}{R \cdot T} = \frac{p_0 \cdot V_0}{R \cdot T_0} \quad (14)$$

which means
$$V_0 = V \cdot \frac{p}{p_0} \cdot \frac{T_0}{T} \quad (15)$$

If p_0 and T_0 are standard pressure and temperature, respectively, then V_0 is the standard volume the gas of mass m occupies. Hence, the mass flow rate Q_m in standard liters per minute is given by

$$Q_m = Q_v \cdot \frac{p}{p_0} \cdot \frac{T_0}{T} \quad (16)$$

where Q_v is the volumetric flow rate at pressure p and temperature T in liter per minute.

The mass flow rate Q_m , given in standard liters per minute, represents the volumetric flow rate one would have, if the gas were at standard conditions.

2.2.2 Downstream Configuration

The volumetric flow rate of the Gilibrator can be converted into mass flow rate according to (16)

$$Q_{m,Gil} = Q_{Gil} \cdot \frac{p}{p_0} \cdot \frac{T_0}{T} \quad (17)$$

p_0, T_0 : standard pressure and temperature
 p, T : pressure and temperature in Gilibrator
 Q_{Gil} : Gilibrator reading
 $Q_{m,Gil}$: mass flow according to the Gilibrator

It is obvious from (17), that pressure and temperature in the flow cell of the Gilibrator have to be measured for a mass flow calibration. Please note, that similar to the VFM, there is no vapor correction required for the downstream configuration.

2.2.3 Upstream Configuration

The analysis of the upstream configuration has to include the vapor correction for the same reasons given in chapter 2.1.2. Combining (11) and (16) we find the upstream mass flow rate determined by the Gilibrator to be

$$Q_{m,Gil} = Q_{Gil} \cdot \frac{p}{p_0} \cdot \frac{T_0}{T} \cdot \left(1 - \frac{e - e_0}{p} \right) \quad (18)$$

3 Instrumentation

The assessment of the performance of the Gilibrator is based on data provided by a high accuracy MFM and a VFM. Converting the Gilibrator flow rate into the corresponding flow rate measured by the MFM or VFM requires pressure, temperature, and vapor content data. This chapter provides an overview of the employed instrumentation.

Pressure and temperature probes

The pressure measurement was performed by a mechanical pressure gauge from Wallace and Tiernan (Model FA 129 KK 09032), which is accurate to within 1.6 torr. The temperature probe was a Cole-Parmer Thermistor, series 400, with a specified accuracy of 0.2 K.

Dew point hygrometer

The vapor pressure of the air was measured by a Cambridge Dew Point Hygrometer (Model 992-C1) The relationship between dew point temperature and vapor content is given below. (19)

MFM

A 0 - 20 slm thermal mass flow meter (Omega, Model FMA-8510) was used for these experiments. It had been newly calibrated by the manufacturer with a specified accuracy of 1 % of full scale. The MFM showed a zero offset of 0.06 slm. Subtracting the zero offset from the actual reading yields the mass flow rate measured by the MFM.

VFM

The volumetric flow rate was measured by a 0 - 1 l/min Cole-Parmer non-thermal gas flow meter (Model 32915-14). It measures the pressure drop across a laminar flow element. This pressure drop is converted into volumetric flow rate. The specified accuracy of the VFM is 2 % of the reading plus 0.01 l/min.

The VFM data were compared to the "standard flow cell" of the Gilibrator, which has an operation range of 0.02 - 6 l/min. The maximum flow rate of the MFM however required the "high flow cell" (2 - 30 l/min).

4 Vapor Content in the High Flow Cell

The soap solution of the Gilibrator humidifies the calibration air. A quantitative investigation of this effect can be performed by measuring the vapor content of the calibration air upstream and downstream of the Gilibrator. A Cambridge dew point hygrometer was employed to measure the vapor content of the air. The hygrometer requires a minimum sample flow of 1 l/min. Hence the water vapor content could only be monitored for the high flow cell of the Gilibrator. Throughout this report the term "vapor" will be used as abbreviation for "water "vapor".

4.1 Background and Units

The vapor content of a gas can be expressed in terms of the partial pressure of the vapor (vapor pressure). Any closed system with a gas-water interface will eventually reach an equilibrium state, where as many vapor molecules escape from the liquid to the gas phase as do from the gas to the liquid phase. The hereby established equilibrium vapor pressure is called the saturation vapor pressure. The saturation vapor pressure for a plain, unpolluted water surface depends only on temperature and can be approximated as (Rogers and Yau, 1989)

$$e_s(T) = 6.112 \cdot \exp\left(\frac{17.67 \cdot T}{T + 243.5}\right) \quad (19)$$

where the saturation vapor pressure e_s is in hPa and T is in degrees C. This formula agrees with the actual saturation vapor pressure to within 0.1 % over the temperature range $-30 \text{ C} < T < 35 \text{ C}$. The saturation vapor pressure e_s increases exponentially with temperature. Hence the higher the temperature the larger is the amount of vapor present in the gas phase.

Another common unit for the vapor content is the dew point temperature T_{dew} . The dew point temperature is defined as the temperature a gas must be cooled or heated to, with pressure and vapor content held constant, for it to reach saturation with respect to bulk water. Hence the vapor pressure e of a gas with dew point temperature T_{dew} is given by (19) as $e = e_s(T_{\text{dew}})$. The relative humidity RH of a gas with dew point temperature T_{dew} at temperature T is then defined as

$$\text{RH} = \frac{e}{e_s(T)} = \frac{e_s(T_{\text{dew}})}{e_s(T)} \quad (19a)$$

It is noteworthy, that for a given vapor pressure e , the RH depends on the temperature, since the denominator of (19a) is a function of T .

Governing parameters for vapor effect

The amount of vapor added to the calibration air in the Gilibrator depends mainly on three factors: the volumetric flow rate, the temperature, and the vapor content of the calibration air *entering* the Gilibrator.

Volumetric flow rate and residence time of the gas in the flow cell are inversely proportional. Hence more water will evaporate from the soap solution, if the flow rate is small. In the extreme case of no flow at all the air in the Gilibrator will reach saturation, which means the maximum amount of vapor has been added to the calibration air by the Gilibrator.

The driving force for evaporation is RH, the ratio of the actual vapor pressure e to the saturation vapor pressure e_s (19a). Since e_s is a function of temperature, RH depends on the temperature. Hence the gas temperature affects the amount of vapor added by the Gilibrator.

The vapor emission by the Gilibrator also depends on the vapor content of the air upstream of the Gilibrator. If the actual vapor pressure e equals the saturation vapor pressure e_s , i.e. RH = 100 %, no net evaporation takes place, i.e. there is no vapor effect. On the other hand for absolutely dry air the vapor effect is most pronounced. For air at 23 C and 1013 hPa the flow rate increases by 2.8 % due to the vapor effect.

4.2 Vapor Data

The following data were taken for the high flow cell. Due to the dependence on temperature and vapor content upstream of the Gilibrator these results, strictly speaking, only apply to this particular set of experimental conditions. However approximations for other experimental conditions can be inferred from them.

The dew point temperature upstream of the Gilibrator was constant over the course of these experiments. The hygrometer measured - 8.7 F (-22.6 C), which corresponds to a RH of 3.6 % at 23 C. According to (19) the vapor pressure upstream of the Gilibrator e_0 is 1.00 hPa.

Figure 2 shows the vapor content measured downstream of the Gilibrator as a function of volumetric flow rate.

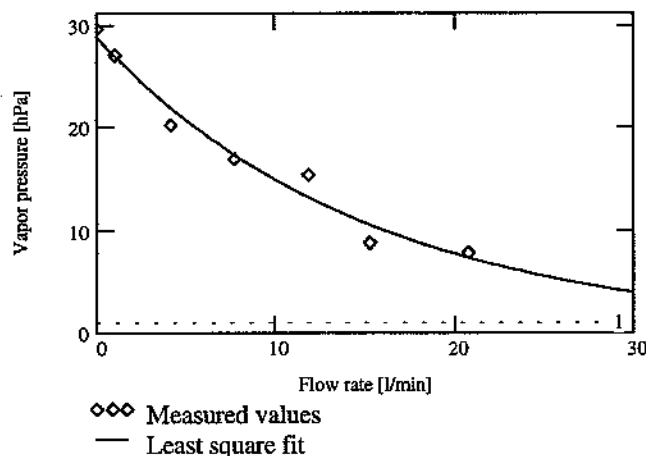

Figure 2: Vapor pressure downstream of the high flow cell of the Gilibrator as a function of volumetric flow rate at 22.6 +/- 1.2 C. The dashed line marks the vapor pressure $e_0 = 1.00$ hPa upstream of the Gilibrator.

Due to the reduced residence time with increasing flow rate the vapor pressure e_{Gil} downstream of the Gilibrator asymptotically reaches its upstream value $e_0 = 1.00$ hPa for large flow rates. The data point at zero flow was added, assuming saturated conditions. The saturation vapor pressure at the present temperature of 23.8 C is 29.5 hPa according to (19). A least square fit of the data provides an expression for the vapor pressure e_{Gil} in the flow cell and downstream of it

$$e_{Gil} = 28.70 \cdot \exp(-0.0660 \cdot Q_{Gil}) \quad (20)$$

where the volumetric flow rate through the Gilibrator Q_{Gil} is in liters per minute and e_{Gil} is in hPa. This equation allows us to calculate the vapor pressure in the high flow cell for any volumetric flow rate, provided the temperature is about 23 C and the air entering the Gilibrator is dry (RH < 20 %).

5 Error Analysis

5.1 Propagation of Errors

The law of error propagation states for the uncertainty Δf of a quantity f , which is a function of the measured parameters x and y

$$\Delta f = \sqrt{\left(\frac{\delta f}{\delta x} \cdot \Delta x\right)^2 + \left(\frac{\delta f}{\delta y} \cdot \Delta y\right)^2} \quad (21)$$

where $\delta f/\delta x$ indicates the partial derivative of f with respect to x and Δx , Δy are the measurement uncertainties of x and y . (Gerthsen, et al.)

5.2 Uncertainty of Gilibrator Calibration

The calculation of an upper limit for the uncertainty of the flow measurement with the Gilibrator is based on applying the laws of error propagation on (18). Equation (18) represents the worst case, since it requires the maximum number of individual measurements: Gilibrator flow rate, pressure, temperature, and vapor content. According to (21) the accuracy of the Gilibrator flow measurement including all conversion factors is given by

$$\Delta Q_{m,Gil} = \sqrt{\left(\frac{\delta Q_{m,Gil}}{\delta Q_{Gil}} \cdot \Delta Q_{Gil}\right)^2 + \left(\frac{\delta Q_{m,Gil}}{\delta p} \cdot \Delta p\right)^2 + \left(\frac{\delta Q_{m,Gil}}{\delta T} \cdot \Delta T\right)^2 + \left(\frac{\delta Q_{m,Gil}}{\delta e} \cdot \Delta e\right)^2 + \left(\frac{\delta Q_{m,Gil}}{\delta e_0} \cdot \Delta e_0\right)^2} \quad (22)$$

It proves useful to convert the absolute accuracy of the measurement $\Delta Q_{m,Gil}$ into a relative uncertainty. This is achieved by dividing (22) by (18). The relative uncertainty or standard deviation σ_{cal} can then be expressed as

$$\sigma_{cal} = \frac{\Delta Q_{m,Gil}}{Q_{m,Gil}} = \sqrt{\left(\frac{\Delta Q_{Gil}}{Q_{Gil}}\right)^2 + \left(\frac{\Delta p}{p}\right)^2 + \left(\frac{e - e_0}{p^2} \cdot \Delta p\right)^2 + \left(\frac{\Delta T}{T}\right)^2 + \left[\left(\frac{\Delta e}{p}\right)^2 + \left(\frac{\Delta e_0}{p}\right)^2\right]} \quad (23)$$

The relative uncertainty of the Gilibrator itself $\Delta Q_{Gil}/Q_{Gil}$ is specified as less than 1% of the reading.

The accuracy of the pressure measurement is 0.25 % at 1 atm and the uncertainty of the temperature probe is 0.07 %.

The standard deviation due to the vapor pressure correction, which is given by the last two terms, can be neglected, since both e and e_0 , and hence Δe and Δe_0 , are much smaller than p , since p is about room pressure and e and e_0 are not greater than 32 hPa at room temperature. Due to the same reason the third term in the radical of (23) can be neglected.

Substituting these values into (23) yields

$$\sigma_{cal} = \sqrt{1 + 0.25^2 + 0.07^2} = 1.0\% \quad (24)$$

It is noteworthy that the uncertainty added to the Gilibrator measurement due to pressure and temperature measurement is negligibly small compared to the Gilibrator uncertainty. Obviously this statement is only true for this particular set of measurement devices. If different pressure and

temperature probes are used, (24) would have to be reevaluated. But accuracies of less than 0.5 % for pressure and temperature probes are fairly common for commercially available probes. Assuming both devices provide an accuracy of 0.5 % at the actual calibration conditions the total uncertainty

becomes $\sigma_{cal} = \sqrt{1 + 0.5^2 + 0.5^2} = 1.118\%$, which is still sufficient for meaningful FM calibrations.

5.3 Agreement between Gilibrator and Flow Meter

An ideal instrument would always display the correct measurement value. The comparison of two of those ideal devices would yield perfect agreement. Since it is inherently impossible to build such ideal probes we can not expect the Gilibrator and the FM to agree perfectly. Assume the relative standard deviations of the Gilibrator, including pressure, temperature, and vapor measurement, and the FM are σ_{cal} and σ_{FM} , respectively. The total standard deviation is then

$$\sigma = \sqrt{\sigma_{cal}^2 + \sigma_{FM}^2} \quad (25)$$

Two devices agree within their accuracy, if at least 68 % of all data points agree to within σ and at least 95 % to within 2σ . (Kneubuehl, 1988)

The relative error of the 0 - 1l/min VFM is 2% of the reading plus 0.01 l/min. Hence the standard deviation σ for the VFM - Gilibrator system

$$\sigma = \sqrt{1^2 + \left[2 + \frac{0.01 \cdot \frac{\text{liter}}{\text{min}}}{Q_{VFM}} \right]^2} \geq 3.2\% \quad (26)$$

where σ is in % . σ assumes its minimum value of 3.2 % for the largest possible flow rate, which is 1 l/min in this case.

The manufacturer of the 0 -20 slm MFM specifies the measurement uncertainty as 1% of full scale. Substituting this in (25) yields

$$\sigma = \sqrt{1^2 + \left(\frac{0.2 \cdot \text{slm}}{Q_{MFM}} \right)^2} \geq 1.4\% \quad (27)$$

where the minimum standard deviation corresponds to the maximum flow rate of 20 slm.

6 Gilibrator Assessment

6.1 Mass Flow Measurements

The range of the MFM, 0 - 20 slm, suggested the use of the high flow cell of the Gilibrator, which has a specified range of 2 to 30 l/min.

6.1.1 Downstream configuration

Figure 3 depicts the data for the MFM measurements in the downstream configuration, listed in appendix 1, table 1. The volumetric flow rate of the Gilibrator has been converted into mass flow rate according to (17).

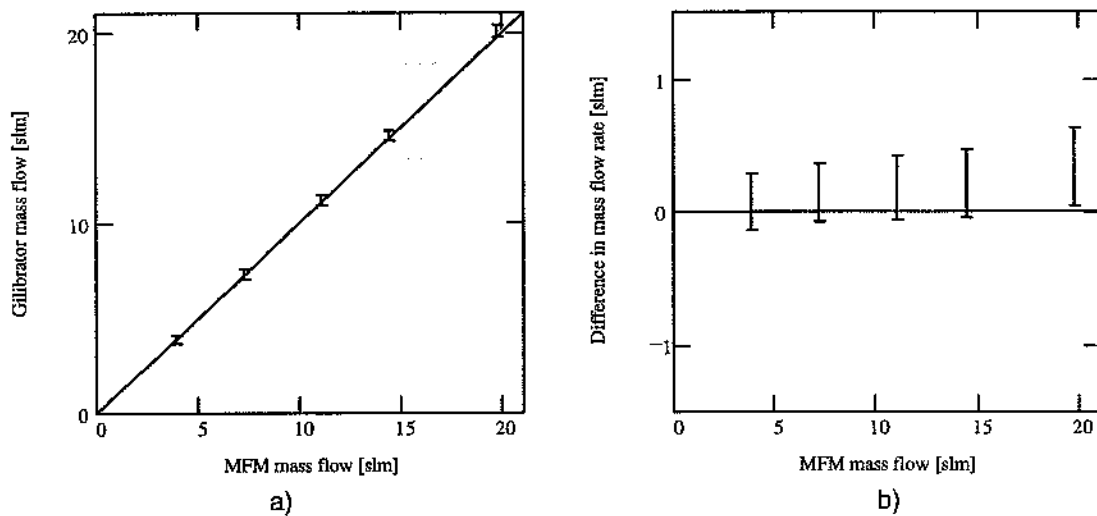

Figure 3: Comparison of the mass flow rate measured by the Gilibrator and the MFM in the downstream configuration. The error bars indicate the $\pm \sigma$ range, which represents the statistical uncertainty of the measurements.

a) Plot of the MFM measurements versus the Gilibrator flow rates. For reference perfect agreement is illustrated by the solid line.

b) The same data as on the left side, but enhanced resolution by plotting the difference of the Gilibrator and MFM flow rate ($Q_{m,Gil} - Q_{MFM}$) versus MFM flow rate.

The left part of figure 3 demonstrates the high degree of linearity of the measurements. For better assessment of the agreement of both devices, the difference of the Gilibrator and the MFM values are plotted versus the mass flow in the graph on the right. The error bars represent the $\pm \sigma$ range calculated according to (27).

Gilibrator and MFM measurements agree within the one σ range for four out of the five data points. The 19.75 l/min value lies in the 2σ regime. Hence according to the theory of error propagation the Gilibrator and the MFM agree to within their specifications.

All Gilibrator values are larger than the corresponding MFM values and show an upwards trend for increasing flow rate, which suggests a systematic error. Even though there is agreement between Gilibrator and MFM these data can be used to improve the accuracy of the MFM by correcting for this trend. The details of the calibration will be presented in appendix 2.

6.1.2 Upstream configuration

Figure 4 depicts the data for the MFM measurements in the upstream configuration, listed in appendix, table 2. The volumetric flow rate of the Gilibrator has been converted into mass flow rate according to (18).

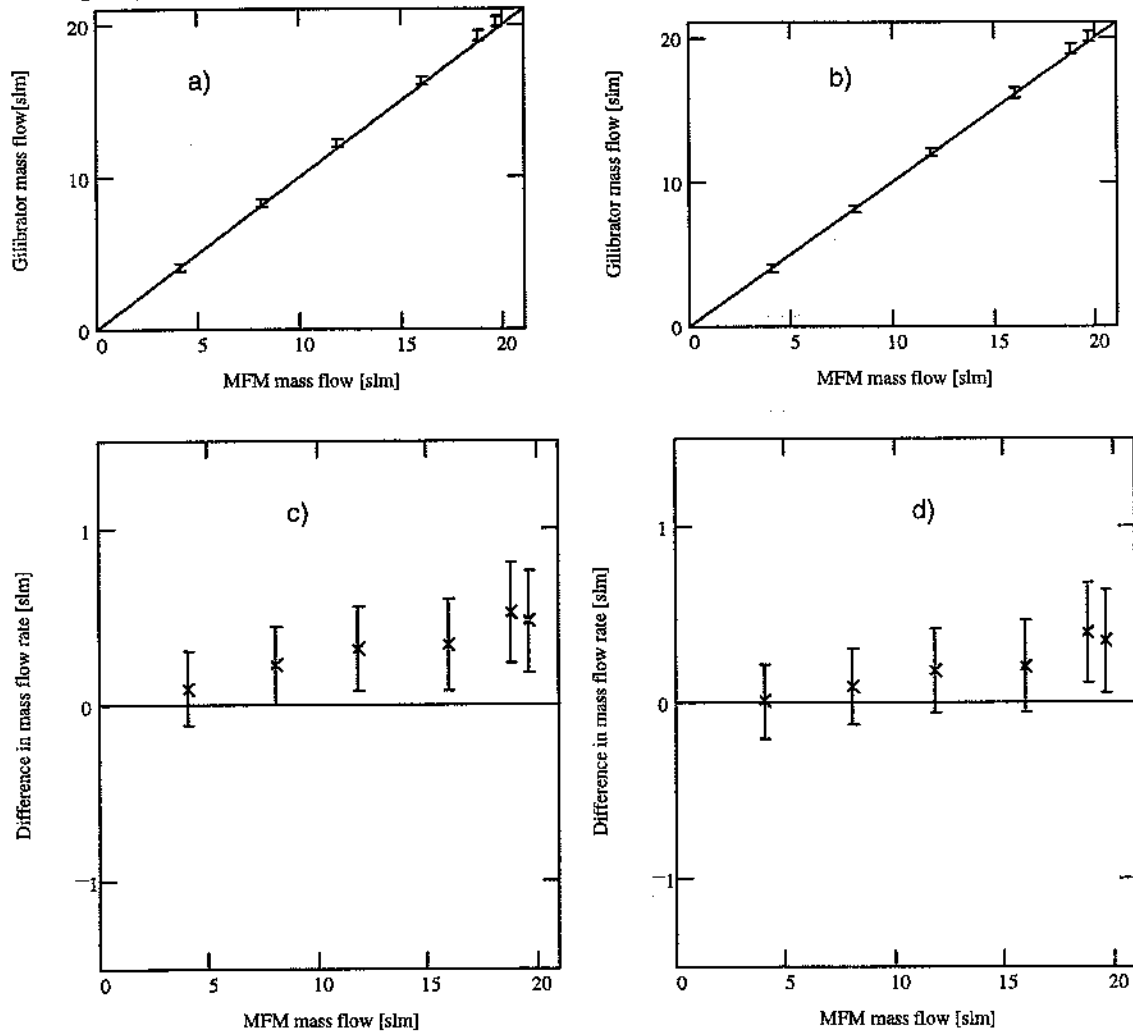

Figure 4: Comparison of the mass flow rate measured by the Gilibrator and the MFM in the downstream configuration. The error bars indicate the $\pm \sigma$ range, which represents the statistical uncertainty of the measurements.

a) Plot of the Gilibrator mass flow rate versus the MFM measurement ignoring the vapor effect.

b) Plot of the Gilibrator mass flow with vapor correction versus MFM data.

c) and d) Equivalent graphs to a) and b), but enhanced resolution by plotting the difference of the Gilibrator and MFM flow rate ($Q_{m,Gil} - Q_{MFM}$) versus MFM flow rate.

The Gilibrator mass flow for the data presented in b) and d) of Figure 4 have been calculated from equation (18). The graphs a) and c) of Figure 4 are based on the same data, but the vapor effect has not been included by letting e be equal to e_0 in (18). Without vapor correction, only two out of six data points agree to within the one σ range. Hence the Gilibrator and the MFM do not agree to within their specifications. However for the vapor corrected measurements four data points lie within the one σ region, and all six are within the 2σ range. This indicates agreement between Gilibrator and MFM within their specified accuracies. Thus for the upstream configuration the vapor correction has to be applied to achieve agreement between the MFM and the Gilibrator.

6.2 Volumetric Flow Calibration

A 0 - 1 l/min VFM was used to assess the performance of the standard flow cell of the Gilibrator, which has a manufacturer specified range of 0.02 to 6 l/min.

6.2.1 Downstream configuration

Figure 5 depicts the data for the VFM measurements in the downstream configuration, listed in appendix 1, table 4.

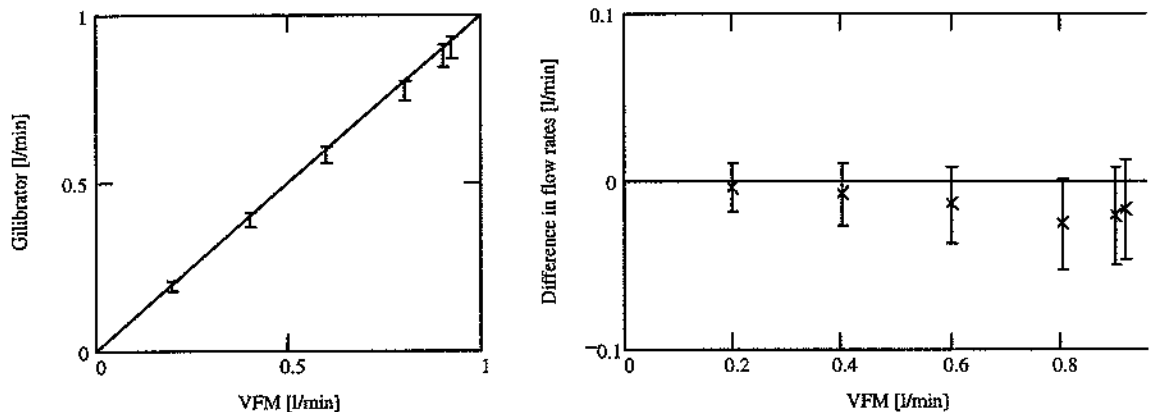

Figure 5: Comparison of the volumetric flow rates measured by the Gilibrator and the MFM in the downstream configuration. The error bars indicate the $\pm \sigma$ range, which represents the statistical uncertainty of the measurements. σ has been calculated using (26).

a) Plot of VFM flow measurement versus Gilibrator flow. For reference perfect agreement is illustrated by the solid line.

b) Plot of difference of the Gilibrator flow and the VFM flow ($Q_{v,Gil} - Q_{VFM}$) versus the VFM flow rate.

The manufacturer calibrates the VFM with respect to its downstream pressure. Therefore the pressure correction according to (1b) has been applied to calculate the flow rates of the Gilibrator corresponding to the VFM. The error bars of all six data points intersect the zero line (line of perfect agreement). Hence the two devices agree within their specified accuracies.

The Gilibrator measures consistently less flow than the VFM, which suggests a systematic error of the VFM. This can be corrected by performing a calibration with the Gilibrator. Please refer to appendix 2 for details.

Upstream configuration

Figure 6 depicts the data for the VFM measurements in the upstream configuration, listed in appendix 1, table 5.

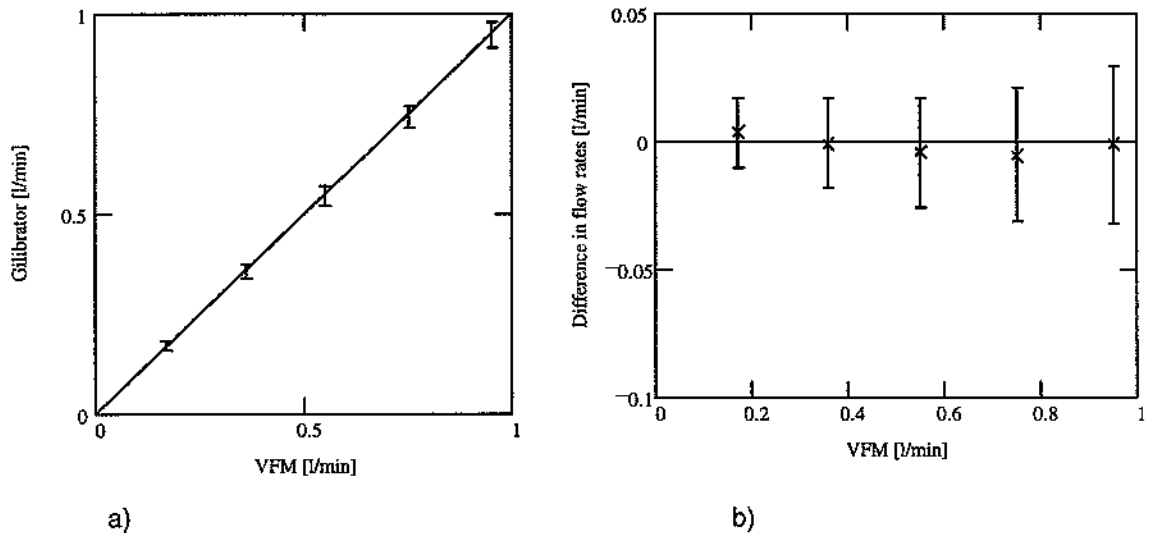

Figure 6: Comparison of the volumetric flow rates measured by the Gilibrator and the VFM in the upstream configuration. The standard deviation σ has been calculated according to (26).

a) Plot of VFM flow measurement versus Gilibrator flow. The line represents perfect agreement between Gilibrator and VFM.

b) Plot of difference of the Gilibrator flow and the VFM flow ($Q_{v,Gil} - Q_{VFM}$) versus the VFM flow rate.

Equation (11a) has been applied for converting the Gilibrator flow into the corresponding flow measured by the VFM. However, as stated previously (section 4), due to limitations of the hygrometer no data for the vapor pressures are available. Hence the vapor correction factor in (11a) was set to 1, which means the vapor effect has been neglected.

Nevertheless all six data points indicate agreement between the VFM and the Gilibrator. This is not surprising, since the vapor effect is only expected to be about 2% of the reading (for flow rates between 0.2 and 1 l/min), which is less than the standard deviations ranging from 3.2 to 7.8% (see appendix 1 table 5). Hence the vapor effect may remain undetected by the VFM, due to its relatively large measurement uncertainty.

7 Conclusions and Recommendations

7.1 Conclusions

The performance of the standard and high flow cell of the Gilibrator has been tested. A newly calibrated MFM with high accuracy and a VFM were used as reference instruments. After including the required pressure, temperature, and vapor corrections both instruments agreed well within their specified uncertainties. The calibration procedure and the data analysis are simple. The Gilibrator proved its utility and reliability as a calibration standard for gas FMs in the range between 0.2 to 20 l/min.

7.2 Recommendations

Upstream - downstream configuration

As part of this study two different experimental setups, the upstream and the downstream configuration (figure 1), have been investigated. Both the MFM and the VFM measurements provide evidence that the Gilibrator can act like a "leak", in the sense, that water vapor will be added to the calibration air under previously described circumstances (4.1). This complication can be avoided completely, by choosing the downstream over the upstream configuration. However the downstream configuration exposes the Gilibrator to some overpressure, which is equal to the pressure drop across the FM (see Figure 1). Hence the pressure drop across the FM has to be smaller than the specified limit for the overpressure of the Gilibrator (**number from Sensidyne**). An appropriately specified pressure release valve could provide a relatively cheap, but efficient safety feature.

Pressure, temperature, and water vapor measurement

In many cases, the 1% accuracy of the Gilibrator can only be achieved, if additional parameters are measured. Section 2 explains in detail which parameters have to be recorded for the various cases. Depending on the particular situation different parameters such as pressure, temperature, and water vapor pressure have to be measured. Six different cases can be distinguished. Please find in appendix 2 a list of these cases with a reference to the appropriate formula in the analysis section. The only case which does not require any parameters beyond the flow measurements is the calibration of a VFM in the downstream configuration with upstream pressure as reference pressure. For all other cases at least one parameter besides the flow rates has to be recorded.

Error analysis showed that, if pressure and temperature probes are accurate to within 0.5% of the reading, the total calibration uncertainty increases from 1% due to the Gilibrator to 1.2%. It has also been shown that the vapor pressure measurement, although not necessarily negligible, is not critical in terms of accuracy. Many reasonably priced pressure and temperature probes meet those requirements. However even cheaper humidity sensors require an investment of several hundred dollars. This expense is not necessary, if the downstream configuration is feasible.

References

- Rogers, R.R., M.K Yau, A Short Course in Cloud Physics, 3rd ed., Pergamon Press, Oxford, 1989, p. 16
Gerthsen, C., Kneser, H.O., Vogel, H., Physik, Springer Verlag, Berlin, 16th edition, 1989
Kneubuehl, F.K., Repetitorium der Physik, Teubner, Stuttgart 1988, p. 518

Appendix 1 Data Tables

Mass Flow Measurement - Downstream Configuration

Q_{MFM} [slm]	3.816	7.204	11.06	14.39	19.75
$Q_{m,Gil}$ [slm]	3.892	7.347	11.25	14.61	20.09
RD [%]	-2.0	-1.9	-1.6	-1.5	-1.7
σ [%]	5.3	3.0	2.1	1.7	1.4

Table 1: Mass flow rates measured by MFM and Gilibrator in the downstream configuration. $Q_{m,Gil}$ has been calculated according to (17). The relative difference RD is defined as $(Q_{MFM} - Q_{m,Gil}) / Q_{m,Gil}$. Hence a negative sign indicates, that the Gilibrator measures a larger flow than the MFM. The standard deviation σ represents the expected statistical error due to the combined uncertainties of all measurement devices (27). The relatively large error for small flow rates is due to the constant uncertainty of 0.2 slm over the whole measurement range. Hence at 3.8 slm this induces an error of 5.3%.

Mass Flow Measurement - Upstream Configuration - without Vapor Correction

Q_{MFM} [slm]	4.016	8.04	11.87	15.94	18.76	19.66
$Q_{m,Gil}$ [slm]	4.111	8.263	12.19	16.28	19.28	20.13
RD [%]	-2.3	-2.7	-2.6	-2.1	-2.7	-2.3
σ [%]	5.1	2.7	2.0	1.7	1.5	1.4

Table 2: Mass flow rates measured by MFM and Gilibrator in the upstream configuration. $Q_{m,Gil}$ has been calculated according to (18) ignoring the vapor correction factor. The relative difference RD is defined as $(Q_{MFM} - Q_{m,Gil}) / Q_{m,Gil}$. Hence a negative sign indicates, that the Gilibrator measures a larger flow than the MFM. The standard deviation σ represents the expected statistical error due to the combined uncertainties of all measurement devices (27).

Mass Flow Measurement - Upstream Configuration - Vapor Correction Included

Q_{MFM} [slm]	4.016	8.04	11.87	15.94	18.76	19.66
$Q_{m,Gil}$ [slm]	4.024	8.134	12.05	16.14	19.15	20.01
RD [%]	-0.2	-1.2	-1.5	-1.3	-2.1	-1.7
σ [%]	5.1	2.7	2.0	1.7	1.5	1.4

Table 3: Mass flow rates measured by MFM and Gilibrator in the upstream configuration. $Q_{m,Gil}$ has been calculated according to (18) including the vapor correction factor. The relative difference RD is defined as $(Q_{MFM} - Q_{m,Gil}) / Q_{m,Gil}$. Hence a negative sign indicates, that the Gilibrator measures a larger flow than the MFM. The standard deviation σ represents the expected statistical error due to the combined uncertainties of all measurement devices (27).

Volumetric Flow Measurement - Downstream Configuration

Q_{VFM} [l/min]	0.20	0.40	0.60	0.80	0.90	0.92
$Q_{v,Gil}$ [l/min]	0.196	0.393	0.586	0.774	0.880	0.903
RD [%]	1.8	1.8	2.3	3.3	2.3	1.8
σ [%]	7.2	4.7	3.8	3.4	3.3	3.3

Table 4: Volumetric flow rates measured by VFM and Gilibrator in the downstream configuration. $Q_{v,Gil}$ has been calculated according to (1b). The relative difference RD is defined as $(Q_{VFM} - Q_{v,Gil}) / Q_{v,Gil}$. Hence a positive sign indicates, that the Gilibrator measures less flow than the VFM. The standard deviation σ represents the expected statistical error due to the combined uncertainties of all measurement devices (26).

Volumetric Flow Measurement - Upstream Configuration

Q_{VFM} [l/min]	0.17	0.36	0.55	0.75	0.95
$Q_{v,Gil}$ [l/min]	0.174	0.360	0.546	0.745	0.949
RD [%]	-2.1	0.1	0.8	0.7	0.1
σ [%]	7.8	4.9	4.0	3.5	3.2

Table 5: Volumetric flow rates measured by VFM and Gibrator in the upstream configuration. $Q_{v,Gil}$ has been calculated according to (11a) ignoring the vapor effect (no vapor content data were available). The relative difference RD is defined as $(Q_{v,FM} - Q_{v,Gil})/Q_{v,Gil}$. Hence a positive sign indicates, that the Gibrator measures less flow than the VFM. The standard deviation σ represents the expected statistical error due to the combined uncertainties of all measurement devices (26).

Appendix 2 Guidelines for Flow Meter Calibration

This section describes in detail the experimental procedure and the data analysis required for calibration of a FM with the Gilibrator. Data presented in section 6.1. will be used to give an example for the data analysis required for a calibration.

Overview of conversion formulas for the Gilibrator flow

The data analysis section presented six different formulas for the conversion of the Gilibrator flow rate into a value which should be indicated by the FM. The following contains a listing of the various cases and a reference to the appropriate formula.

MFM

- downstream configuration (17)
- upstream configuration (18)

VFM

- downstream configuration
 - downstream pressure as reference pressure (1b)
 - upstream pressure as reference pressure (1a)
- upstream configuration
 - downstream pressure as reference pressure (11a)
 - upstream pressure as reference pressure (11b)

Step-by-step procedure for calibration of flow meter

	ACTION	METHOD or REASON
1)	Adjust zero offset of FM	Prevents unwanted reduction of measurement range of FM
2)	Perform steps 1 through 6 as described in section 1.2	
3)	Convert the flow rates indicated by the Gilibrator into the values that should be indicated by the FM	Use equations (1a), (1b), (11a), (11b), (17), and (18) as outlined below
4)	Determine the slope and intercept of the calibration curve	The output signal of most FMs depends linearly on the flow rate. Use the FM readings as x coordinates and the converted Gilibrator values as y coordinates.

Accuracy of calibration

The accuracy of the flow rate σ_Q can be estimated by combining the effects of the uncertainty of the calibration σ_{cal} (24) and the repeatability R of the FM.

The repeatability is a measure of the reproducibility of a measurement. Switching a FM on and off while exposed to the same flow conditions will produce different readings. The less scattered those readings are, the smaller the repeatability.

$$\sigma_Q = \sqrt{\sigma_{cal}^2 + R^2} \quad (I)$$

Calibration example

Based on the data presented in appendix 1 table 1 the following calibration expression can be derived.

$$Q_{actual} = 0.015 + 1.016 Q_{MFM} \quad (II)$$

where the flow rate indicated by the MFM is in the same units as the actual flow rate Q_{actual} (here: slm). The figure below shows the five data points statistically scattered around the calibration line.

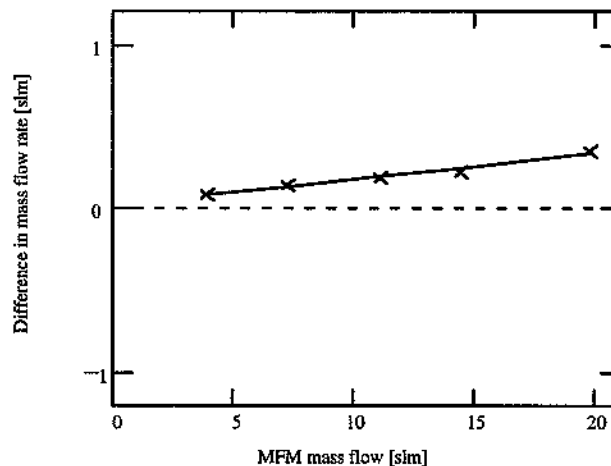

The accuracy of the flow rate determined by (II) can be estimated by (I). The repeatability of the MFM is 0.5 % of full scale and the accuracy of the converted Gilibrator flow rate is 1.0% (24). Hence the relative accuracy of the actual flow rate Q_{actual} is given by

$$\Delta Q_{actual} = \sqrt{0.01^2 + \frac{0.005 \cdot 20 \cdot slm}{Q_{MFM}}} \leq 1.1\% \quad \text{of full scale of the MFM (here 20slm). For a}$$

Q_{MFM} of 10slm, which is 50% of full scale, the relative uncertainty of the actual flow rate ΔQ_{actual} is 1.4% of the reading and hence 0.7% of full scale, which is better than the manufacturer guaranteed accuracy of 1% of full scale.

The final result of a calibration with the Gilibrator is expressed by the slope (here 1.016) and the intercept of the calibration curve (here 0.015 slm) and by the accuracy of the calibration (here better than 1.1% of full scale of the MFM).