

# LFS-113 LOW FLOW AIR SAMPLING PUMP

## OPERATION MANUAL

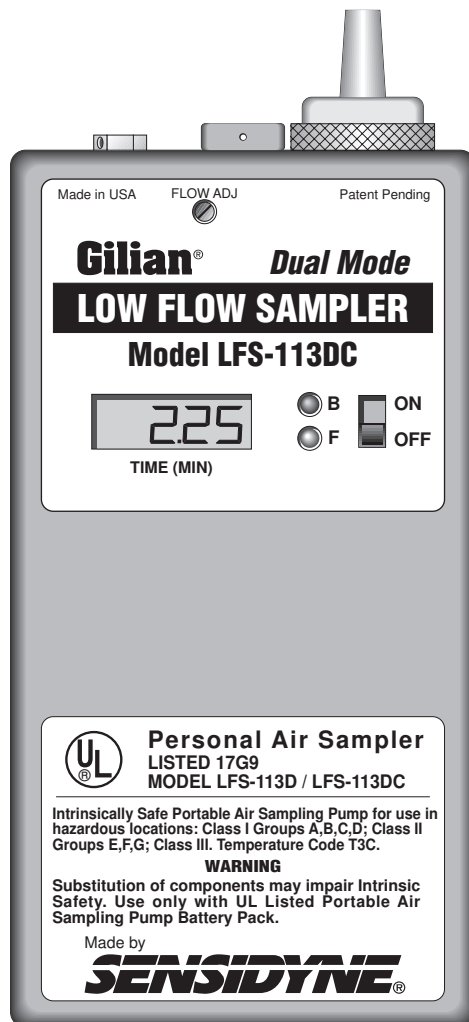

**SENSIDYNE®**

1000 112th Circle N, Suite 100 • St. Petersburg, Florida 33716 USA  
(800) 451-9444 • (727) 530-3602 • (727) 539-0550 [FAX] • [www.sensidyne.com](http://www.sensidyne.com)

**REF F-PRO-1725 (G)**



# LFS-113 LOW FLOW AIR SAMPLING PUMP

## OPERATION MANUAL

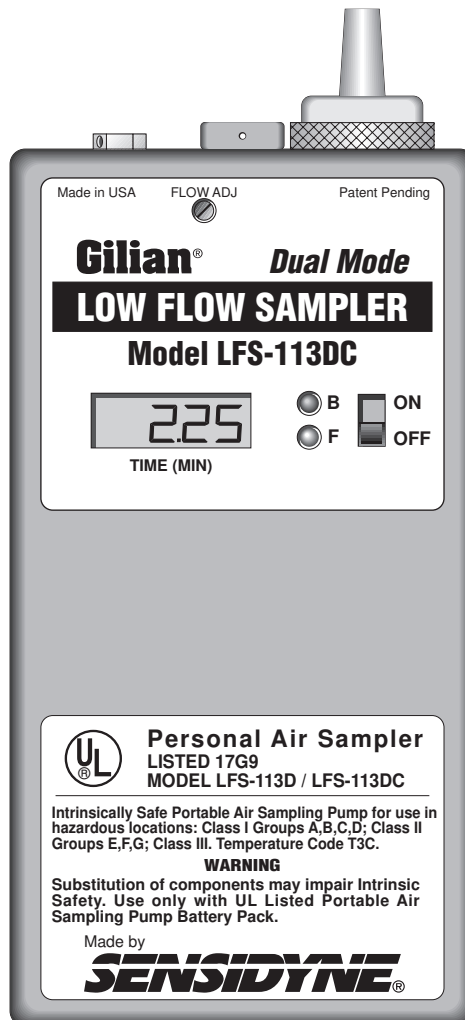

**PROPRIETARY NOTICE**

This manual was prepared exclusively for the owner of the Sensidyne LFS-113 Low Flow Air Sampling Pump. The material within this manual is proprietary information and is to be used only to understand, operate, and service the instrument. By receiving this document, the recipient agrees that neither this document nor the information disclosed within nor any part thereof shall be reproduced or transferred, physically, electronically or in any other form, or used or disclosed to others for manufacturing or for any other purpose except as specifically authorized in writing by Sensidyne, LP.

**COPYRIGHT NOTICE**

© 2003, © 2008 Sensidyne, LP All Rights Reserved. No part of this document may be reproduced, transmitted, transcribed, stored in a retrieval system, or translated into any language in any form by any means without the prior written permission of Sensidyne, LP.

**TRADEMARK NOTICE**

Sensidyne, the Sensidyne logo, Gilian, and the Gilian logo are registered trademarks. These trademarks are protected through use and registration in the United States. The trademarks and servicemarks used in this document are the property of their respective companies and are used only for informational and explanatory purposes.

**DISCLAIMER**

**THE SELLER ASSUMES NO RESPONSIBILITY WHATSOEVER, TO ANY PARTY WHOSOEVER, FOR ANY PROPERTY DAMAGE, PERSONAL INJURY, OR DEATH RECEIVED BY OR RESULTING FROM, IN WHOLE, OR IN PART, THE IMPROPER USE, INSTALLATION, OR STORAGE OF THIS PRODUCT BY THE USER, PERSON, FIRM, ENTITY, CORPORATION OR PARTY NOT ADHERING TO THE INSTRUCTIONS AND WARNINGS IN THIS MANUAL, OR OTHERWISE PROVIDED BY THE SELLER OR FROM NOT ADHERING TO ALL FEDERAL, STATE, AND LOCAL ENVIRONMENTAL AND OCCUPATIONAL HEALTH AND SAFETY LAWS AND REGULATIONS.**

**THE SELLER SHALL NOT BE LIABLE FOR DIRECT, INDIRECT, CONSEQUENTIAL, INCIDENTAL OR OTHER DAMAGES RESULTING FROM THE SALE AND USE OF ANY GOODS AND SELLERS' LIABILITY HEREUNDER SHALL BE LIMITED TO REPAIR OR REPLACEMENT OF ANY GOODS FOUND DEFECTIVE. THIS WARRANTY IS IN LIEU OF ALL OTHER WARRANTIES, EXPRESSED OR IMPLIED, INCLUDING BUT NOT LIMITED TO THE IMPLIED WARRANTIES OF MERCHANTABILITY AND FITNESS FOR USE OR FOR A PARTICULAR PURPOSE WHICH ARE EXPRESSLY DISCLAIMED.**

# TABLE OF CONTENTS

- **PREFACE**
- Notices ..... 4
- **WARNINGS** ..... 6
  
- SECTION ONE: INTRODUCTION**
- Components ..... 7
  
- SECTION TWO: PUMP OPERATION**
- 2.1 Equipment Set-Up ..... 10
- 2.2 Field Calibration/Flow Verification ..... 11
- 2.3 Taking A Sample ..... 14
  
- SECTION THREE: MAINTENANCE**
- 3.1 Battery Maintenance ..... 15
- 3.2 Filter Maintenance ..... 15
  
- SECTION FOUR: APPENDICES**
- Appendix A: Parts List ..... 16
- Appendix B: Specifications ..... 17
- Appendix C: Service ..... 18
  
- LIST OF FIGURES**
- 1.1 LFS-113 Air Sampling Pump: Front View ..... 8
- 1.2 LFS-113 Air Sampling Pump: Rear View ..... 9
  
- 2.1 Field Calibration Equipment Set-Up ..... 10
- 2.2 Field Calibration: Constant Flow ..... 12
- 2.3 Field Calibration: Multi-Flow ..... 13
- 2.4 Sampling ..... 14



# WARNINGS

## **READ AND UNDERSTAND ALL WARNINGS AND INSTRUCTIONS BEFORE USE**

Failure to read, understand, and comply with ALL accompanying literature, product labels, and warnings could result in property damage, severe personal injury, or death.

Read and understand ALL applicable environmental health and safety laws and regulations. Ensure complete compliance with ALL applicable laws and regulations before and during use of this product.

DO NOT remove, cover, or alter any label or tag on this product, its accessories, or related products.

UNDER NO CIRCUMSTANCES should this product be used except by qualified, trained, technically competent personnel.

DO NOT operate this product should it malfunction, require repair, or have a cracked or broken case. DO NOT repair or modify, except as specified in Operation Manual. No user serviceable parts located within case. Service to be performed by Sensidyne Authorized Service Departments only.

Use ONLY specified Sensidyne parts when performing maintenance procedures described in this manual. Intrinsic safety certifications become void by substitution of components, unauthorized repair or alteration.

This product is intended for both indoor and outdoor use when protected from splashed or wind blown liquids. The unit is not waterproof so NEVER submerge the unit in water. Pump failure or faulting may result.

Possible static hazard. Do not rub with dry cloth.

DO NOT charge battery in an explosive atmosphere.

This product uses rechargeable Nickel-Cadmium batteries. ALWAYS fully charge before use. Use only battery pack and chargers specified in Operation Manual. DO NOT insert any foreign objects into contact slot. Shorting contacts will blow protective fuse.

If the equipment is likely to come into contact with aggressive substances, then it is the responsibility of the user to take suitable precautions that prevent it from being adversely affected, thus ensuring that the type of protection is not compromised. Examples of aggressive substances are acidic liquids or gases that may attack metals, or solvents that may affect polymeric materials. Examples of suitable precautions are regular checks as part of routine inspections or establishing from material data sheets that it is resistant to specific chemicals.

DO NOT operate with a dirty or blocked inlet filter or kinked tubing. Pump failure or faulting may result.

Caution: Both charger and battery become warm during charging.

If further translation is required, please contact Schauenburg Electronic Technologies GmbH, the Sensidyne EU Authorized Representative.

# SECTION ONE

## INTRODUCTION

- **COMPONENTS**

- **See Figures 1.1 and 1.2**

- (1) Inlet Boss  
The Inlet Boss is located on the filter housing and provides a built-in means of attaching tubing for suction sampling.
- (2) Air Inlet Pump Filter  
A 10 Micron Nylon Air Inlet Pump Filter protects the pump assembly from dirt.
- (3) Flow Adjustment (requires slotted screwdriver).
- (4) Battery Check  
This green LED (B) indicates that sufficient battery power is available to run the pump for an 8 hour period under normal load conditions.
- (5) On/Off Switch
- (6) Fault Indicator  
This red LED (F) indicates a flow fault due to excessive pressure or insufficient battery voltage to maintain flow.
- (7) Clock Display (DC Model only)  
The Clock Display shows the continuous run-time (in minutes, to two decimal places), and will lock-in the sample time upon fault indication. The time will reset to zero when the power switch is turned OFF and then back ON again.
- (8) Outlet Port  
The Outlet Port provides a receptacle for the discharge (bag sampling) boss accessory. The cap screw prevents dirt from entering the Outlet Port when not in use.
- (9) Discharge (Bag Sampling) Boss  
This is an accessory which, when installed into the Outlet Port, provides a means for filling air sampling bags.
- (11) Charging Jack  
The Charging Jack receptacle is used to connect a charger for recharging the internal battery pack.
- (12) Belt Clip
- (13) Rechargeable Battery Pack
- (14) Tube Breaker Assembly.
- (15) Mode Indicator  
The Mode Indicator visually confirms the sampling mode selected (via a Black/White indicator)
- (16) Mode Selector  
The Mode Selector is used to change the sampling mode. The selector is used for unlocking, indexing, and re-locking the mode selector valve while changing from Constant Flow Mode to Constant Pressure (Multi-Flow) Mode.
- (17) Hex Key

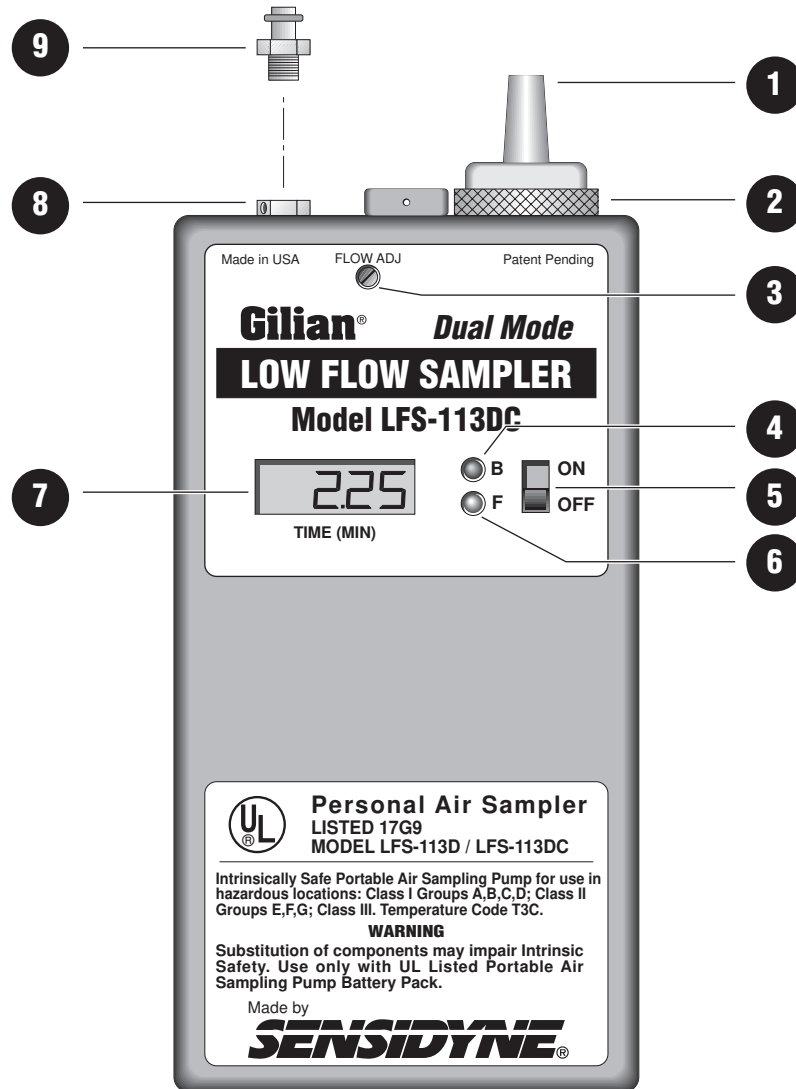

**Figure 1.1**  
**LFS-113 Air Sampling Pump: Front View**

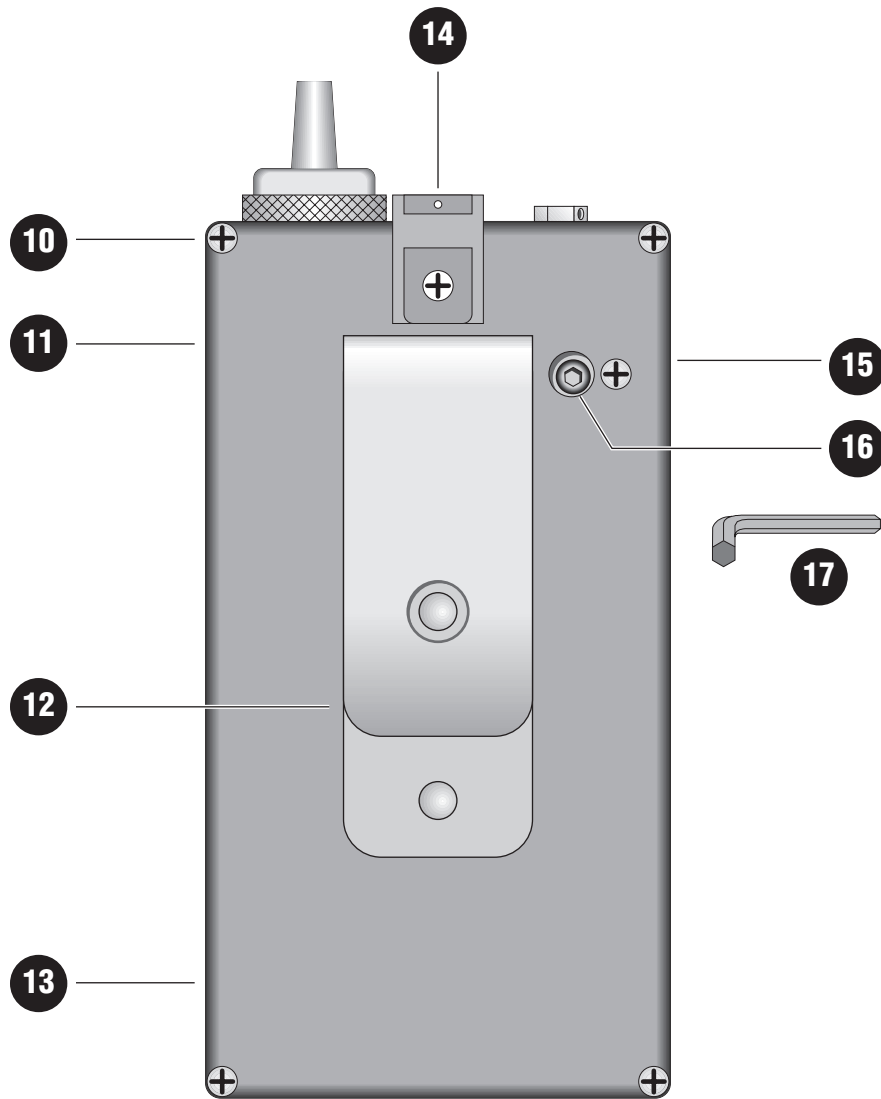

**Figure 1.2**  
**LFS-113 Air Sampling Pump: Rear View**

# SECTION TWO

## PUMP OPERATION

### 2.1 Equipment Set-Up

- 1) Use an LFS-113 pump with a fully charged battery pack.
- 2) Attach tubing to the pump.
- 3) Connect a constant flow [3A] or Multi-Flow [3B] collection device to the tubing.
- 4) Connect the tubing from the collection device to a Gilibrator 2.
- 5) Set up and turn on the Gilibrator 2.

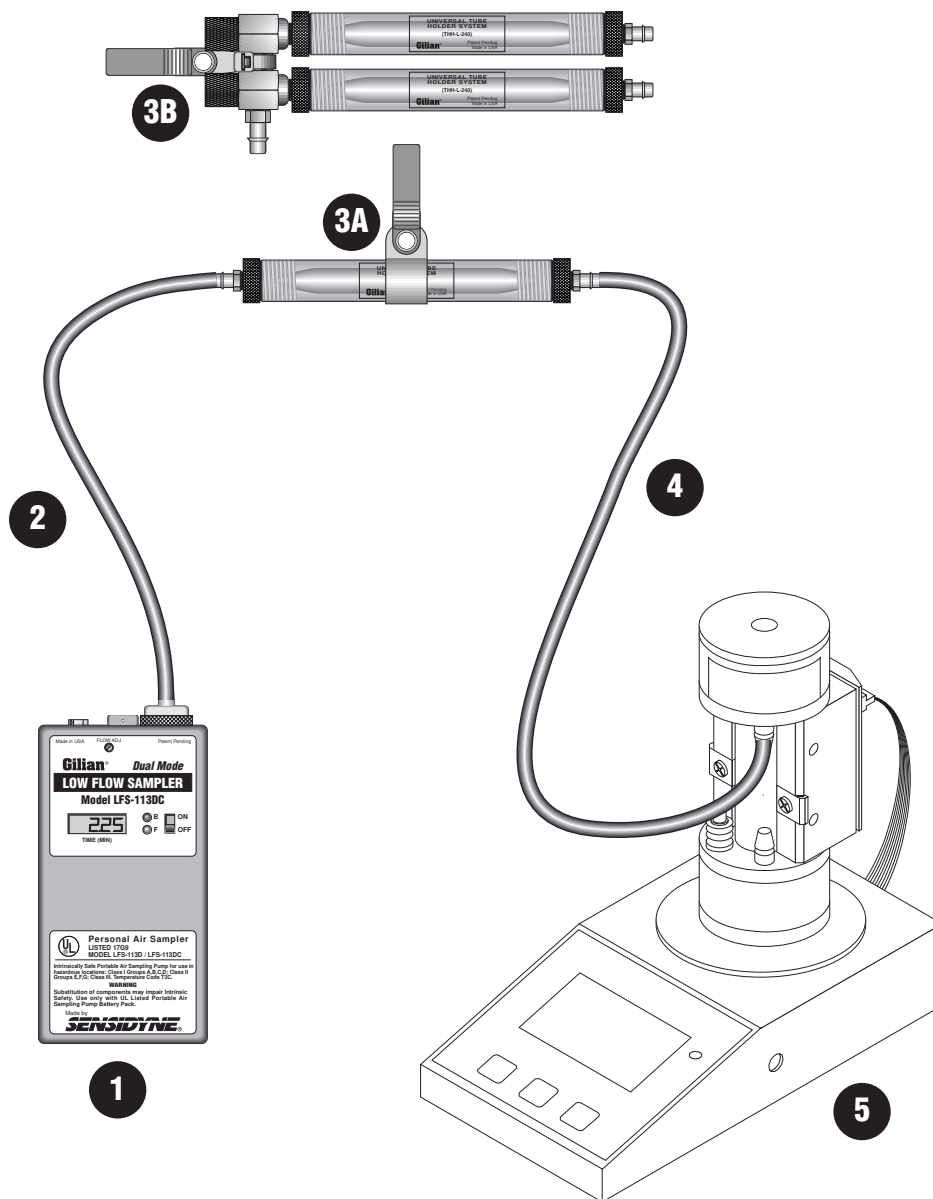

**Figure 2.1**  
**Field Calibration Equipment Set-Up**

## 2.2 Field Calibration/Flow Verification

Field calibration (flow rate verification) must be performed before sampling and when setting the flow rate.

- See **Figure 2.2 for Constant Flow**

- See **Figure 2.3 for Multi-Flow**

- 1) Insert the hex key [1] into the hex head screw on the pump.
- 2) Turn the key counterclockwise [2] to change the mode.
- 3) Continue turn the key until the mode indicator shows black for constant flow [Fig. 2.2, #3] or white for multi-flow [Fig. 2.3, #3].
- 4) Turn the key clockwise [4] to lock your selection into place.

- 5) Turn on the pump using a pointed instrument such as ball point pen [5].

- 6) Make sure the Gilibrator 2 is on and working.

- 7) Set the pump flow rate as follows:

**Constant Flow:** Use a slotted screwdriver to make flow adjustments on the pump itself [Fig. 2.2, #6].

**Multi-Flow:** Use a slotted screwdriver to make individual flow adjustments on the sampling device [Fig. 2.3, #6].

- 8) When desired flow rate has been reached, turn off pump and Gilibrator 2. The pump is now ready for sampling.

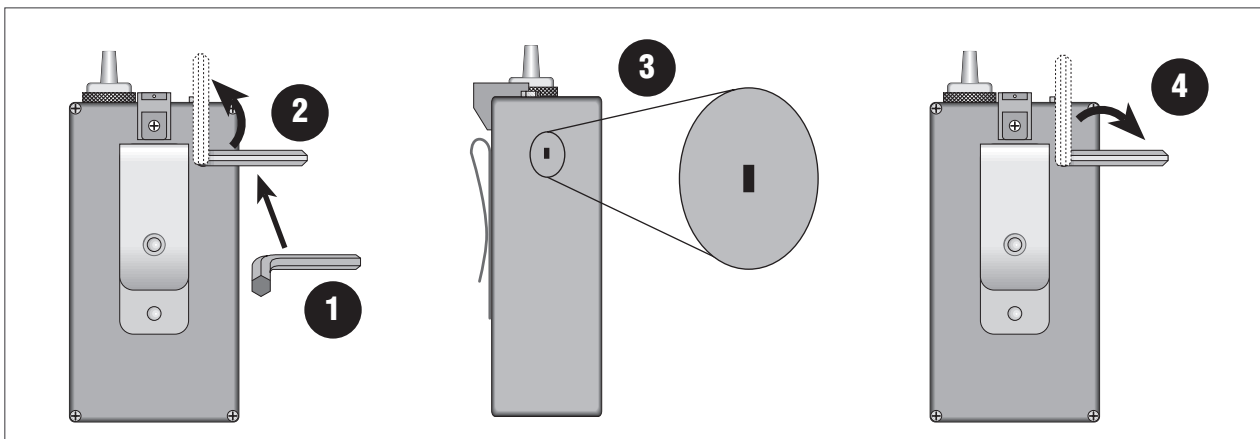
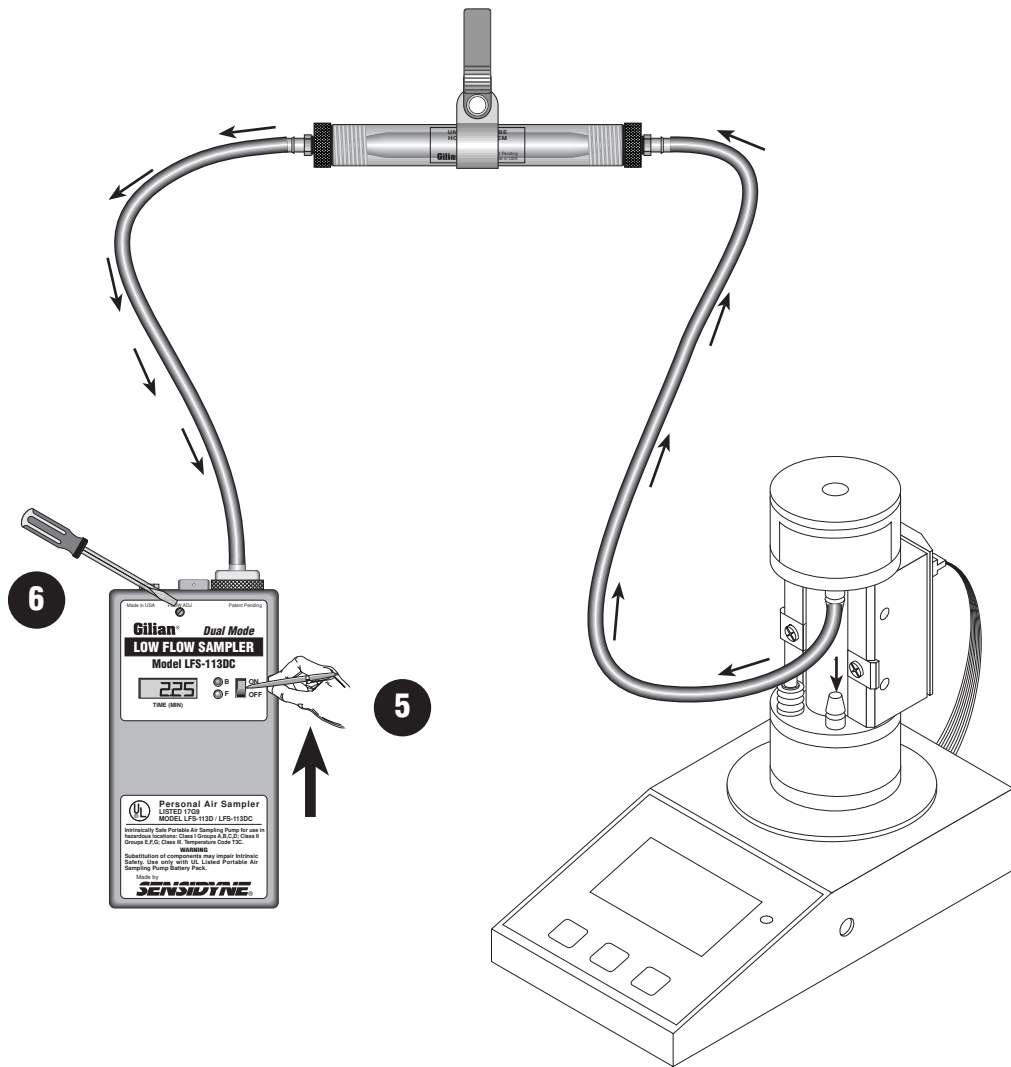

**Figure 2.2**  
**Field Calibration: Constant Flow**

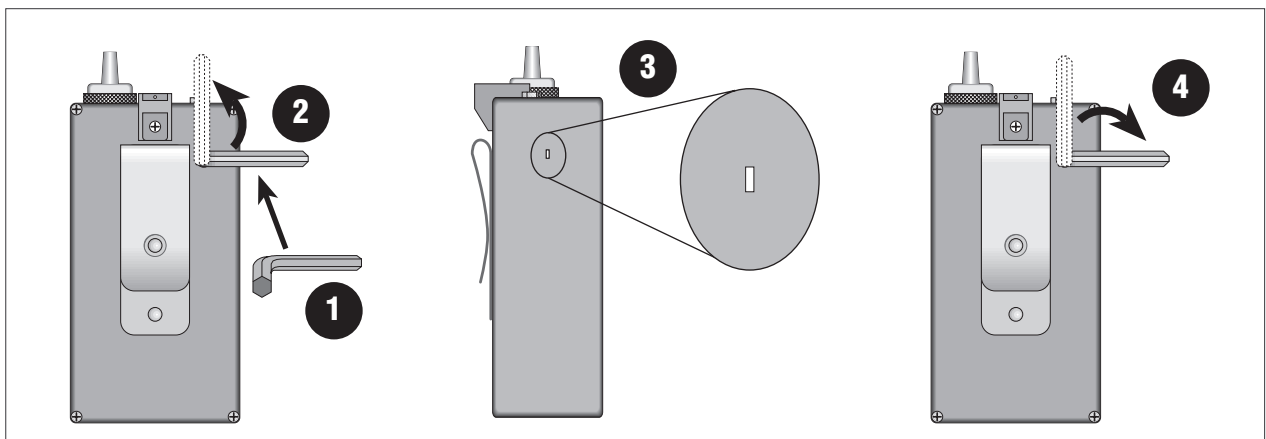
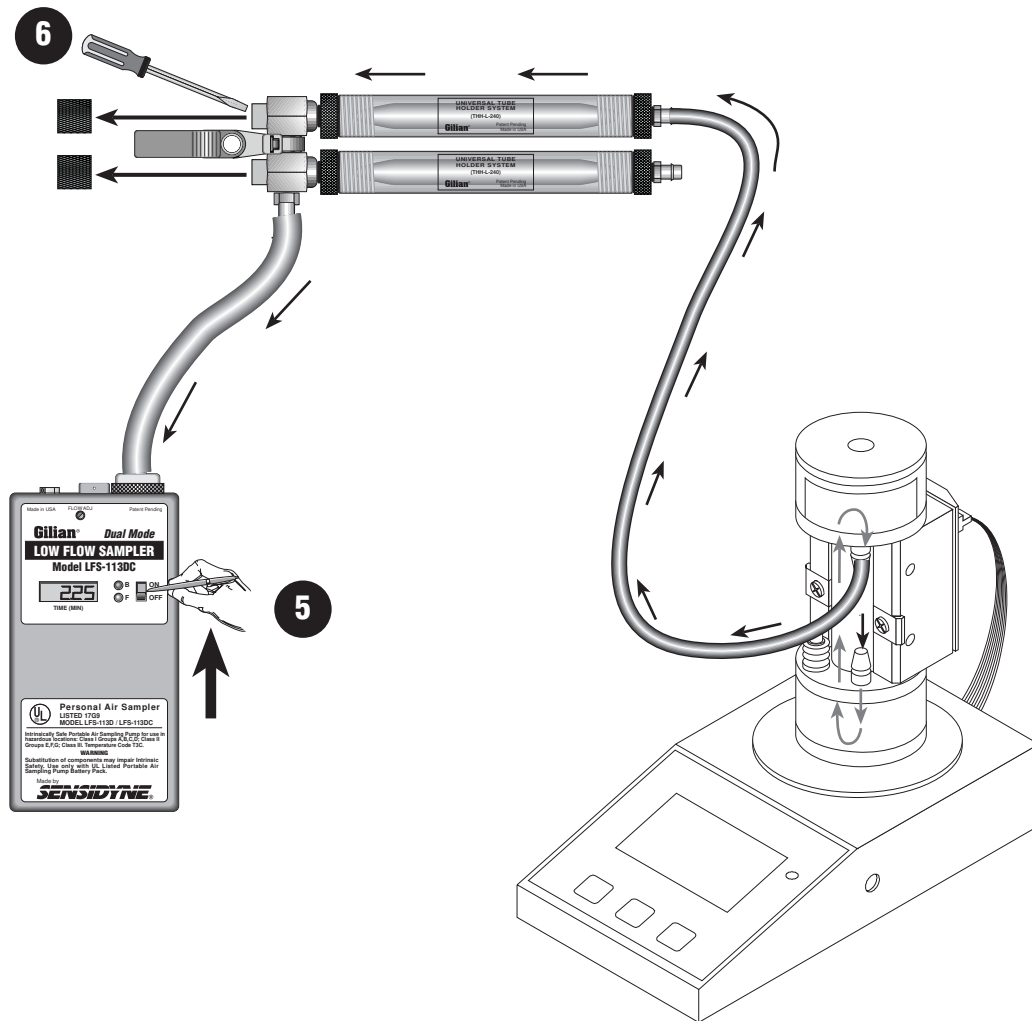

**Figure 2.3**  
**Field Calibration: Multi-Flow**

### 2.3 Taking A Sample

- 1) Use a pointed instrument such as a ball point pen to turn on the pump.
- 2) Place the pump, tubing and sampling device on the worker as shown in Figure 2.4.
- 3) When sampling is completed use a pointed instrument such as a ball point pen to turn off the pump. Record the sample data.

#### Note for Clock Models

When the pump is shut off after a sample run, the accumulated run time minutes (to the nearest 0.01 minute) are displayed. To calculate totaled air volume sampled, use the following formula:

$$\text{Total Air Volume (Liters)} = \text{Air Flow Rate (cc/min)} \times \text{Sample Time (minutes)} \div 1000 \text{ cc/Liter}$$



**Figure 2.4**  
**Sampling**

# SECTION THREE MAINTENANCE

## 3.1 Battery Maintenance

---

### NOTE

*Do not charge battery pack while in an explosive atmosphere.*

---

The LFS-113 pump uses rechargeable Nickel-Cadmium batteries that must be fully charged and properly maintained for maximum run time. The battery pack is rated at 4.8 Volts (720 mAh).

Make certain charger plug is fully inserted into jack on battery pack (see Figure 1.2, #11 for charger jack location).

---

### CAUTIONS & NOTES

*Both charger and battery pack become warm during charging.*

*Do not short battery terminals. Shorting will blow internal fuse.*

---

#### • Memory Effect

Nickel-Cadmium batteries will develop reduced capacity when they are not fully discharged and then fully recharged after sampling. Memory effect takes time to develop and can usually be eliminated by performing two complete discharge/recharge cycles on the pump.

#### • Leakage Current

Nickel-Cadmium batteries always have a small internal leakage current. If the battery pack has been removed from the charger for more than two days without use, it will require additional charging to restore it to full capacity. This process can be repeated two or three times without causing signs of memory effect.

Battery pack has an estimated life of 300–500 charge/discharge cycles, depending on use. Table below shows estimated battery life based on usage level.

Pump Usage	Weekly Use	Est. Battery Life
High .....	40-60 hrs .....	1.0-1.5 yrs
Medium .....	20-39 hrs .....	1.5-2.5 yrs
Low .....	< 20 hrs .....	2.5 yrs

#### • Chargers

##### Single Station Charger

A constant-rate single-station charger that is suitable for both overnight charging and weekend charging.

##### LFATR Multi-Station Charger

A dual rate charger offering five-station timed constant-rate charging that automatically defaults to trickle charge.

---

### NOTE

*Both chargers can be damaged by line transients and overvoltage. While not a common problem, long term reliability can be improved by use of a surge/overvoltage protector.*

---

## 3.2 Filter Maintenance

Under normal operating conditions, the pump filter should be changed after approximately six months or 250 hours of operation, or when needed. Failure to change the filter as it becomes dirty will decrease the pump's back pressure capability and performance envelope.

#### • See Figure 1.1, #1

Blow all dust and debris from around the Filter Housing. Grasp the knurled edge of the filter housing assembly and rotate counterclockwise. Check the new filter housing assembly to make sure that the sealing O-ring is present on the internal boss. Install the new Filter Housing Assembly onto the pump rotating the knurled edge clockwise. *Do Not Overtighten!*

# APPENDIX A

## PARTS LIST

### Accessories

<i>Part Number</i>	<i>Description</i>
200504 .....	Tubing, 1/8" ID x 1/16" W (10 ft)
200505 .....	Tubing, 1/8" ID x 1/16" W (3 ft)
800565-4 .....	Diagnostic Panel with Carrying Case (2–50cc, 20–200cc, 50–800cc)
800400 .....	Carrying Case (18" x 13" x 7")
800093 .....	Filter Assembly
800093-3 .....	Filter Assembly (pkg of 3)

### Spare Parts

<i>Part Number</i>	<i>Description</i>
400324 .....	5-Unit Charger, 120V
298-0005-01 .....	Single Unit Charger, 120V
800222 .....	Tool Kit
800685 .....	Air Boss Kit (required for bag sampling)
F-PRO-1725 .....	LFS-113 Manual

# APPENDIX B

## SPECIFICATIONS

Additional Features .....	Flow Fault indication LED Batt check LED Belt clip Dual filtration system Sorbent tube end breaker External flow adjust
Options .....	Elapsed timer clock module (DC models only): LCD display automatic instant-fault shutdown function RFI shielding
Dimensions .....	2.50" (W) x 1.38" (H) x 4.63" (L) 63.5 mm (W) x 34.9 mm (H) x 117.5 mm (L)
Weight .....	Main Unit: 12 oz (340 g)
Operating Range (Constant Flow Mode) ....	20–200 cc/min, back pressures to 25" H <sub>2</sub> O
Operating Range (Constant Pressure Mode)	1–350 cc/min, flows adjustable through a single or multiple tube flow controller.
Pressure Range .....	Backpressure up to 25" H <sub>2</sub> O.
Flow Control .....	± 5% of set point
Battery Type .....	Rechargeable Nickel-Cadmium battery pack
Battery Output .....	4.8 v, 500 mAh
Charging .....	Internal (external with adapter).
Operating Temperature .....	-20° to 45°C (-4°F to 113°F)
Storage Temperature .....	-40° to 45°C (-40°F to 113°F)
Charging Temperature .....	0° to 45°C (32°F to 113°F)
Safety Approvals: .....	UL Listed Intrinsically Safe for use in Class I Groups A, B, C, D, Class II Groups E, F, G; Class III Temperature Code T3C

# **APPENDIX C**

# **SERVICE**

## **Domestic Service**

**Sensidyne, LP**  
**1000 112th Circle N, Suite 100**  
**St. Petersburg, Florida 33716 USA**

**800-451-9444**  
**727-530-3602**

**727-539-0550 [Main fax]**  
**727-538-0671 [Service fax]**

**e-mail: [info@sensidyne.com](mailto:info@sensidyne.com)**  
**web: [www.sensidyne.com](http://www.sensidyne.com)**



**Manufactured by:**

**Sensidyne, LP  
1000 112th Circle N, Suite 100  
St. Petersburg, Florida 33716  
USA**

**800-451-9444 • 727-530-3602 • 727-539-0550 [fax]  
www.sensidyne.com • info@sensidyne.com**