

***SENSALERT* PLUS**

Remote Sensor Kits

Installation Manual

Document No. 360-0092-01
(Revision G)

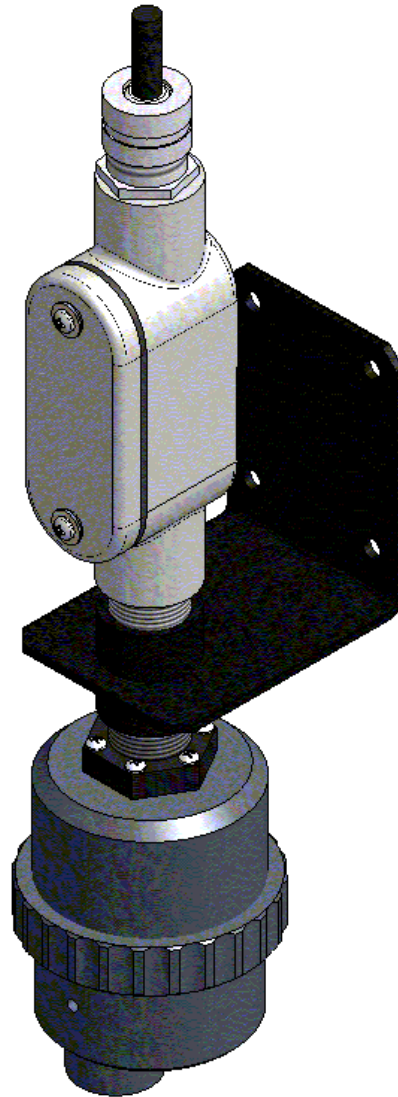

SENSIDYNE

Sensidyne, LP • 1000 112th Circle N, Suite 100
St. Petersburg, Florida 33716 USA

800-451-9444 • +1 727-530-3602 • +1 727-539-0550 [fax]
web: www.sensidyne.com • e-mail: info@sensidyne.com

REMOTE OPTIONS

P/N 821-0207-01
DIV 1 Intrinsically Safe,
DIV 2 and
NON-HAZARDOUS

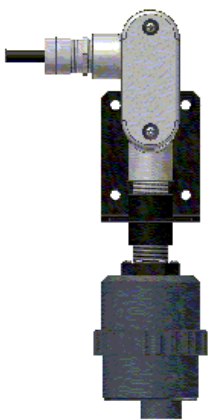

P/N 821-0207-02
DIV 1
EXPLOSION PROOF /
FLAME PROOF

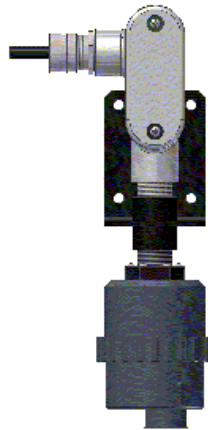
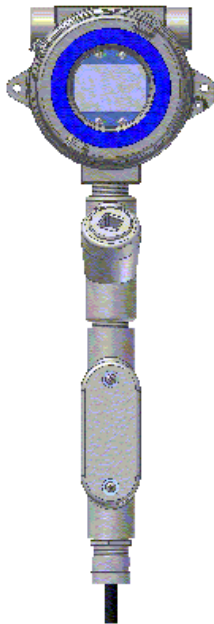

P/N 821-0207-03
-03 OPTION
INTERFACE SEPARATE

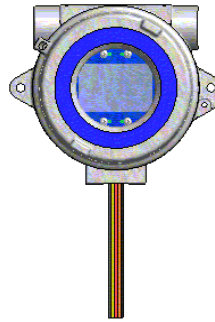

P/N 821-0207-04
-04 OPTION
DIV 1 Intrinsically Safe,
DIV 2 and
NON-HAZARDOUS,
with Wire Gland

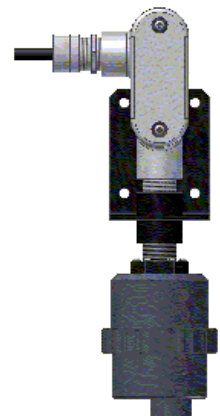

WARNINGS PAGE

WARNINGS

READ AND UNDERSTAND ALL WARNINGS BEFORE USE

Read and understand ALL warnings before using this product. Failure to read, understand, and comply with ALL warnings could result in property damage, severe personal injury, or death.

Installation must be done in accordance with all local electrical codes. Follow standard grounding procedures when wiring the Remote Sensor Kit. All warnings and installation instructions should be read and understood as contained in the SensAlert Plus Universal Gas Transmitter User Manual (P/N 360-0087-02).

If retrofitting an existing SP52, SP5IS, SP5HD2, SP5HDI, or SP5XP Transmitter, it is recommended that the Transmitter be returned to Sensidyne for Interface removal or use caution in separating Interface and Condulet.

Sensor Interface Assembly must be mounted such that condensation and dust does not collect on the Sensor.

Read and understand ALL applicable federal, state, and local environmental health and safety laws and regulations, including OSHA. Ensure complete compliance with ALL applicable laws and regulations before and during use of this product.

The user/installer must understand the Hazardous Area Protection Concepts and Area Classifications applicable to their operation.

UNDER NO CIRCUMSTANCES should this product be used except by qualified, trained, technically competent personnel and not until the warnings, User Manual, labels, and other literature accompanying this product have been read and understood.

Failure to read and understand the User Manual may result in preventable severe personal injury or death.

DO NOT remove, cover, or alter any label or tag on this product, its accessories, or related products.

DO NOT operate this product should it malfunction or require repair. Operation of a malfunctioning product, or a product requiring repair may result in serious personal injury or death.

DO NOT attempt to repair or modify instrument, except as specified in the Operation & Service Manual. If repair is needed, contact the Sensidyne Service Dept. to arrange for a Returned Material Authorization (RMA) (See Section in the SensAlert Plus Universal Gas Transmitter User Manual (**P/N 360-0087-02**) for details).

The SensAlert Plus Universal Gas Transmitter is an ambient air monitoring device. Restricting the access of ambient air to the sensor may result in less than optimal monitoring performance.

NOTES:

1. Following the instructions given in this manual and installation drawings contained in the SensAlert Plus manual (P/N: 360-0087-02) the Sensor Interface Assembly will remain an Intrinsically Safe approved device.
2. The sensor may be orientated from horizontal down to vertical. The surface of the sensor must be protected from moisture (condensation) and dust.

• **821-0207-01 Remote Sensor Kit for use with SensAlert Plus SP52, SP5IS, SP5HD2, SP5HDIS Models**

SensAlert Plus Remote Sensor Kit (P/N 821-0207-01) contains the following items
(Note: References in brackets refer to letter/number references in Figure 1):

Ref No.	Sensidyne.P/N	DESCRIPTION
[A-2, A-8].....	550-4003-01	Aluminum Condulet Nipple, 3/4 NPT (Qty 1)
[A-7]	522-0002-01	Junction Condulet with two 3/4 NPT openings
[A-3, A-7].....	522-0002-02	Cover, Condulet (Qty = 2) (Shown Assembled)
[A3, A-7].....	522-0002-03	Gasket, Neoprene, (Qty = 2) (Shown Assembled)
[A-3]	522-0002-04	Junction Condulet with two 90° 3/4 NPT openings
[A-4, A-6].....	7017291	Watertight Cable Entry / Cable Strain Relief (Qty = 2)
(Not shown)	205-0081-01	Splice 2 pos (Qty = 4)
[A-9]	380-0021-01	Bracket Weld Assembly (Black Anodized) (Qty 1)

Cable Specification: 18AWG x 4 Conductor (Shielded) uH/ft < 0.2, pf/ft < 60, Max length 100ft/30m
Cable to be Customer Supplied. Belden 27326AS or equivalent.

Installation

Refer to Figure 1 and install the Remote Sensor Kit as follows:

- 1) Fasten the Bracket [A-9] to the desired location. Sensor Interface Assembly must be mounted such that condensation and dust does not collect on the Sensor. Thread the wires from the Sensor Interface Assembly [A-10] through the Bracket [A-9] and Nipple [A-8], tighten to secure.
(Note: If you are using tools to tighten the Sensor Interface Assembly make certain you use them ONLY on the Aluminum hex nut which came attached to the top of the Sensor Interface Assembly.)
- 2.) Thread the wires from the Sensor Interface Assembly [A-8] into the lower opening of the Junction Condulet [A-7]. Tighten the the Junction Condulet [A-7] to the Nipple [A-8]
(Note: If you are using tools to tighten the Sensor Interface Assembly make certain you use them ONLY on the Aluminum hex nut which came attached to the top of the Sensor Interface Assembly.)
- 3) Thread the customer-supplied remote cable [A-5] through the Watertight Strain Relief [A-6].and tighten to secure remote cable.
- 4) Wire the remote cable to the interface using 4 of the Splices provided.
Wire accordingly (R = Red, B = Black, O = Orange, Y = Yellow).
Install the Condulet Gasket and Cover.)
- 5) Route and secure the customer-supplied remote cable [A-5] to the Transmitter Location [A-1].
- 6) Thread the wires from the Transmitter [A-1] through the Condulet Nipple [A-2] and install nipple into the Transmitter.
- 7) Thread the wires from the Transmitter through the Junction Condulet [A-3] and turn onto the Nipple
- 8) Install the Watertight Strain Relief [A-4] and remote cable into the Junction Condulet [A-3].
- 9) Wire the remote cable to the wires from the Transmitter [A-1] using 5 of the Splices provided. Wire accordingly (R = Red, B = Black, O = Orange, Y = Yellow). Connect the shield wire to the Gray wire from the Transmitter [A-1]. Install the condulet gasket and cover.
- 10) You may mount and wire the transmitter to a power source at this time (leave transmitter unpowered).
- 11) Follow the instructions in Section 2.5 of the Transmitter User Manual to power up the transmitter

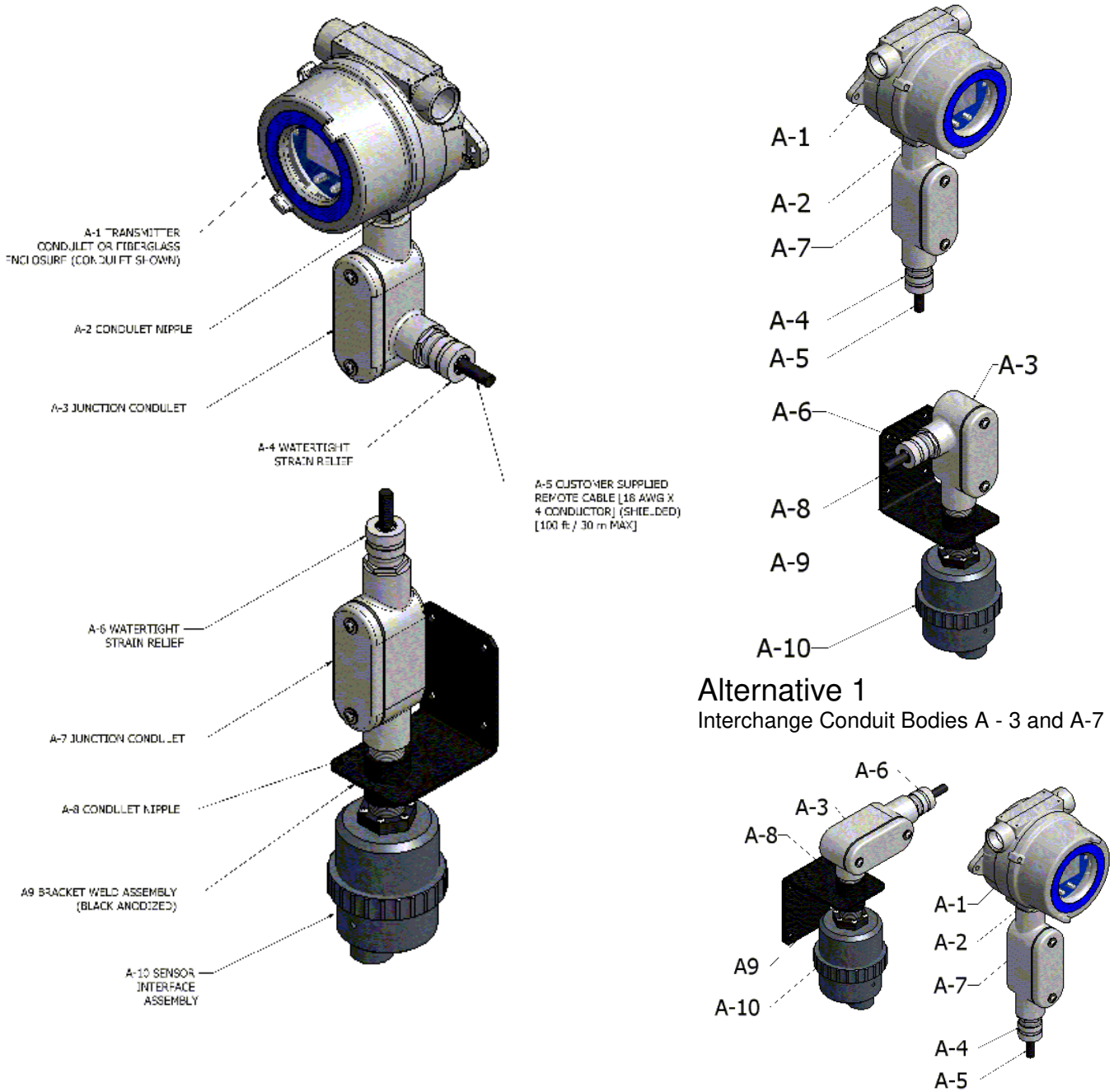

Figure 1
Remote Sensor Kit Installation
(DIV 1 Intrinsically Safe, DIV 2 and Non-Hazardous Transmitters)

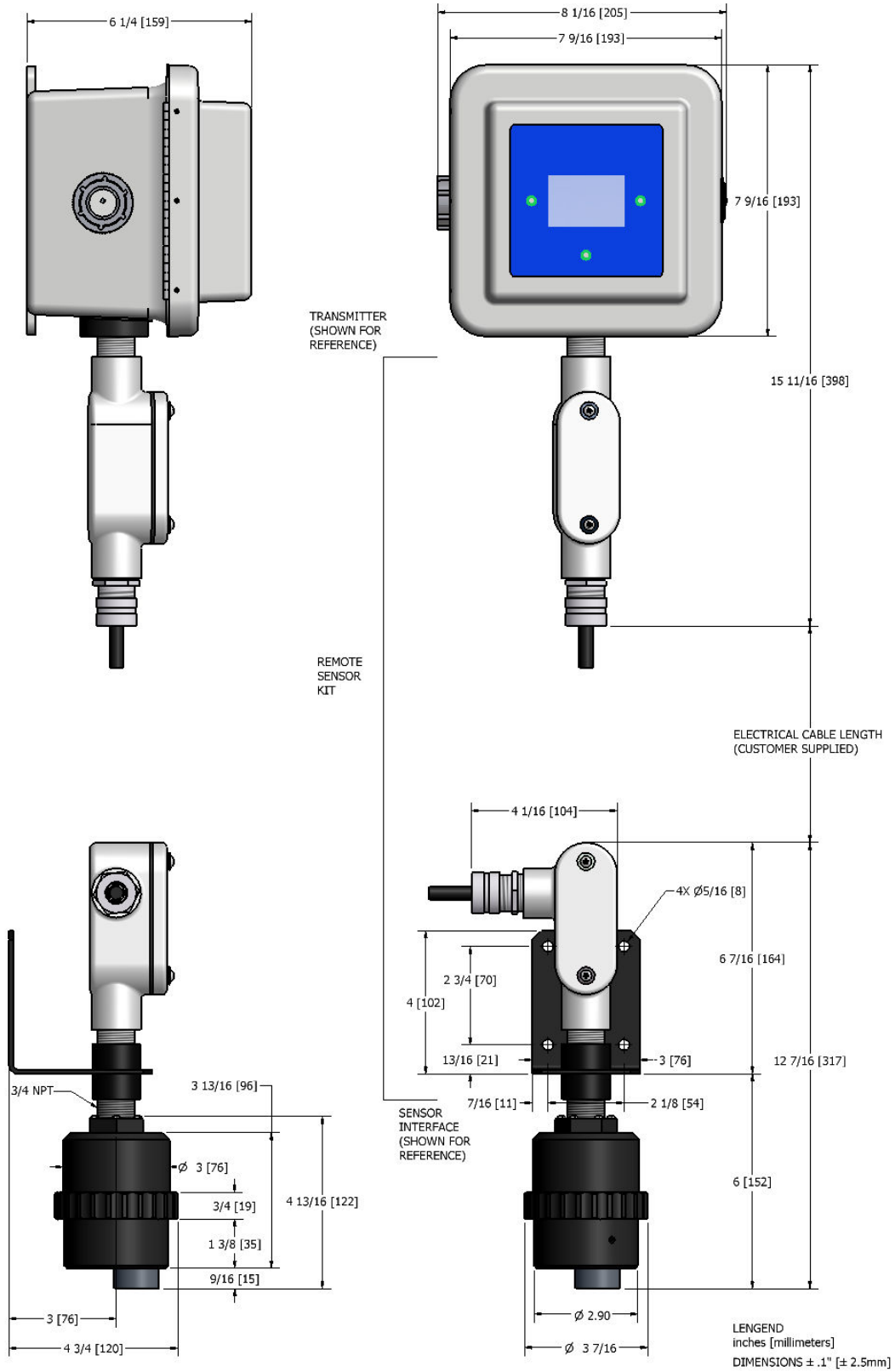

Figure 2
FIBERGLASS TRANSMITTER ENCLOSURE (SP52 & SP5IS MODELS) REMOTE DIMENSIONS

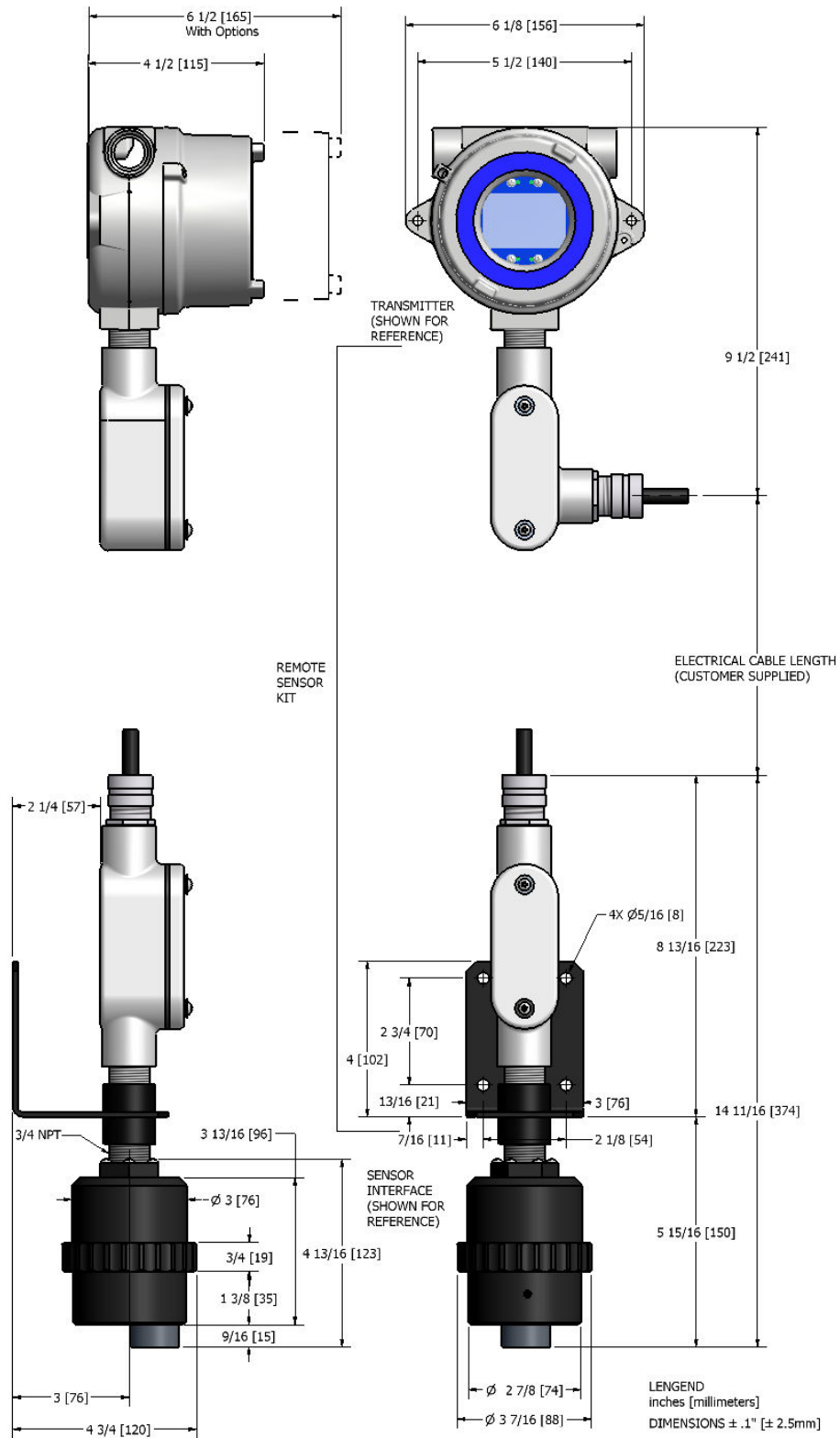

FIGURE 3
ALUMINUM TRANSMITTER ENCLOSURE (SP5HD2 & SP5HDIS MODELS) REMOTE DIMENSIONS

• 821-0207-02 Remote Sensor Kit

for use with SensAlert Plus SP5XP Models

SensAlert Plus Remote Sensor Kit (P/N 821-0207-02) contains the following items
(Note: References in brackets refer to letter/number references in Figure 4):

Ref No.	Sensidyne.P/N	DESCRIPTION
[B-5]	522-0002-01	Junction Condulet with two $\frac{3}{4}$ NPT openings
[B-5, B-9].....	522-0002-02	Cover, Condulet (Qty = 2) (Shown Assembled)
[B-5, B-9].....	522-0002-03	Gasket, Neoprene, (Qty = 2) (Shown Assembled)
[B-9]	522-0002-04	Junction Condulet with two 90° $\frac{3}{4}$ NPT openings
[B-2, B-4, B-10].....	550-4003-01	Aluminum Condulet Nipple, $\frac{3}{4}$ NPT (Qty = 3)
[B-6, B-8].....	7017291	Watertight Cable Entry / Cable Strain Relief (Qty = 2)
(Not shown)	205-0081-02	Splice 2 pos (Qty = 9)
[B-11]	380-0021-01	Bracket Weld Assembly (Black Anodized) (Qty 1)

Conduit Seal Kit (Not shown) includes the following:

7017432	Seal – Conduit, female, $\frac{3}{4}$ NPT [B-3]
572-0005-01	Fiber Filler
7017229	Kwiko Cement

Cable Specification: 18AWG x 4 Conductor (Shielded) uH/ft < 0.2, pf/ft < 60, Max length 100ft/30m
Cable to be Customer Supplied. Belden 27326AS or equivalent.

Installation

Refer to Figure 4 and install the Remote Sensor Kit as follows:

- 1) Fasten the Bracket [B-11] to the desired location. Sensor Interface Assembly must be mounted such that condensation and dust does not collect on the Sensor. Thread the wires from the Sensor Interface Assembly [B-10] through the Bracket [B-11] and Locknut $\frac{3}{4}$ NPT [B-12] , Tighten the Locknut to secure. **DO NOT OVER TIGHTEN** (Note: If you are using tools to tighten the Sensor Interface Assembly make certain you use them ONLY on the Aluminum hex nut which came attached to the top of the Sensor Interface Assembly.)
- 2.) Thread the wires from the Sensor Interface Assembly [B-10] into the lower opening of the Junction Condulet [B-9]. Tighten the the Junction Condulet B-9] to the Sensor Interface Assembly [B-10]
(Note: If you are using tools to tighten the Sensor Interface Assembly make certain you use them ONLY on the Aluminum hex nut which came attached to the top of the Sensor Interface Assembly.)
- 3) Thread the customer-supplied remote cable [B-7] through the Watertight Strain Relief [B-8] and tighten to secure remote cable.
- 4) Wire the remote cable to the interface using 4 of the Splices provided.
Wire accordingly (R = Red, B = Black, O = Orange, Y = Yellow).
Install the condulet gasket and cover.
- 5) Route the customer-supplied remote cable [B-7] to the Transmitter Location [B-1] and secure cable.
- 6) Thread the wires from the Transmitter through the Conduit Nipple [B-2], the Conduit Seal [B-3], and the second Conduit Nipple [B-4], tighten the nipples into Conduit Seal [B-3] and turn into the Transmitter.
- 7) Stuff the supplied wadding into each end of the Conduit Seal to prevent the cement from leaking through.
- 8) Prepare the cement and pour it into the Conduit Seal. When the cement has set remove the wadding.
- 9) Thread the wires from the Transmitter through the Junction Condulet [B-5] and turn onto the Nipple [B-4].
- 10) Install the Watertight Strain Relief [B-6] and remote cable into the Junction Condulet [B-5].

- 11) Wire the remote cable to the wires from the Transmitter [A-1] using 5 of the Splices provided. Wire accordingly (R = Red, B = Black, O = Orange, Y = Yellow). Connect the shield wire to the Gray wire from the Transmitter [A-1]. Install the conduit gasket and cover.
- 10) You may mount and wire the transmitter to a power source at this time (leave transmitter unpowered).
- 11) Follow the instructions in Section 2.5 of the Transmitter User Manual to power up the transmitter.

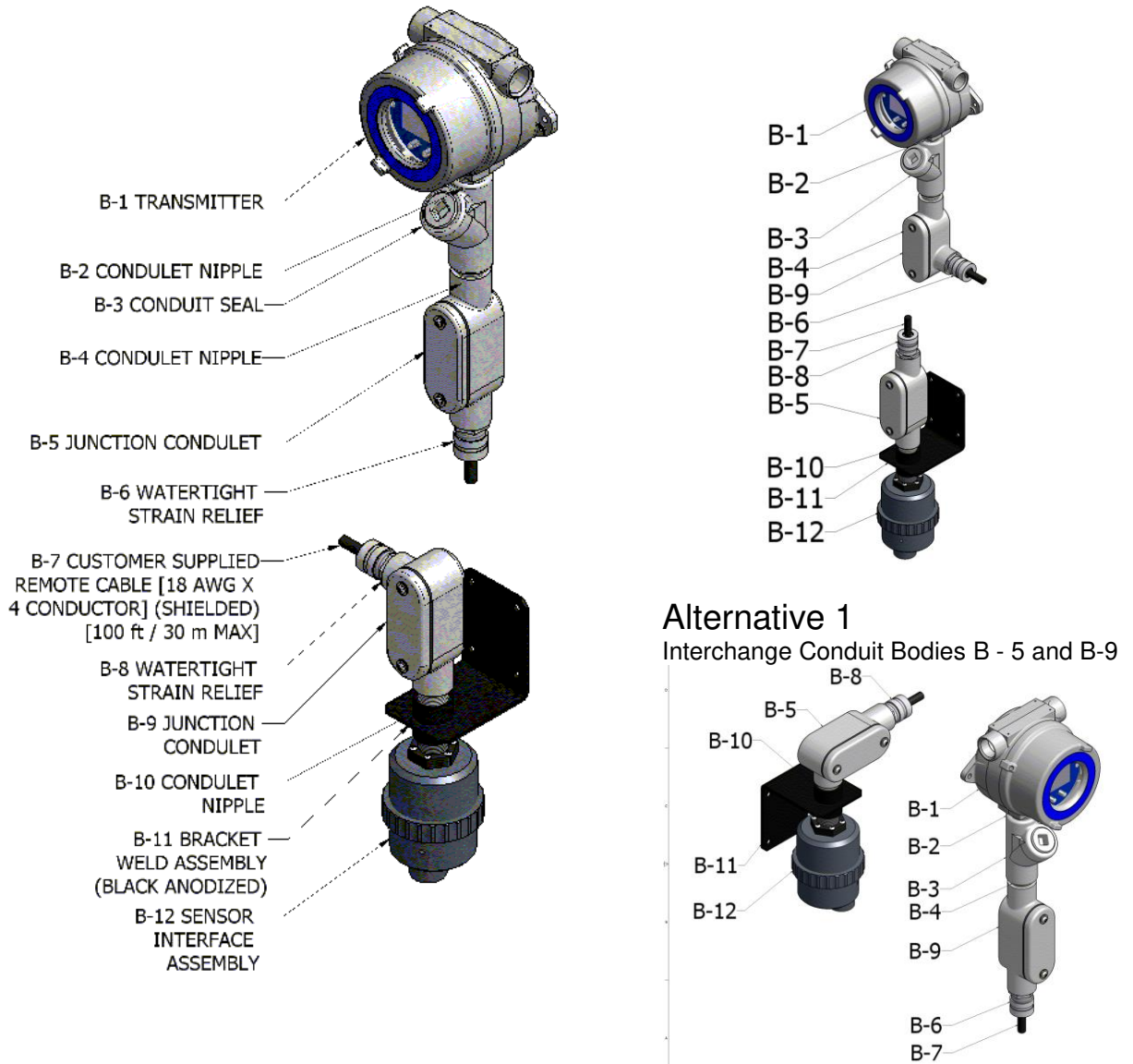

Figure 4
Remote Sensor Kit Installation
(Class I, Div. 1 or Zone 1 Explosion Proof/Flame Proof Enclosure)

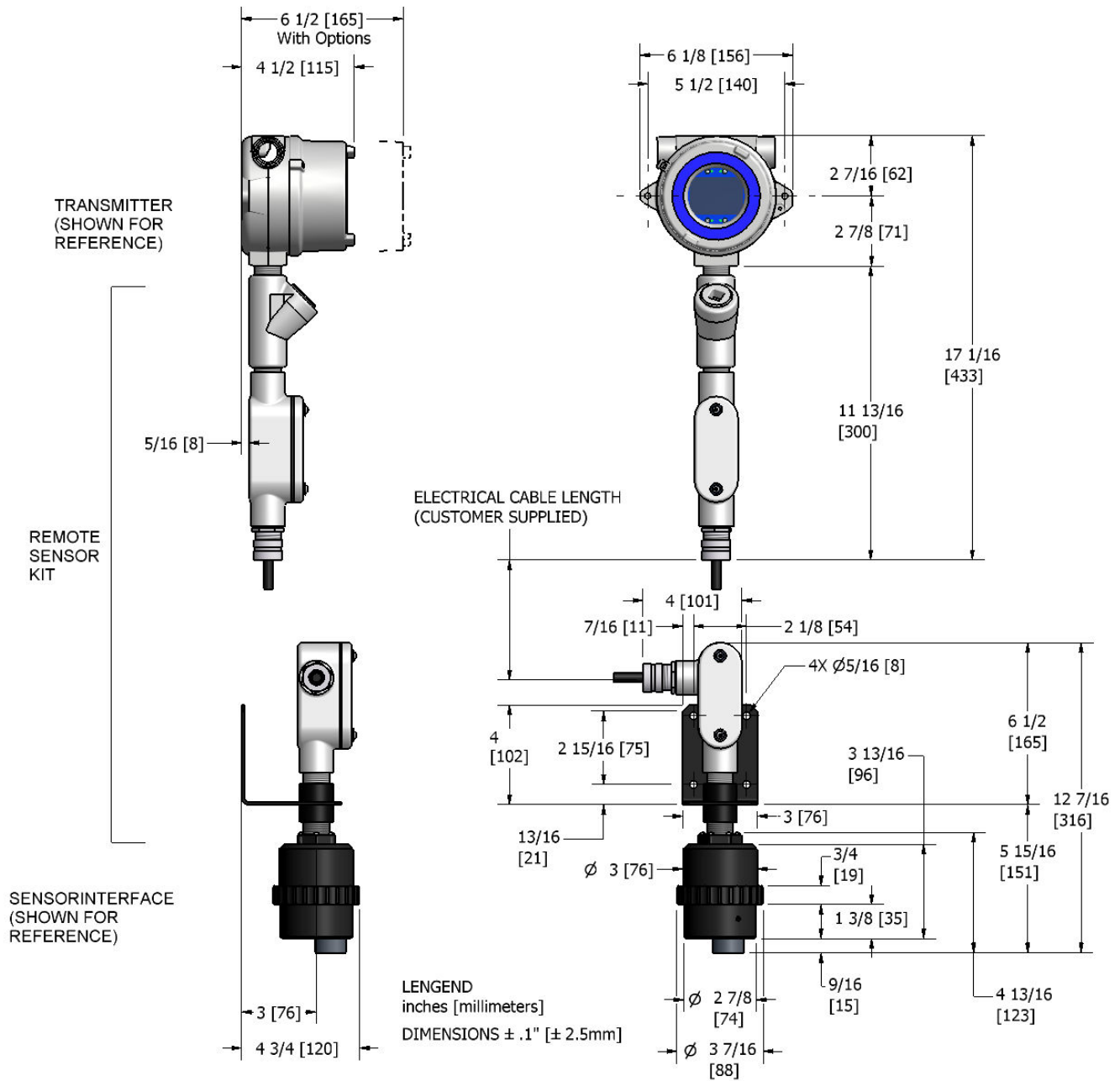

FIGURE 5
EXPLOSION PROOF (SP5XP Models) REMOTE DIMENSIONS

• 821-0207-03 Remote Option Kit

Cable Specification: 18AWG x 4 Conductor (Shielded) uH/ft < 0.2, pf/ft < 60, Max length 100ft/30m
Cable to be Customer Supplied. Belden 27326AS or equivalent.

Installation

Refer to Figure 6 and install the STD Remote Option Kit as follows:

- 1) Connect the wires from the Sensor Interface Assembly to the Transmitter, splicing in additional cable to the desired remote length. Wire accordingly (R = Red, B = Black, O = Orange, Y = Yellow). Connect the shield wire to the Gray wire from the Transmitter

Note: See Warnings at front of manual.

Note: If you are using tools to tighten the Sensor Interface Assembly into a bracket or mounting make certain you use them ONLY on the Aluminum hex nut which came attached to the top of the Sensor Interface Assembly.)

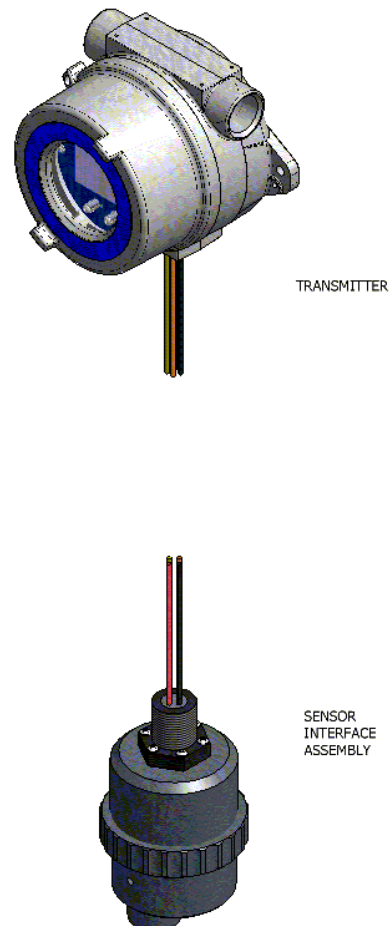

Figure 6
821-0207-03 - INTERFACE SEPARATE

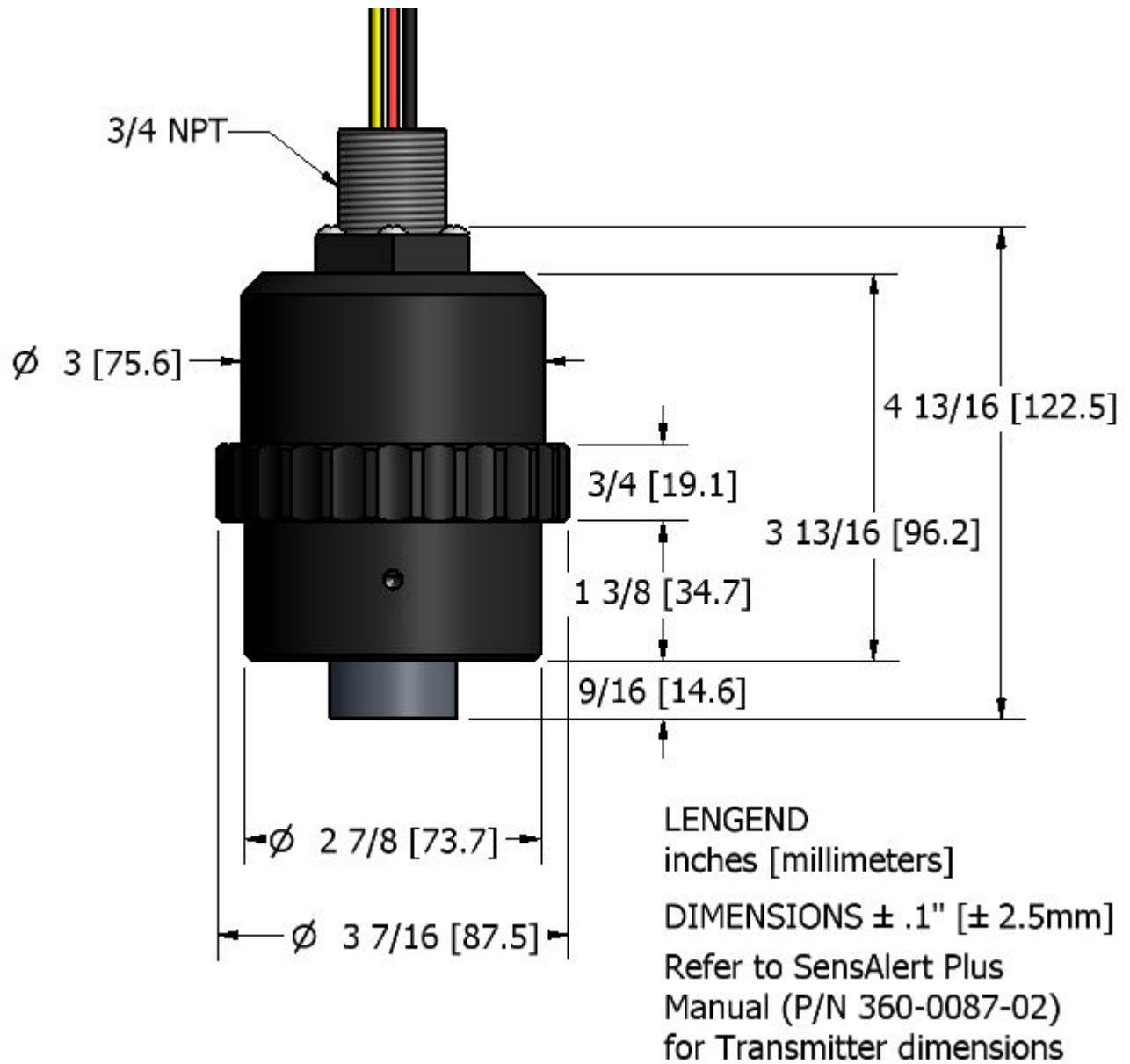

Figure 7
 821-0207-03 - INTERFACE SEPARATE REMOTE DIMENSIONS

• **821-0207-04 Remote Sensor w/ Gland Kit** **for use with SensAlert Plus SP52, SP5IS, SP5HD2,** **SP5HDIS Models**

SensAlert Plus Remote Sensor Kit (P/N 821-0207-04) contains the following items
 (Note: References in brackets refer to letter/number references in Figure 1):

Ref No.	Sensidyne.P/N	DESCRIPTION
[A-8]	550-4003-01	Aluminum Condulet Nipple, ¾ NPT (Qty 1)
[A-3]	522-0002-02	Cover, Condulet (Qty = 1) (Shown Assembled)
[A-3]	522-0002-03	Gasket, Neoprene, (Qty = 2) (Shown Assembled)
[A-3]	522-0002-04	Junction Condulet 90° with two ¾ NPT openings
[A-4, A-6].....	7017291	Watertight Cable Entry / Cable Strain Relief (Qty = 2)
(Not shown)	205-0081-01	Splice 2 pos (Qty = 4)
[A-9]	380-0021-01	Bracket Weld Assembly (Black Anodized) (Qty 1)

Cable Specification: 18AWG x 4 Conductor (Shielded) uH/ft < 0.2, pf/ft < 60, Max length 100ft/30m
 Cable to be Customer Supplied. Belden 27326AS or equivalent.

Installation

Refer to Figure 1 and install the Remote Sensor Kit as follows:

- 1) Fasten the Bracket [A-9] to the desired location. Sensor Interface Assembly must be mounted such that condensation and dust does not collect on the Sensor. Thread the wires from the Sensor Interface Assembly [A-10] through the Bracket [A-9] and Nipple [A-8], tighten to secure.
 (Note: If you are using tools to tighten the Sensor Interface Assembly make certain you use them ONLY on the Aluminum hex nut which came attached to the top of the Sensor Interface Assembly.)
- 2.) Thread the wires from the Sensor Interface Assembly [A-1] into the lower opening of the Junction Condulet [A-3]. Tighten the the Junction Condulet [A-3] to the Nipple [A-8]
 (Note: If you are using tools to tighten the Sensor Interface Assembly make certain you use them ONLY on the Aluminum hex nut which came attached to the top of the Sensor Interface Assembly.)
- 3) Thread the customer-supplied remote cable [A-5] through the Watertight Strain Relief [A-6].and tighten to secure remote cable.
- 4) Wire the remote cable to the interface using 4 of the Splices provided.
 Wire accordingly (R = Red, B = Black, O = Orange, Y = Yellow).
 Install the Condulet Gasket and Cover.)
- 5) Route and secure the customer-supplied remote cable [A-5] to the Transmitter Location [A-1].
- 6) Thread the wires through the Water Tight Strain Relief [A-4] and install into the Transmitter [A-1].
- 7) You may mount and wire the transmitter to a power source at this time (leave transmitter unpowered).
- 8) Follow the instructions in Section 2.5 of the Transmitter User Manual to power up the transmitter

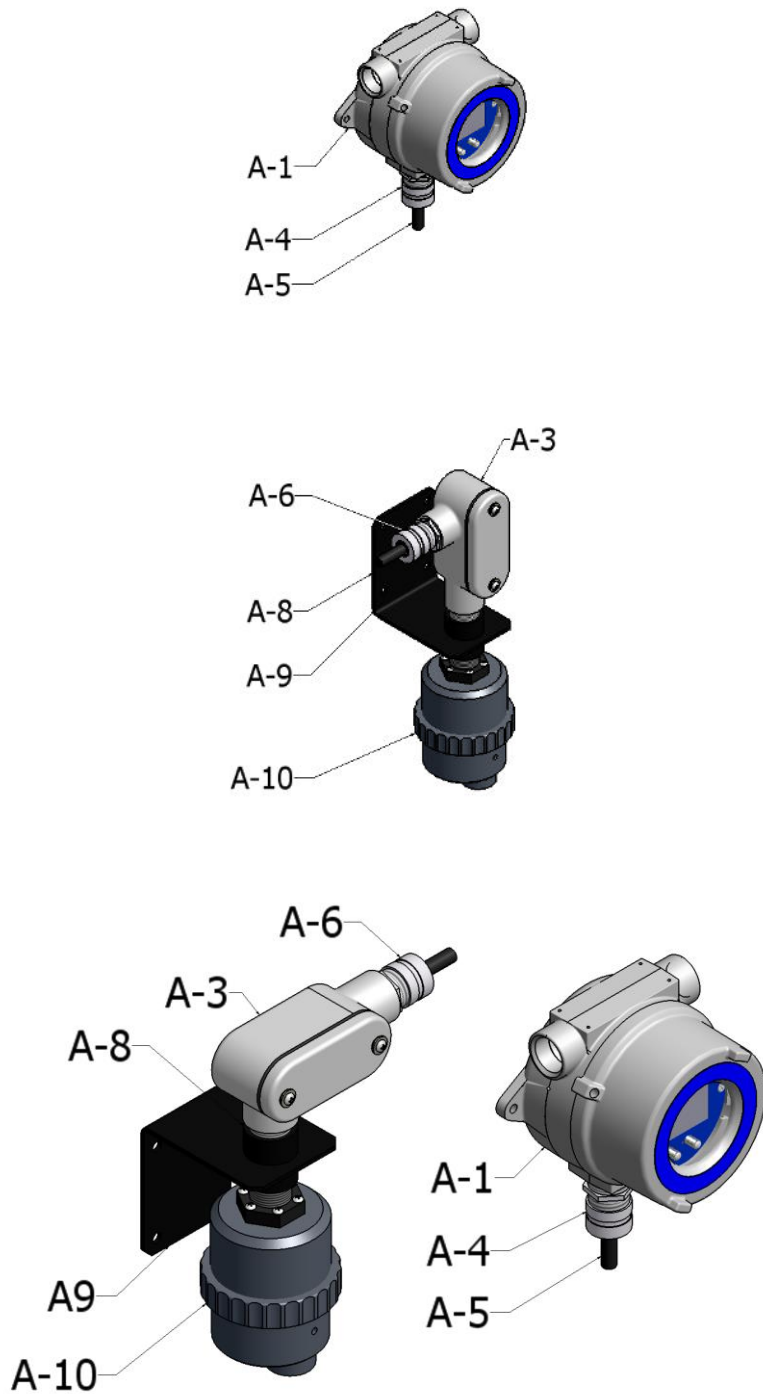

Alternative 2 Ceiling Mount
 Invert Mounting Bracket A-9

Figure 8
Remote Sensor Kit Installation
(DIV 1 Intrinsically Safe, DIV 2 and Non-Hazardous Transmitters)

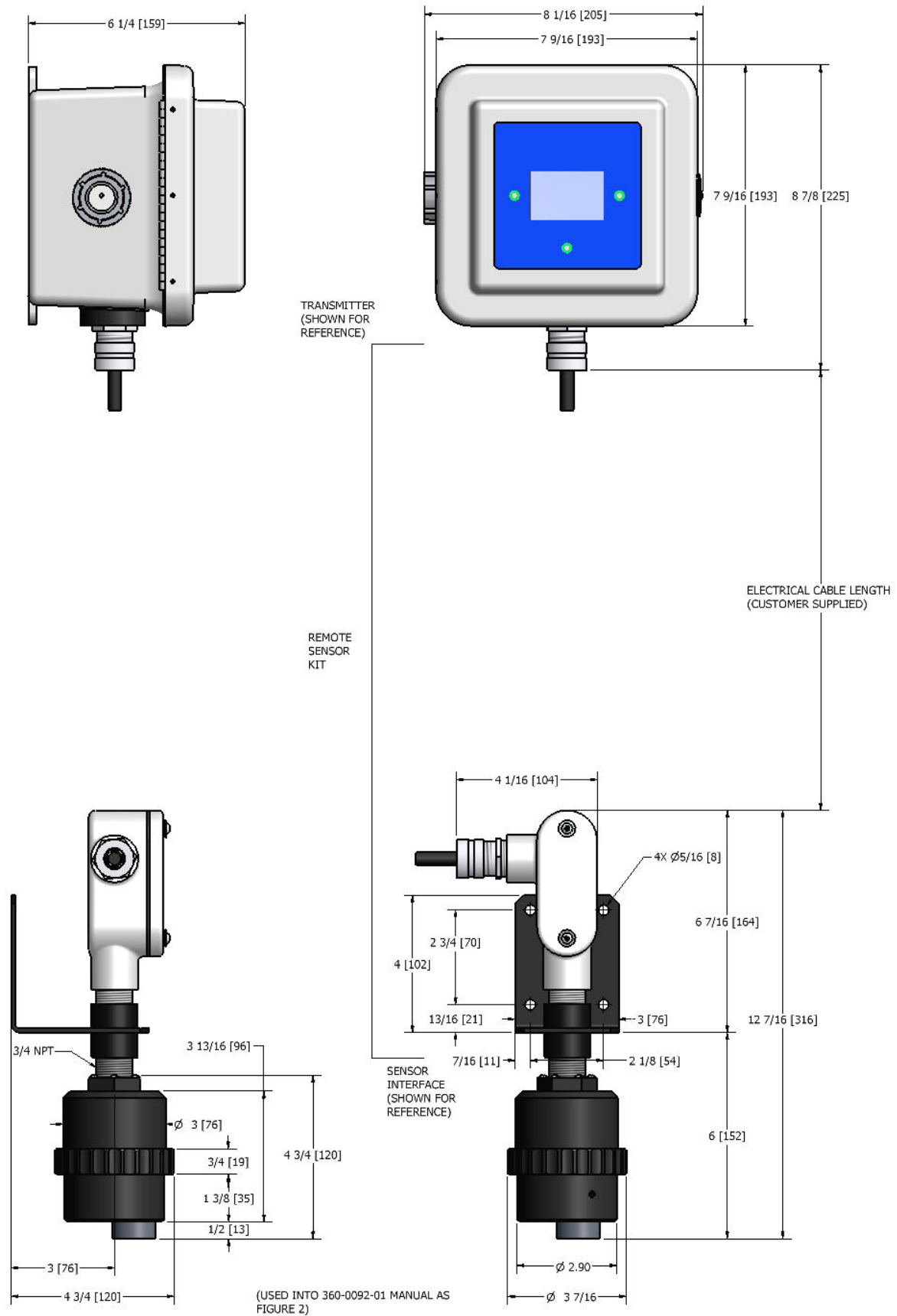

Figure 9
 FIBERGLASS TRANSMITTER ENCLOSURE (SP52 & SP5IS MODELS) REMOTE WITH WIRE GLAND DIMENSIONS

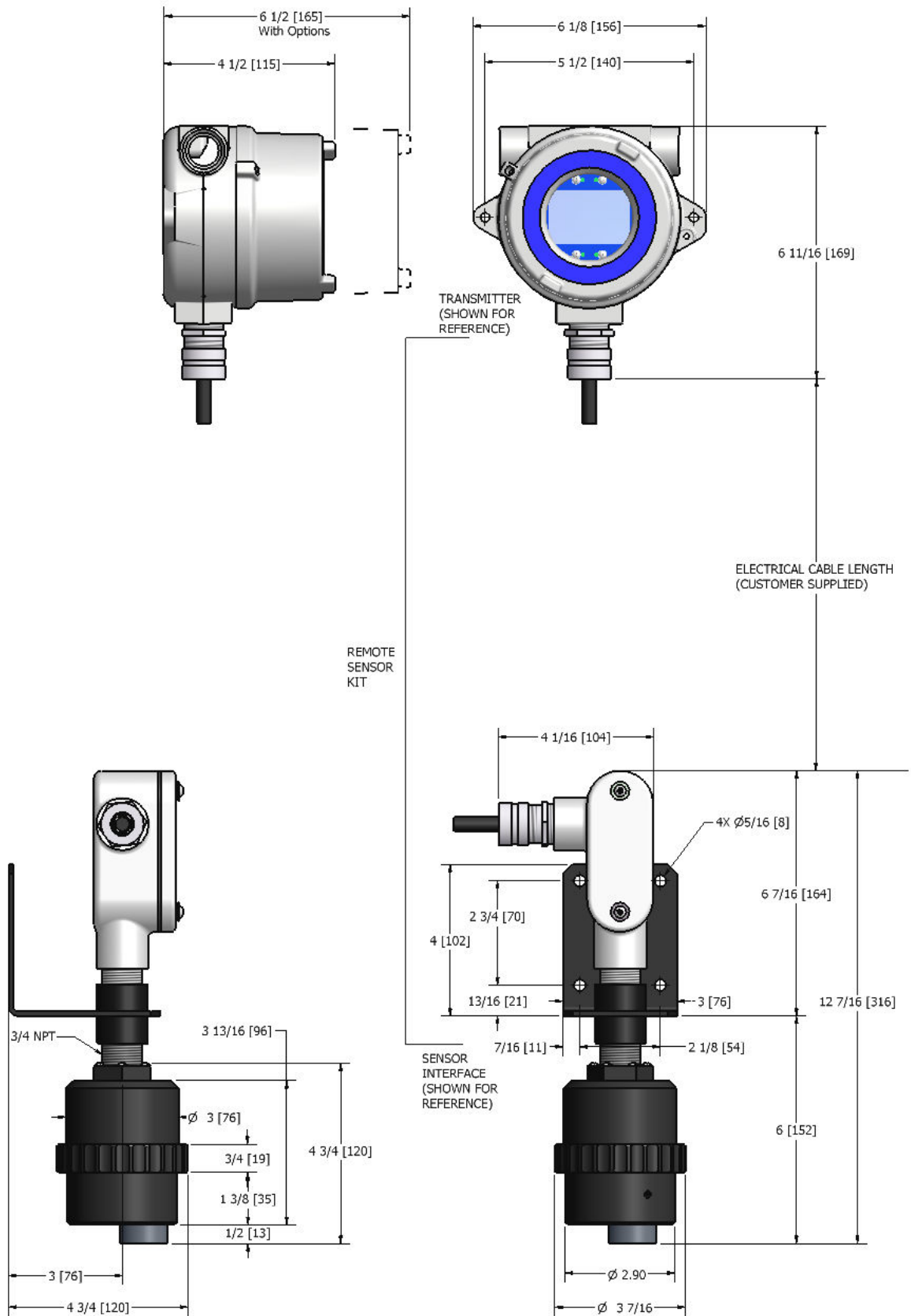

Figure 10
 ALUMINUM TRANSMITTER ENCLOSURE (SP5HD2 & SP5HDIS MODELS) REMOTE WITH WIRE GLAND
 DIMENSIONS

ADDENDUM A

TO USE CUSTOMER WIRING OTHER THAN PROVIDED WITH KIT

The terminal block for the Sensor Interface Connector is located on the Power Supply Board. For access to the Power Supply Board follow the board removal procedures listed for your particular transmitter configuration. Access the Sensor Interface Connector for Transmitter Configurations as follows:

Models (with fiberglass Enclosure)

A. SP52IS - 2 & 3 wire IS

- a. Release the Latch and open the cover of the Enclosure.
- b. The Display Assembly plugs into the Standoffs in the Enclosure. Grasp the edges of the Metal Face Plate and carefully pull the Display Assembly from the electronic stack.
- c. Locate terminal block TB2 on the Power Supply Board (labeled "I.S. OUT TO HEAD").
- d. Carefully pull the interface plug away from its socket.
- e. Using a small flat-bladed screwdriver, loosen the five terminal screws and remove the wires from the interface plug. Wire the remote cable to the wires from the Transmitter. Wire accordingly (R = Red, B = Black, O = Orange, Y = Yellow). Connect the shield wire to the Gray wire from the Transmitter.
- f. Reverse order to assemble.

B. SP52 - 2 & 3 Wire Non IS

- a. Release the Latch and open the cover of the Enclosure.
- b. The Display Assembly plugs into the Standoffs in the Enclosure. Grasp the edges of the Metal Face Plate and carefully pull the Display Assembly from the electronic stack.
- c. Remove two 4-40 screws with a Phillips Screwdriver holding the Isolation Cover and remove Isolation Cover from the Power Supply Board.
- d. Locate terminal block TB2 on the Power Supply Board (labeled "I.S. OUT TO HEAD").
- e. Carefully pull the interface plug away from its socket.
- f. Using a small flat-bladed screwdriver, loosen the five terminal screws and remove the wires from the interface plug. Wire the remote cable to the wires from the Transmitter. Wire accordingly (R = Red, B = Black, O = Orange, Y = Yellow). Connect the shield wire to the Gray wire from the Transmitter.
- g. Reverse order to assemble.

C. SP52 with Options

- a. Release the Latch and open the cover of the Enclosure.
- b. The Display Assembly plugs into the Standoffs in the Enclosure. Grasp the edges of the Metal Face Plate and carefully pull the Display Assembly from the electronic stack.
- c. Using a ¼" Nut Driver, remove and retain three (3) Standoffs which secure the Relay Board or Dummy Board.
- d. Remove the Relay Board or Dummy Board to access the Sensor Interface Connector located on the Power Supply Board.
- e. Remove two 4-40 screws with a Phillips Screwdriver holding the Isolation Cover and remove Isolation Cover from the Power Supply Board.
- f. Locate terminal block TB2 on the Power Supply Board (labeled "I.S. OUT TO HEAD").
- g. Carefully pull the interface plug away from its socket
- h. Using a small flat-bladed screwdriver, loosen the five terminal screws and remove the wires from the interface plug. Wire the remote cable to the wires from the Transmitter. Wire accordingly (R = Red, B = Black, O = Orange, Y = Yellow). Connect the shield wire to the Gray wire from the Transmitter.
- i. Reverse order to assemble.

DIVISION 1 and DIVISION 2 (with Cast Aluminum Enclosure)

D. SP5HD 2 & 3 wire IS – and - SP5XP 2 & 3 wire

- a. Loosen the set screw on the Transmitter Condulet cover (if necessary). Unscrew and remove the cover.
- b. The Display Assembly plugs into the Standoffs in the Enclosure. Grasp the edges of the Metal Face Plate and carefully pull the Display Assembly from the electronic stack. If it is necessary, carefully use a plastic screwdriver to pry up one side of the Display Assembly to get fingers under the Metal Face Plate.
- c. Locate terminal block TB2 on the Power Supply Board (labeled "I.S. OUT TO HEAD").
- d. Carefully pull the interface plug away from its socket.
- e. Using a small flat-bladed screwdriver, loosen the five terminal screws and remove the wires from the interface plug. Wire the remote cable to the wires from the Transmitter. Wire accordingly (R = Red, B = Black, O = Orange, Y = Yellow). Connect the shield wire to the Gray wire from the Transmitter.
- f. Reverse order to assemble.

E. SP5HD 3 wire Non IS – and - SP5XP 3 wire Non IS

- a. Loosen the set screw on the Transmitter Condulet cover (if necessary). Unscrew and remove the cover.
- b. The Display Assembly plugs into the Standoffs in the Enclosure. Grasp the edges of the Metal Face Plate and carefully pull the Display Assembly from the electronic stack. If it is necessary, carefully use a plastic screwdriver to pry up one side of the Display Assembly to get fingers under the Metal Face Plate.
- c. Remove two 4-40 screws with a Phillips Screwdriver holding the Isolation Cover and remove Isolation Cover from the Power Supply Board.
- d. Locate terminal block TB2 on the Power Supply Board (labeled “I.S. OUT TO HEAD”).
- e. Carefully pull the interface plug away from its socket.
- f. Using a small flat-bladed screwdriver, loosen the five terminal screws and remove the wires from the interface plug. Wire the remote cable to the wires from the Transmitter. Wire accordingly (R = Red, B = Black, O = Orange, Y = Yellow). Connect the shield wire to the Gray wire from the Transmitter.
- g. Reverse order to assemble

F. SP5HD 3 wire Non IS With Options – and - SP5XP 3 wire Non IS with Options

- a. Loosen the set screw on the Transmitter Condulet cover (if necessary). Unscrew and remove the cover.
- b. The Display Assembly plugs into the Standoffs in the Enclosure. Grasp the edges of the Metal Face Plate and carefully pull the Display Assembly from the electronic stack.
- c. Using a ¼” Nut Driver, remove and retain three (3) Standoffs which secure the Relay Board.
- d. Remove the Relay Board or Dummy Board to access the Sensor Interface Connector located on the Power Supply Board.
- e. Remove two 4-40 screws with a Phillips Screwdriver holding the Isolation Cover and remove from the Power Supply Board.
- f. Locate terminal block TB2 on the Power Supply Board (labeled “I.S. OUT TO HEAD”).
- g. Carefully pull the interface plug away from its socket.
- h. Using a small flat-bladed screwdriver, loosen the five terminal screws and remove the wires from the interface plug. Wire the remote cable to the wires from the Transmitter. Wire accordingly (R = Red, B = Black, O = Orange, Y = Yellow). Connect the shield wire to the Gray wire from the Transmitter.
- i. Reverse order to assemble

SENSIDYNE[®]

Sensidyne, LP

1000 112th Circle N, Suite 100

St. Petersburg, Florida 33716 USA

800-451-9444 • +1 727-530-3602 • +1 727-539-0550 [fax]

web: www.sensidyne.com • e-mail: info@sensidyne.com