

SENSALERT®

Four-Channel Gas Detection Controller

- Visual and Audible Annunciation
- Discrete LED and LCD Displays
- Automatic Sensor Recognition
- 4-20 mA Analog Outputs
- RS-485 Modbus RTU Output
- NEMA 4X, UL Listed Enclosure
- 115/230 VAC or 24 VDC

The SensAlert 4-Channel Controller powers and monitors up to 4 channels of gas detection. With three alarm relays per channel plus a common fault relay, the Controller provides local or remote alarm annunciation via the optional strobe and standard 90 dB buzzer. The controller has a latched alarm reset button and discrete LED value displays plus LCD displays for gas name or type and value. Discrete 4-20 mA and RS-485 Modbus RTU outputs are standard. Most SensAlert, SensAlert Plus, and SensAlert ASI transmitters, when used with this controller, will automatically configure the controller to display the gas type, range and factory default alarms, making system set up quick and easy.

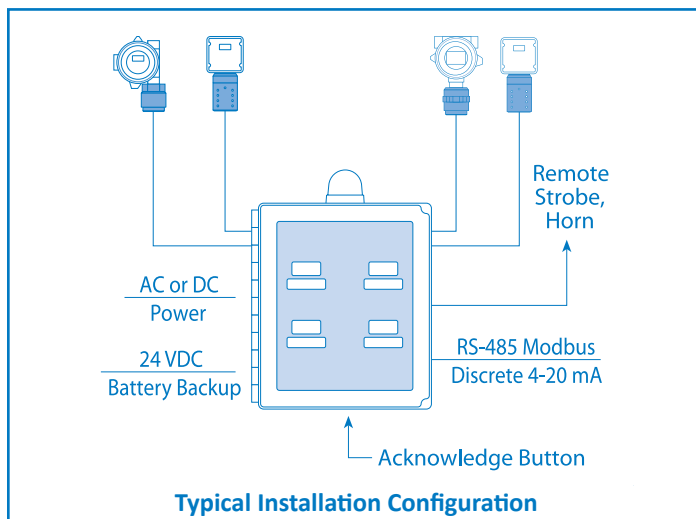

Four Channel with Strobe shown (PN# 7013227-4)

Common Industries and Applications:

- Manufacturing
 - Hazardous Material Storage
- Pharmaceutical
 - Semiconductor Fabrication
- Methane Remediation
 - Natural Gas Processing
- Hydrocarbon Pipelines
 - Float Glass Making
- Transportation Garages
 - Plating Processes
- Water & Waste Treatment
 - HVAC Industry
- Petrochemical (Plastics)
 - Utility Rooms
- Specialty Gas Bottling
 - Solvent Recovery
- Annealing Processes
 - Air Separation Plants
- Chlor-Alkali Plants
 - Coatings Manufacturing
- Fertilizer Plants
 - NGL Facilities & Pipelines
- Ferrous Metals
 - Coke Oven Batteries
- Non-Ferrous Smelting
 - Specialty Chemicals
- Poultry & Meat Processing
 - Ore Processing
- Petroleum Refining
 - Cold Storage Facilities
- Battery Rooms
 - Fruit & Vegetable Storage
- Electricity Generation
 - Textile Dyes & Chemicals

SensAlert Four-Channel Controller



Four Channel with Strobe shown (PN# 7013227-4)

SAMPLE A & E SPECIFICATION

Contractor shall supply and install a single point gas monitoring and alarming system in a NEMA 4X, UL listed enclosure for (specify gas) to be mounted outside the (specify area). The system shall have integral relays, a strobe and horn for local alarming purposes, plus a failure alarm relay contact. Local LEDs (3) shall provide alarm status. Plug-in sensors for Oxygen and all common toxic and combustible gases shall be interchangeable without any reprogramming of the system.

The unit will display the monitored gas value on a 1.5 inch minimum height, ultra-bright, 3 digit LED display, and also have a separate display for the gas name and engineering units. 4-20 mA and RS-485 (Modbus protocol) outputs will be provided.

The sensor shall be temperature compensated and intelligent to minimize drift and maintenance intervals, and will be mounted in the (floor, breathing, or ceiling) zone. The contractor will provide a one year supply of spare parts, calibration gas and kit, system start-up and training of owners' personnel.

ORDERING INFORMATION

Description	Part Number
Four Channel Controller	7013227-3
Four Channel Controller w/ Strobe	7013227-4

SensAir Compatible Four Channel Controllers

Four Channel Controller	7013227-5
Four Channel Controller w/ Strobe	7013227-6

4-Channel Specifications

Electrical

Power	85-264 VAC, 50/60 Hz or 24 VDC
Check Points	Provides reading of output current (as 40-200 mV) without breaking loop.
Termination Resistance	100 Ω fixed
Input	Four 4-20 mA (2 or 3-wire signals). Can use Sensidyne I.S. Barrier.
Outputs	Discrete non-isolated 4-20 mA (750 ohm load), and 2-wire RS485 Modbus RTU
Strobe	Red lens strobe (NEMA 4X); optional
Relays	13 on-board Form C, potential free

User Interface

LCD Display	Backlit Alphanumeric (Value, Gas, & Units)
LED Display	3 Digit x 1.5 Inch Wide Red LED (Value)
Controls	Internal push-button programming for all variables with security capability. Reset button for alarms and calibration mode

Environmental

Temperature	32° to 113°F (0° to 45°C)
Humidity	5-95 %RH, non-condensing

Enclosure

Material	Lockable wall mount NEMA 4X, fiberglass with 3/4 inch EMT connector
Dimensions	11.2" W x 12.8" H x 6.3" D 28.4 W x 32.5 H x 16.0 D cm.
Weight	10.0 lbs. (4.5 Kg)

Approval Ratings

UL listed NEMA 4X Enclosure

Note: Refer to certification documents and datasheets for specific approval and configuration information.

