

# SENSALERT IR

## Transmitter



## Instruction and Operation Manual

Document No. 360-2001-01 Rev A

# **SENSIDYNE**

Sensidyne, LP • 1000 112<sup>th</sup> Circle N, Suite 100  
St. Petersburg, Florida 33716 USA  
800-451-9444 • +1 727-530-3602 • +1 727-539-0550 [fax]  
web: [www.sensidyne.com](http://www.sensidyne.com) • e-mail: [info@sensidyne.com](mailto:info@sensidyne.com)



## Sensidyne, LP

Sensidyne, LP designs and manufactures innovative fixed system gas detection equipment, for combustible gases, oxygen, carbon dioxide and toxic gases.

### Commitment

Our quality and service are uncompromising. We back the SensAlert IR with a five-year warranty on all materials and workmanship. We offer technical support, user training and on-site service and maintenance of equipment to meet the needs of our customers.

### Gas Detection Service

Individually designed maintenance packages are available for specific customer needs. Service begins with verification of the system installation that includes an initial system check and calibration. We then offer customer training programs (on-site and at factory) to ensure that technical personnel fully understand operation and maintenance procedures. When on-the-spot assistance is required, service representatives are available to handle any questions or problems immediately.

### WARRANTY

**SENSIDYNE, LP WARRANTS SENSALERT IR PROVIDED BY SENSIDYNE TO BE FREE FROM DEFECTS IN WORKMANSHIP AND MATERIALS FOR A PERIOD OF FIVE (5) YEARS FROM DATE OF SHIPMENT FROM THE FACTORY. ANY PARTS RETURNED FREIGHT PRE-PAID TO THE FACTORY AND FOUND DEFECTIVE WITHIN THE WARRANTY WOULD BE REPAIRED OR REPLACED, AT SENSIDYNE OPTION. SENSIDYNE WILL RETURN REPAIRED OR REPLACED EQUIPMENT PRE-PAID LOWEST COST FREIGHT. THIS WARRANTY DOES NOT APPLY TO ITEMS, WHICH BY THEIR NATURE ARE SUBJECT TO DETERIORATION OR CONSUMPTION IN NORMAL SERVICE.**

**WARRANTY IS VOIDED BY ABUSE INCLUDING ROUGH HANDLING, MECHANICAL DAMAGE, ALTERATION OR REPAIR. THIS WARRANTY COVERS THE FULL EXTENT OF SENSIDYNE LIABILITY AND SENSIDYNE IS NOT RESPONSIBLE FOR REMOVAL, REPLACEMENT COSTS, LOCAL REPAIR COSTS, TRANSPORTATION COSTS OR CONTINGENT EXPENSES INCURRED WITHOUT PRIOR WRITTEN APPROVAL. SENSIDYNE OBLIGATION UNDER THIS WARRANTY SHALL BE LIMITED TO REPAIR OR REPLACEMENT OF ANY PRODUCT THAT HAS BEEN RETURNED TO SENSIDYNE FOR WARRANTY CONSIDERATION. THIS WARRANTY IS EXPRESSLY IN LIEU OF ANY AND ALL OTHER WARRANTIES EXPRESSED OR IMPLIED, AND ALL OTHER OBLIGATIONS OR LIABILITIES ON THE PART OF SENSIDYNE INCLUDING BUT NOT LIMITED TO, THE FITNESS FOR A PARTICULAR PURPOSE. IN NO EVENT SHALL SENSIDYNE BE LIABLE FOR DIRECT, INCIDENTAL, OR CONSEQUENTIAL LOSS OR DAMAGE OF ANY KIND CONNECTED WITH THE USE OF IT'S PRODUCTS OR FAILURE TO FUNCTION OR OPERATE PROPERLY.**

### CONVENTIONS

The following conventions are used in this manual.



Warning Statement – Consult this manual when this symbol is found on the product or in any related documentation.

— — — VDC (DC Voltage)

~ ~ ~ AC or DC Voltage

# 1. TABLE OF CONTENTS

## Contents

1.	TABLE OF CONTENTS .....	4
2.	SPECIFICATIONS .....	5
3.	GENERAL DESCRIPTION .....	6
4.	OPERATION .....	7
5.	OPTIONAL FEATURES .....	10
5.1.	Relay Option .....	10
5.2.	Data Card Option .....	10
5.3.	Heater Option .....	10
6.	MAGNETIC SWITCH OPERATION .....	11
6.1.	Main Menu and Sub Menus .....	14
6.2.	Calibration Menu .....	16
6.3.	Alarm Menu .....	18
6.3.1.	<b>Resetting Latch Relays/Silencing Audible Relays</b> .....	19
6.4.	Relay Menu .....	20
6.5.	Network Menu .....	23
6.6.	Hide Menu .....	24
6.7.	Self-Test Menu .....	24
6.8.	Time Date Menu .....	25
6.9.	4 – 20 MA CAL Menu .....	27
6.10.	Sensor Restore Menu .....	28
7.	DATA LOGGING (OPTIONAL) .....	29
8.	FIGURES .....	33
9.	UNIT STATUS FLASH CODES .....	39
10.	UNIT ERROR CODES .....	41

## 2. SPECIFICATIONS

**Model:**

SensAlert IR Transmitter

**For use with:**

SensAlert IR Sensor

**Output (analog):**

4-20 mA (Source type), max. 1000 Ohm load at 24 VDC supply voltage

**Output (digital):**

RS485 LAN (isolated)

**Output (relays):**

Three (3) Alarm, Low, Mid High. One (1) Fault  
Rated for 8 Amps 30 VDC or 250 VAC

**Display:**

LCD (backlit)

**Construction:**

Epoxy coated aluminum

**Operating Temperature Rating:**

CUS: -40° to +60°C at 0 to 99% RH (non-condensing)  
IECEX: -40° to +70°C

**Operating Voltage:**

24 VDC  $\overline{\overline{=}}$

Operating range: 18 to 32 VDC measured at the detector head

**Max. Current Draw: (at 24 VDC with sensor)**

Average: 250 mA

Peak: 500 mA

**Power:**

9W Max

**Weight:** 2.8kg

**Approvals:**

CSA(US) Certificate: 1513912 (LR9549)

Class I, Division 1, Groups B,C,D T5

**Installation Category:** Cat. I, Pollution Degree 2, Overvoltage II

**Altitude:** Up to 2000m

### 3. GENERAL DESCRIPTION

#### CONVENTIONS

The following conventions are used in this manual.



Warning Statement



VDC (DC Voltage)

#### SENSALERT IR

The SensAlert IR Transmitter is designed to be used with the SensAlert IR Sensor. The SensAlert IR is a microprocessor based intelligent transmitter continuously monitoring information from the gas sensor. The LCD of the SensAlert IR displays the gas concentration and sensor status. The SensAlert IR has one (1) "Alarm" LED and one (1) "Status" LED. The SensAlert IR also has three (3) magnetic switches located around the circumference of the unit. This manual will describe the operation and use of the SensAlert IR transmitter.

#### Features

- *Explosion Proof*
- *Back lighted LCD Display*
- *Low Cost*
- *Plug and play toxic, oxygen and combustible gas sensors*
- *Self-check system*
- *4-20 mA output*
- *RS-485 Interface (Isolated)*
- *Optional alarm and fault relays*
- *Optional LCD heater for cold applications*
- *Optional Data card for datalogging*
- *Non-intrusive programming*
- *Non-intrusive calibration*
- *Removable, non-volatile, time stamped data logging*
- *Digital communication link to SensAlert IR Sensor*
- *Multi-port housing for easy installation*

## 4. OPERATION

### Installation and Startup



**Warning:** The user shall be made aware that if the equipment is used in a manner not specified by the manufacturer, the protection provided by the equipment may be impaired.

The first step in the installation process is to establish a mounting location for the SensAlert IR Transmitter and Sensor. Select a sensor location that is typical of the atmosphere to be monitored or close to the anticipated source of a dangerous gas. The SensAlert IR Transmitter does not have to physically connected (attached) to the SensAlert IR Sensor.

It is very important that the SensAlert IR Transmitter and Sensor be properly located enabling it to provide maximum protection. The most effective number and placement of sensors vary depending on the conditions of the application. When determining where to locate gas sensors the following factors should be considered.

When installing, make sure power is off when connecting the sensor, field, and relay wiring to the appropriate terminal blocks. DO NOT turn the power back on until the transmitter is secured to the housing using all four hex head screws.

- What are the characteristics of the gas that is to be detected? Is it lighter or heavier than air? If it is lighter than air the sensor should be placed above the potential gas leak. Place the sensor close to the floor for gases that are heavier than air. Note that air currents can cause a gas that is heavier than air to rise. In addition, if the temperature of the gas is hotter than ambient air or mixed with gases that are lighter than air, it could also rise.
- How rapidly will the gas diffuse into the ambient air? Select a location for the sensor that is close to the anticipated source of a gas leak.
- Wind or ventilation characteristics of the immediate area must also be considered. Movement of air may cause gas to accumulate more heavily in one area than in another. The sensor should be placed in the areas where the most concentrated accumulation of gas is anticipated. For outdoor applications with strong wind conditions, it may require the sensors to be mounted closer together and on the downwind side, to the anticipated area of a gas leak. Also take into consideration for indoor applications, the fact that many ventilation systems do not operate continuously.
- The sensor should be accessible for maintenance.
- Excessive heat or vibration can cause premature failure of any electronic device and should be avoided if possible.
- Follow all national and local installation codes and practices.

The SensAlert IR Transmitter has three (3)  $\frac{3}{4}$ " NPT threaded connectors for mounting and wiring the sensor and transmitter into a permanent installation.

Field wiring connections are made on the backside of the SensAlert IR Transmitter printed circuit assembly (PCA). For wiring details refer to Figure 2 in the back of the manual.  $\frac{3}{4}$  NPT threads must pass L1 thread/plug gauge.

#### **Mounting:**

Mount the SensAlert IR Transmitter to rigid wall (wood based or stronger) or bulkhead structures using 1" or longer fasteners with a minimum  $\frac{3}{16}$ " diameter. Mounting to drywall (wallboard, plasterboard, etc.) or similar material is not recommended.

**Wiring:**

Wire insulation for relay contacts should have a minimum breakdown voltage of twice that of the working voltage of the signal. E.g. 110v lines should have a minimum insulation breakdown voltage of 220v, 240v signals should have a minimum insulation breakdown voltage of 480v.

Wire insulation should be temperature rated for greater than or equal to 70°C.



There are 2 earth screws on the SensAlert IR Transmitter. One is on the outside of the enclosure and the other is located on the inside of the enclosure. Both are marked with earth ground symbols and green screws. Installation of this wire should include the use of a locking feature (i.e. locking washer).

**Power wire sizing:**

0 to 500 feet, recommended wire gauge size 16 AWG

501 to 1000 feet, recommended wire gauge size 14 AWG

Shielded cable is recommended. Wiring should be installed in metal conduit with no other cabling in the same conduit. Use copper conductors only on all terminal blocks.

Colder applications may require an optional LCD heater for the SensAlert IR Transmitter to make sure the LCD can be always visible. This is a closed loop heater that will turn on when the temperature drops below approximately 2°C and will turn off when the temperature rises above approximately 3°C. This feature has been approved for hazardous locations.

**Conduit:**



For hazardous location installations seals must be installed within 18 inches of conduit entries.

The SensAlert IR Transmitter has three (3) ¼" NPT threaded ports for mounting and wiring the sensor(s) and transmitter into a permanent installation.

Field wiring connections are made on the backside of the SensAlert IR Transmitter printed circuit assembly (PCA). For connection details refer to Figure 2.

Shielded cable is recommended. Wiring should be installed in metal conduit with no other cabling in the same conduit.

**Power Supply:**

The SensAlert IR Transmitter must be powered using a power supply rated for CAN/CSA C22.2 No. 61010-1-12 and ANSI/UL 61010-1 **OR** a class 2 power supply as defined in Canadian Electrical Code C22.1 Section 16-200 and/or National Electrical Code article 725.121.

**Real Time Clock Battery:**

The SensAlert IR Transmitter uses a real time clock that runs on a 3V, 1220 battery.

**Warnings:**



KEEP COVER TIGHT WHILE CIRCUITS ARE ALIVE



GARDER LE COUVERCLE BIEN FERME TANT QUE LES CIRCUITS SONT SOUS TENSION

**Warm-up**

When power is applied to the SensAlert IR Transmitter, it enters a one (1) minute warm-up mode. The output current will be 0.8 mA during the warmup period. At the end of the warm-up period with no faults present, the SensAlert IR Transmitter automatically enters the normal operating mode (4.0 mA with no gas present). If a fault is present after warm-up, the detector current output and LCD will indicate a fault. The Fault LED will also indicate the fault.

**Note: If the SensAlert IR Transmitter cannot communicate with the sensor, it will indicate sensor fault. Check the wiring and the +24VDC of the sensor if this occurs.**

**Normal**

In the normal operating mode, the 4 to 20 mA signal levels correspond to the detected gas concentration. The transmitter continuously checks for and displays system faults or initiation of calibration and automatically changes to the appropriate mode.

The 4 to 20 mA output of the SensAlert IR Transmitter sensor is a non-isolated current source.

**Current Output**

<b>Current Output</b>	<b>Status</b>
0-20 mA	Normal measuring mode
0.0 mA	Unit Fault
0.2 mA	Reference channel fault
0.4 mA	Analytical channel fault
0.8 mA	Unit warm up
1.0 mA	Optics fault
1.2 mA	Zero drift fault
1.6 mA	Calibration fault
2.0 mA	Unit spanning
2.2 mA	Unit zeroing
4.0 mA	Zero gas level (0% of full scale)
5.6 mA	(10% of full scale)
8.0 mA	(25% of full scale)
12 mA	(50% of full scale)
16 mA	(75% of full scale)
20 mA	Full scale (100% of full scale)
20.1- 23 mA	Over-range (> 100% of full scale)

Once the fault is cleared the SensAlert IR Transmitter will automatically resume normal operation. See section 0 for status code information

If a fault is detected, the SensAlert IR Transmitter will display a fault notification on the LCD display giving the error code in decimal. Refer to section 10 for more information on the error codes.

## 5. OPTIONAL FEATURES

The SensAlert IR Transmitter offers 3 options. A relay option for signaling alarm/faults, a data card option for logging gas occurrences, alarms/faults, and an LCD heater option for applications where the temperature goes below 2°C.

### 5.1. Relay Option

The SensAlert IR Transmitter offers an option for 3 alarm relays (low, mid, and high) and one fault relay. These relays are rated for 8 Amps 30 VDC/250 VAC.

When the transmitter sees that the gas concentration of the sensor has exceeded the low, mid, or high threshold, the low, mid, and/or high relay will be toggled on.

If the transmitter sees that the sensor is in a fault or has become disconnected, the fault relay will toggle. For more information on the different ways the relays can be configured, see Section 6.4, "Relay Menu".

### 5.2. Data Card Option

The Data Card Option of the SensAlert IR Transmitter uses a MMC card to log different events to help track and changes or sensor behavior. See below for events that get logged:

1. **Gas Change Events-** When a gas level rises or falls according to a pre-determined delta (change) threshold, a gas record is entered into the log by the SensAlert IR Transmitter, containing the timestamp and gas level at the time of the event.
2. **Alarm Events-** When a gas level rises and triggers one of the alarms (low, medium, high) or when a sensor fault is detected, an alarm event is recorded along with a timestamp, the alarm type, and the gas level at the time of the event.
3. **Calibration Events-** When the user performs a calibration operation, a timestamp and calibration indicator is recorded.
4. **Parameter Change Events-** When the user changes settings on the SensAlert IR Transmitter, a change event recorded is recorded along with a time stamp and the SensAlert IR Transmitter parameters.
5. **Sensor Warm-up Events-** When either the SensAlert IR Transmitter or a sensor head is replaced and enters the warm-up operation, a sensor warm-up event is entered along with a timestamp and all the new sensor and SensAlert IR Transmitter parameters.
6. **Memory Card Events-** Whenever the Memory Card is removed or inserted, this event is recorded in the log along with all sensor, SensAlert IR Transmitter, and card unit serial number parameters to indicate a possible change in SensAlert IR Transmitter unit data, to help prevent confusion from different SensAlert IR Transmitter units using the same Memory Card at different times.

See Section 7, "Data Logging" for more information on how to read the file format.

### 5.3. Heater Option

A heater option is available for SensAlert IR Transmitter that are going into cold climates. This is a closed loop heater that heats the LCD screen. It will turn on when the temperature drops below approximately 2°C and will turn off when the temperature rises above approximately 3°C.

This option ensures that the LCD will be readable, even at cold temperatures.

To conform to the performance standard 60079-29-1, the SensAlert IR Transmitter must have all 3 features and be used with the SensAlert IR Sensor 0-100%LEL Methane gas detector.

For more information regarding any features, contact Sensidyne.

## 6. MAGNETIC SWITCH OPERATION

The SensAlert IR Transmitter has three (3) magnetic switch pickups on the Display PCA. The picture below shows the location of the magnetic switches labeled UP, DOWN and ENTER. Placing a magnet near one of the switches will cause the following operations to occur.

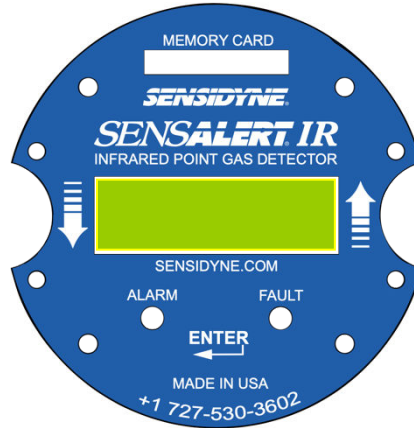

Switch	Operation
ENTER	Enter Menu Mode, Selects a menu to Enter
UP	Moves up through Menu selections
DOWN	Moves down through Menu selections

For further details on gas sensor calibration refer to the appropriate Sensidyne SensAlert IR Sensor instruction manual.

The LCD contrast potentiometer, (POT1) is located under the protective faceplate shown above on the front side (LCD side) of PCB to the left of the LCD.

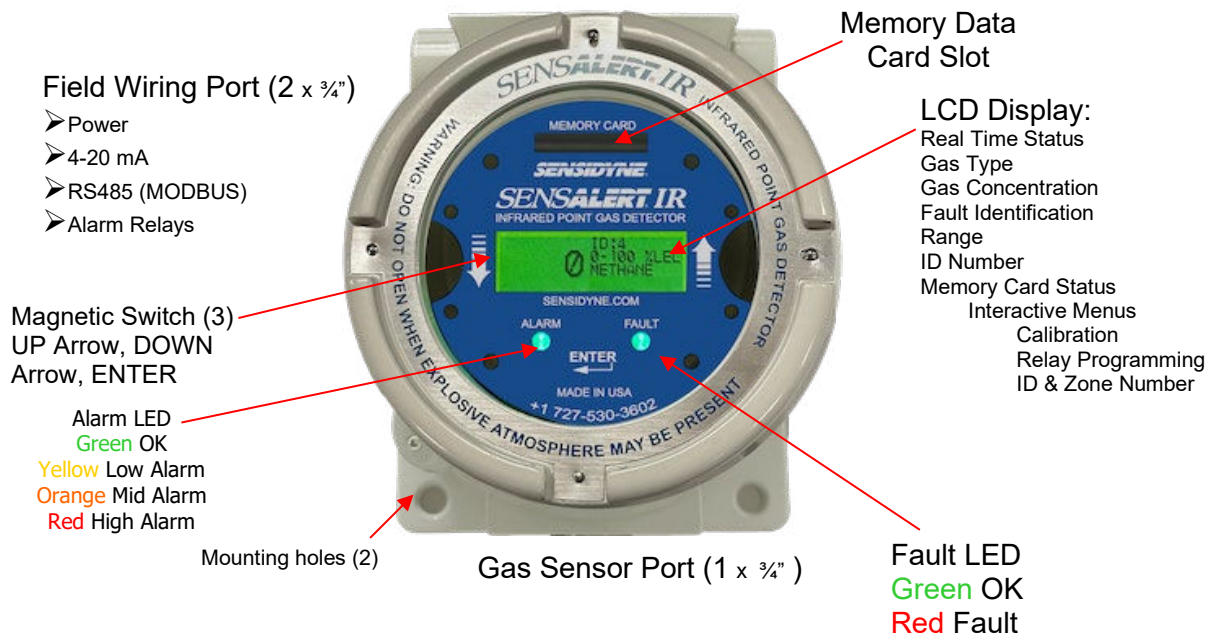

# SensAlert IR Transmitter

## MENU OPERATION

### Initial Power Up Sequence of the SensAlert IR Transmitter

SYSTEM BOOT PROCESS  
--- WAIT FOR SYNC ---

SYSTEM BOOT PROCESS  
-WAIT FOR SENSOR -

INITIALIZING

WARM	ID: xx
UP	SN: xxxxx
	TYP: x.x
	VER: x.x

WARM	ID: xx
UP	0-20.0PPM
	WF6
	ENT TO ABORT

0	ID: 1
	0-20.0 PPM
	WF6
	MC - REMOVED

In normal operating mode. Actual gas concentration will be displayed to the left of ID #, Range, Gas Type, MC (Memory Card) status.

During Warm Up, FAULT LED will be solid Blue and ALARM LED will be falshing Yellow – Blue.

MC – REMOVED indicates the MEMORY CARD (MC) in not installed in the SensAlert IR Transmitter. Other MC indications are OK, FAULT, FULL.

Selecting Enter when the SensAlert IR Transmitter is in normal operating mode will advance to the following display:

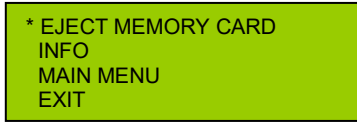

Selecting Enter will allow the operator to safely remove the Memory Card.

Arrow Down

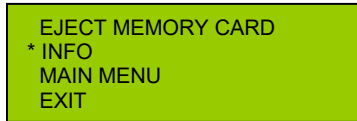

Selecting Enter at UNIT INFO displays the following:

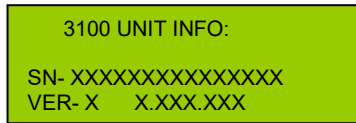

SN is the SensAlert IR Transmitter serial number. VER is the SensAlert IR Transmitter software version number. Selecting Enter again will return the display to the main info menu.

Sensor Status Menu

TYP: Sensor type (32.0 is SensAlert IR Sensor)

SN: Sensor serial number.

VER: Version of sensor software.

CAL: Calibration date of sensor.

Selecting MAIN MENU is covered in the next pages of the manual.

Select Exit to go back to

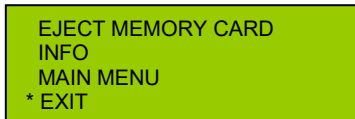

### 6.1. Main Menu and Sub Menus

EJECT MEMORY CARD  
INFO  
\* MAIN MENU  
↓

Enter

\* CALIBRATION  
ALARM  
RELAY  
↓

**Calibration Menu**  
Used to calibrate the gas sensor.

Down Arrow

CALIBRATION  
\* ALARM  
RELAY  
↓

**Alarm Menu**  
Used to set alarm level set points and parameters.

Down Arrow

CALIBRATION  
ALARM  
\* RELAY  
↓

**Relay Menu**  
For setting alarm relay On & Off delay & Energized states.

Down Arrow

↑  
\* NETWORK HIDE NO  
↓

**Network Menu**  
Used to set Zone #, ID # and Select Online

Down Arrow

↑  
NETWORK \* HIDE NO  
↓

**Hide Menu**  
Hide is used to blank the display up to low alarm setting

Down Arrow

↑  
\* SELF TEST DATE TIME  
↓

**Self Test Menu**  
Generates a signal on the display, RS485 & 4-20 mA

Down Menu

↑  
SELF TEST \* DATE TIME  
↓

**Date Time Menu**  
Sets the date and time in the real time clock.

Down Arrow

\* 4 – 20 MA CAL  
SENSOR RESTORE  
EXIT

**4 – 20 MA CAL**  
Allows user to increase or decrease 4.0 mA current output, or adjust 20 mA current output

Down Arrow

4 – 20 MA CAL  
\* SENSOR RESTORE  
EXIT

**Sensor Restore**  
Allows user to Restore the sensor to its original factory settings

Down Arrow

↑  
4 – 20 MA CAL  
SENSOR RESTORE  
\* EXIT

**Exit** back to normal operation.

## 6.2. Calibration Menu

If the user is going to perform a span calibration, a zero calibration is **REQUIRED** to be performed first.



Using the Up and Down arrows allows the operator to move the cursor (\*) to select a function.

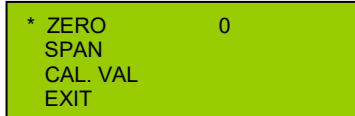

To Zero the sensor apply clean air (N2 for an oxygen sensor) and select enter. The following will be displayed.

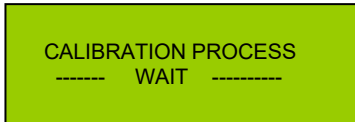

Then the following will be displayed.

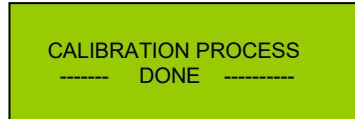

Once complete the following will be displayed. The sensor has been successfully zeroed.

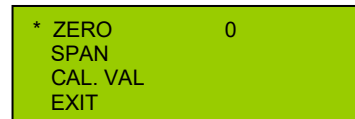

Arrow down to CAL. VAL to verify the span gas calibration value matches the value of the span gas calibration on hand. If not, select Enter and the following screen will appear.

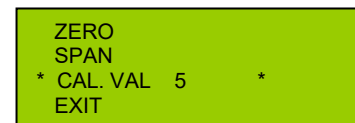

Using the Up and Down arrows will allow the operator to change the calibration gas value of the sensor to match the calibration gas used to span the sensor. Once the correct value is displayed select Enter and the sensor will be uploaded with the new calibration gas value.

To Span the sensor with calibration gas use the Up and Down arrows to select the following display.

```
ZERO          3
* SPAN
CAL. VAL
EXIT
```

Apply span gas to the sensor for the appropriate amount of time in order for the sensor to stabilize. The gas reading is displayed to the right of ZERO. Once stable select Enter. This will go the display:

```
CALIBRATION PROCESS
----- DONE -----
```

If calibration span gas is still present the display will read:

```
GAS LEVEL : 5
CALIB. GAS PRESENT
---- WAIT ----
```

Apply clean air to the sensor to reduce this reading. Alternatively, press enter. The display will advance to the following:

```
* ZERO          0
SPAN
CAL. VAL
EXIT
```

This completes the calibration and the device can be put back into the normal operating mode. Arrow Down to

```
ZERO
SPAN
CAL. VAL
* EXIT
```

Enter

```
↑
* EXIT
```

Enter again and the SensAlert IR Transmitter returns to normal operation.

### 6.3. Alarm Menu

The alarm menu allows the user to configure the alarm thresholds, latch behavior, and the active high/low setting.

The default alarm threshold for the SensAlert IR Transmitter are as follows:

Alarm	Threshold
Low	20% of Full Scale
Mid	40% of Full Scale
High	60% of Full Scale

These can be configured as the user requires.

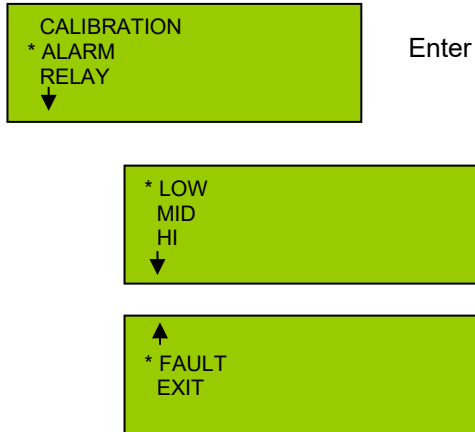

Select the Alarm Relay (LOW, MID, HI, FAULT) using the down arrow. Once the cursor is on the alarm relay you wish to configure, hold the magnet over Enter. The example LOW will be used. The same operations can be used to set the MID, HI or FAULT relays.

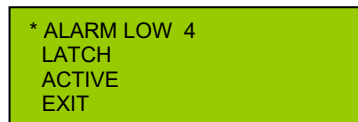

Selecting Enter will display the following screen allowing the alarm set point to be programmed. Using the Up and Down arrows will change the set point. Once the correct set point is displayed select Enter and the new value will be accepted.

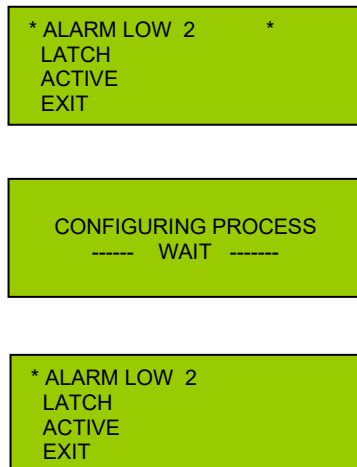

Arrow Down

```

ALARM LOW
* LATCH      NORMAL
ACTIVE
EXIT

```

Selecting Enter will allow the operator to change the operation of the relay operation from Non-Latching (NORMAL) to Latching (LATCHING) or to Audible (AUDIBLE).

Each relay; Low, Mid, High and Fault; can be individually configured to latch when it is activated. Setting a relay to 'latch' will cause it to remain activated after the condition that activated the relay has cleared. This causes the user to acknowledge the activation to clear any alarms. See the end of this section on how to do this. Setting the 'latch' type to audible means that the relay can be silence, or turned off, before the criteria for the relay to turn off is met (i.e. if the gas concentration drops below the threshold). See Section 6.3.1 on how to do this.

### 6.3.1. Resetting Latch Relays/Silencing Audible Relays

If the relays are set to Latching or Audible, the magnet can be used to reset (unlatch or silence) the relays by selecting any magnetic pickup switch UP arrow, DOWN arrow or ENTER.

**NOTE:** As required by 60079-29-1 performance standard, the default LATCH setting for the HIGH alarm is LATCHING.

Arrow Down

```

ALARM LOW
LATCH
* ACTIVE      HI
EXIT

```

Selecting Enter will allow the operator to change the operation of the relay operation from Active HI to Active LOW. HI activates the relay on a rising alarm level. LOW activates the relay when the alarm threshold falls below the alarm set point. Once the correct operation is selected, use the Down arrow to advance to the next menu item.

Arrow Down

```

ALARM LOW
LATCH
ACTIVE
* EXIT

```

Selecting Exit will advance to the next menu.

```

* LOW
MID
HI
↓

```

This menu will allow the operator to select another relay to program. Or select Fault or Exit and the next display will be:

```

↑
FAULT
* EXIT

```

Selecting Enter on this display will put the SensAlert IR Transmitter back into normal operation.

### 6.4. Relay Menu

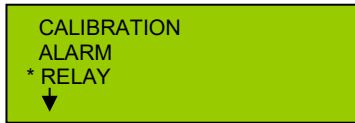

Selecting Enter will advance to the following menu.



Arrow down to the next screen will be



Select the Alarm Relay (LOW, MID, HI, FAULT) that is to be configured using the down arrow. Once the cursor is on the correct alarm relay, hold the magnet over Enter. The example LOW will be used. The same operations can be used to set the MID, HI, or FAULT relays.



Select Enter

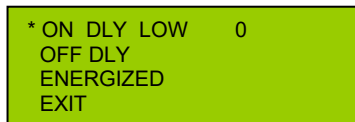

Select Enter

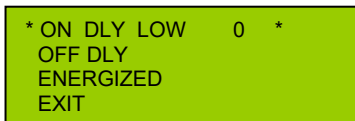

Using the Up and Down arrows the operator can change the ON delay time for the relay to actuate after the alarm threshold has been exceeded. The time is measured in seconds (0-255). Once the correct time is displayed select Enter to accept the new value. Then Exit the menu and proceed on to the next selection.

In this example the Low alarm relay will actuate 30 seconds after the Low set point is exceeded.

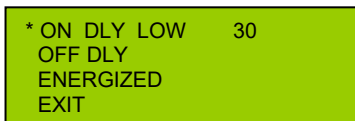

Select Enter

```

ON DLY LOW
* OFF DLY      0
ENERGIZED
EXIT
    
```

Select Enter

```

ON DLY LOW
* OFF DLY      0 *
ENERGIZED
EXIT
    
```

Using the Up and Down arrows the operator can change the OFF delay time for the relay to turn OFF after the reading has decreased below the alarm point threshold. The time is measured in seconds (0-255). Once the correct time is displayed select Enter to accept the new value. Then Exit the menu and proceed on to the next selection.

In this example the Low alarm relay will stay energized for 60 seconds after the alarm has cleared.

```

ON DLY LOW
* OFF DLY      60
ENERGIZED
EXIT
    
```

Arrow Down

```

ON DLY LOW
OFF DLY
* ENERGIZED NO
EXIT
    
```

Selecting Enter will allow the operator to change the operation of the relay coil from normally de-energized (ENERGIZED NO) to normally energized (ENERGIZED YES). Once the correct operation is selected, use the Down arrow to advance to the EXIT menu. Select Enter to go back to the Relay Menu

```

* LOW
MID
HI
↓
    
```

This menu will allow the operator to select another relay to program. Or select Exit and the next display will be:

```

↑
* FAULT
EXIT
    
```

Arrow Down to Exit

```

↑
FAULT
* EXIT
    
```

Enter

```

↑
* EXIT
    
```

Selecting Enter will return the SensAlert IR Transmitter to normal operation.

**NOTE:** The fault relay is set to energized by default. This is so if the device loses power, the relay toggles and indicates to the unit's power has been lost. For this to work, the fault relay must be utilized by being wired to a light, horn, or some other indicator.

## 6.5. Network Menu

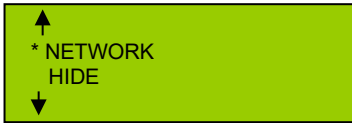

Select Enter

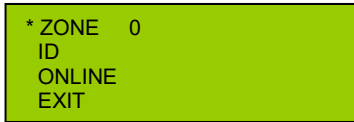

Select Enter to change the Zone number of the SensAlert IR Transmitter.

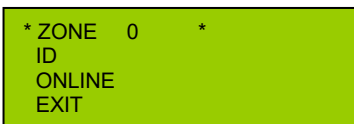

Use the Up and Down Arrows to change the Zone number (0-16). Once the correct Zone number is displayed select Enter. If the zone is set to 0, this will be treated as zone 1.

Arrow Down to ID. To change the ID number select Enter. Use the Up and Down Arrows to change the ID number (0-255). Once the correct ID number is displayed select Enter.

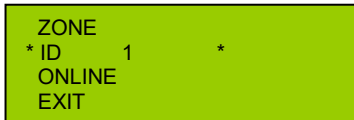

Arrow Down to Online.

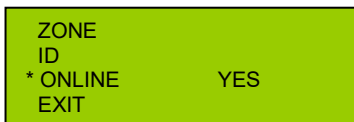

Using Enter the operator can toggle between Online YES and Online NO. Online YES turns on the MODBUS RS485 communication. Online NO turns the MODBUS RS485 communication off.

Arrow Down to Exit



Enter



### 6.6. *Hide Menu*

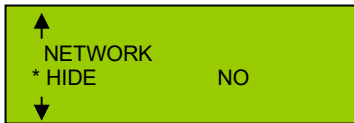

Using Enter the operator can toggle between Hide YES and Hide NO. The Hide function allows the operator to not display the gas reading until the Low Alarm threshold is exceeded. All outputs will function as normal when the Hide mode is selected to YES.

### 6.7. *Self-Test Menu*

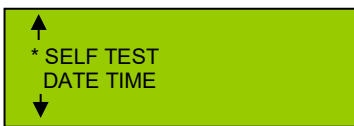

Selecting Enter for the Self Test will make the sensor generate a 4-20 mA input into the SensAlert IR Transmitter from 4 mA to 20 mA (0-fullscale). In the self test mode, the SensAlert IR Transmitter outputs are fully functional. The SensAlert IR Transmitter will display the rising gas level, the 4-20 mA output will increase to 20 mA, the relays will actuate and the RS485 information will be transmitted to the control system. The following screen will be displayed:

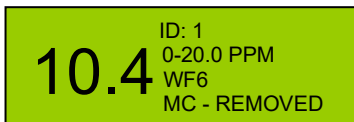

Once the unit reaches full scale the SensAlert IR Transmitter automatically returns to normal.

## 6.8. Time Date Menu



Entering this menu will allow the operator to set the time and date of the SensAlert IR Transmitter real time clock.

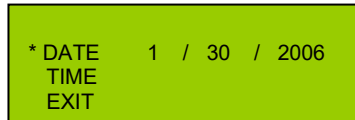

Selecting Enter will locate a cursor (\*) above the number allowing the operator to use the Up Down arrows to increase or decrease the numbers. Once the correct number is displayed, select Enter with the magnet and the cursor will advance to the next number.

Date is MM/DD/YYYY. Time is HH/MM/SS. Below is an example.

Enter from above display.

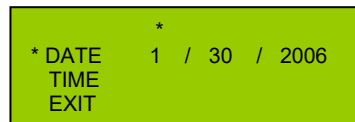

Arrow Up one number.

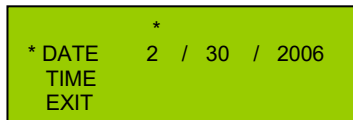

Enter

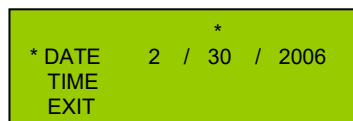

Continue with the sequence until the correct date appears. Then select Enter and the following will be displayed.

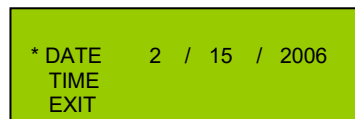

At this point the operator can advance to setting the correct time using the Down Arrow.

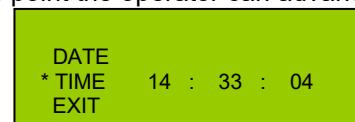

## SensAlert IR Transmitter

Time numbers are changed using the procedure as the Date numbers. Once the correct Time is programmed, select Enter and arrow down to Exit.



Select Enter



Selecting Enter again will return the SensAlert IR Transmitter to normal operation.

## 6.9. 4 – 20 MA CAL Menu

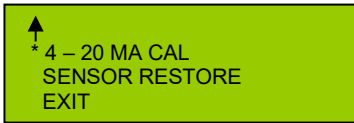

The 4 – 20 MA CAL Menu will allow the operator to increase or decrease the 4 to 20 mA output current at 4.0 mA and at 20 mA. *Typically, this menu is not often used in the field because the analog signals are set at the factory.*

Selecting Enter will display the following:

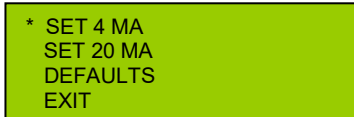

Selecting Enter will display the following:

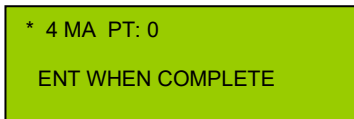

Using the UP / DOWN arrows will increase (UP arrow) or decrease (DOWN arrow) the number. Increasing the number will raise the 4.0 mA current output, lowering the number will decrease the 4.0 mA number. Note the number can be set to a negative number (-2 etc). Once the correct current output is set, pass the magnet over the ENTER Arrow and this will accept the new settings.

The display will be the following:

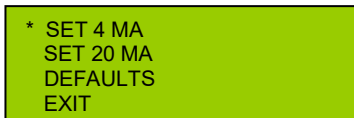

To adjust the full scale 20 mA current output arrow down and select ENTER:

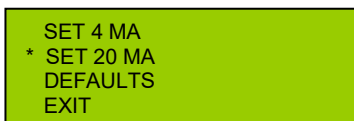

Using the UP / DOWN arrows will increase (UP arrow) or decrease (DOWN arrow) the number. Increasing the number will raise the 20.0 mA current output, lowering the number will decrease the 4.0 mA number. Note the number can be set to a negative number (-2 etc). Once the correct current output is set, pass the magnet over the ENTER Arrow and this will accept the new settings.

Arrow down to this display and select ENTER to clear all user set numbers. Both 4 MA and 20 MA will return to 0

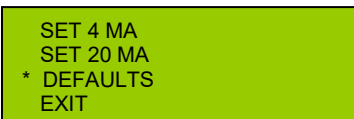

Arrow down and select Enter to return to the SensAlert IR Transmitter to 4-20 MA CAL main menu.

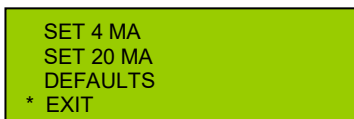

### 6.10. Sensor Restore Menu

```
4 – 20 MA CAL
* SENSOR RESTORE
EXIT
```

The SENSOR RESTORE menu will allow the user to restore the sensor to factory defaults. This is convenient if a user mis-calibrates a sensor and wants to revert to its original calibration. Refer to the table below for a list of Sensidyne products and software revisions that contain this function.

Product	Software Revision
Sensalert IR Sensor	27 or newer

Selecting Enter will display the following:

Selecting Enter will issue a factory restore and restore the sensor to its original factory settings. Any changes made to the zero, span, or calibration value will be reset. The SensAlert IR Transmitter will then

```
FACT RESET SENSOR
* YES
NO
```

show a SENSOR FAULT as the sensor must be reset for the factory restore to take effect. The sensor must then go through warmup again.

Arrow down from YES to NO to back out of the SENSOR RESTORE menu.

```
FACT RESET SENSOR
YES
* NO
```

## 7. DATA LOGGING (OPTIONAL)

The SensAlert IR Transmitter Unit provides event data logging to a flash card. The type of card used is MMC (MultiMedia Card). This flash card can be read by any personal computer that can read a FAT16 format file system, like cards from digital cameras and other portable devices. It should NEVER be formatted by a personal computer, rather be formatted by the SensAlert IR Transmitter unit itself under the Initial/Top Menu item "Format Flash Card". Data can be read directly from the flash card or copied to a personal computer. The file is a text file containing comma separated data values, one event per line. The text file will be the only file on the flash card, and currently will NOT be allowed to grow beyond 16MB (this is considered the memory card "full now" state). After the data is archived from the flash card, it can be re-formatted to start storage over. A flash card will typically not become full for many years.

### As The Memory Card Fills Up

When a flash card crosses 80% full (approximately 12 MB), the memory card status will change from "MC-OK" to "MC-FULL", warning the user to copy the contents off to a permanent storage location and reformat the card to start storage over. The SensAlert IR Transmitter will continue to log data to the flash card until it reaches 100% full. At that time, the status will change to "MC-FULLNOW" indicating that there is no more room to store data. At this point data storage has STOPPED and events may be lost that would otherwise be stored. If the card is removed and reinserted, the SensAlert IR Transmitter may eventually display the status as "MC-FAULT", indicating a memory card fault. The card MUST be formatted at this point.

### How Long It May Take to Fill a Memory Card

The shortest period to fill a memory flash data card is approximately 200 – 300 hours. To accomplish this, gas levels must be constantly changing beyond 5% of sensor range and alarm events and other related events must be persistently changing at a highly sustained rate. It is unlikely that this could ever happen under normal circumstances, since alarms would be sounding and intervention would be absolutely necessary. If sensor(s) are properly calibrated, and normal maintenance is performed, the memory card will probably not fill up for ten years or more. Since the operating environment determines the amount of data and frequency for storage, the time it takes to fill a data card will differ for each installation.

### Flash Card Removal and Formatting

Removing a data flash card should not occur without selecting the first Top Menu Item "Eject Flash Card". This prepares the flash card for removal by writing any data cached in memory out to the file system and ensures the file system on the data flash card is not corrupted. Formatting a data flash card allows the card to start over and re-capture space. Caution should be exercised to ensure that any data needed is archived first since this process will erase all data. The file system will be re-started and prepared as if from the factory. Just select the Menu Item on the second page of the Top Menu "Format Flash Card" to begin the process.

### Data Log File Contents

Events such as a 5% gas level change, alarm state change, sensor warm-up, calibration, system power on, sensor fault or parameter changes are logged and stored. Data from normal operation is NOT recorded when gas levels do not change beyond a 5% band. Here is the data log format:

**LOG FILE EVENT ENTRY FORMAT:**

tt,mm/dd/yyyy,HH:MM:SS,ID- vv

Where: tt = type, 00 - 99  
 mm = month, 1 - 12  
 dd = day, 1 - 31  
 yyyy = year, 2000 - 2099  
 HH = hours, 0 - 23  
 MM = minutes, 0 - 59  
 SS = seconds, 0 - 59  
 ID- = Sensor number (S1, S2 or BB for both)  
 vv = variable data depending on tt

**Log Entry Type Table (tt):**

Log Entry Type Code (tt)	Description
00	Boot/Power up- SensAlert IR Transmitter Unit Information Event
01	Sensor Warm-up: New Sensor/Sensor removed and replaced Event
02	Parameter Changes Made Event
03	Alarm High-Level Triggered Event
04	Alarm Mid-Level Triggered Event
05	Alarm Low-Level Triggered Event
06	Change in Gas Level > 5% of Sensor Range Event
07	Sensor Fault/Missing/Not Identical Detected Event
08	Sensor Calibrated Event
09	Flash Cleared/Restarted Event
10	Self-Test Initiated by Operator Event
11	Self-Test Concluded by Operator Event
12	Self-Test Aborted by Operator Event
13	Sensor Cell Warning Event
14	SensAlert IR Transmitter Unit Role Change Event
99	Flash Card Re-inserted Event

**Log Entry Data Format For Each Type Table (vv):**

Log Entry Type Code (tt)	Log Entry Event Name <i>Log Variable Data Format (vv)</i>
00	<b>SensAlert IR Transmitter Boot/Power Up Event</b> <i>Preamble,BB- US,FWVerMaj.Min.Rev</i>
01	<b>Sensor Warm-up Event</b> <i>Preamble,ID- US,FWVerMaj.Min.Rev</i>
02	<b>Parameters Changed Event</b> <i>Preamble,ID- NID,ZID,SSN,STP,CD,CV,RNG,LOW,MID,HI,GU,GN</i>
03	<b>Alarm High-Level Triggered Event</b> <i>Preamble,ID- Gas Value Float</i>
04	<b>Alarm Mid-Level Triggered Event</b> <i>Preamble,ID- Gas Value Float</i>

05	<b>Alarm Low-Level Triggered Event</b> <i>Preamble, ID- Gas Value Float</i>
06	<b>Change in Gas Level Event</b> <i>Preamble, ID- Gas Value Float</i>
07	<b>Sensor Fault Event</b> <i>Preamble, ID- (SSC, SEC)/SMT</i>
08	<b>Sensor Calibration Event</b> <i>Preamble, ID- CALTXT</i>
09	<b>Flash Cleared Event</b> <i>Preamble, BB- "Memory Card Cleared."</i>
10	<b>Self-Test Initiated Event</b> <i>Preamble, ID- "Self Test Started."</i>
11	<b>Self-Test Concluded Event</b> <i>Preamble, ID- "Self Test Concluded."</i>
12	<b>Self-Test Aborted Event</b> <i>Preamble, ID- "Self Test Aborted."</i>
13	<b>Sensor Cell Warning Event</b> <i>Preamble, ID- CWC</i>
14	<b>3100 Unit Role Change Event</b> <i>Preamble, BB- RLM, SHR</i>
99	<b>Flash Card Re-inserted Event</b> <i>Preamble, BB- US, DVID, FWMaj, Min. Rev, RLM, SHR</i> - S1: NID, ZID, SSN, STP, CD, CV, RNG, LOW, MID, HI, GU, GN - S2: NID, ZID, SSN, STP, CD, CV, RNG, LOW, MID, HI, GU, GN
<b>Parameter Variables:</b>	
<b>Variable</b>	<b>Variable Description</b>
<i>Preamble</i>	tt,mm/dd/yyyy,HH:MM:SS
tt	Log Entry Type Code
mm	Month value (01 – 12)
dd	Day of month (01 – 31)
yyyy	Year (2000 – 2099)
HH	Hours (24 hour format, 00 – 23)
MM	Minutes (00 – 59)
SS	Seconds (00 – 59)
S1-	Literal text for sensor one (S1-)
S2-	Literal text for sensor two (S2-)
BB-	Literal text for both sensors (BB-)
ID-	Replaced with literal text (S1-, S2- or BB-) based on sensor(s) reporting on
US	SensAlert IR Transmitter Unit Serial Number
DVID	Disk Volume ID
FWMaj	Firmware Major Version Number
Min	Firmware Minor Version Number

## SensAlert IR Transmitter

Rev	Firmware Revision Version Number
RLM	Relay Logic Mode (0 = first, 1 = second, 101 = AND, 102 = OR)
SHR	Sensor Head Role (0 = Identical, 1 = Unique, 2 = Single Sensor)
NID	Network ID
ZID	Network Zone ID
SSN	Sensor Serial Number
STP	Sensor Type Code (see sensor manual for codes)
CD	Sensor Last Calibration Date
CV	Calibration Value (Float)
RNG	Sensor Range Value (Float)
LOW	Alarm Low threshold Point (Float)
MID	Alarm Mid threshold Point (Float)
HI	Alarm High threshold Point (Float)
GU	Gas Units Name (4 text characters)
GN	Gas Name (8 text characters)
(SSC,SEC)/SMT	Either (Sensor Status Code, Sensor Error Code values) OR Sensor Fault Message Text
SSC	Sensor Status Code (see sensor manual for code values)
SEC	Sensor Error Code (see sensor manual for code values)
SMT	Literal text: "Sensor Missing!", or "Sensors Not Identical!"
CALTXT	Literal text: "Zeroed." or "Spanned."

## **8. FIGURES**

**Figure 1 – Overall Layout**

**Figure 2 – Back View of SensAlert IR Transmitter Wiring**

**Figure 3 – SensAlert IR Sensor Separation Kit**

**Figure 4 – Mounting SensAlert IR Transmitter and SensAlert IR Sensor**

**Figure 5 – Mounting SensAlert IR Transmitter and SensAlert IR Sensor Tall**

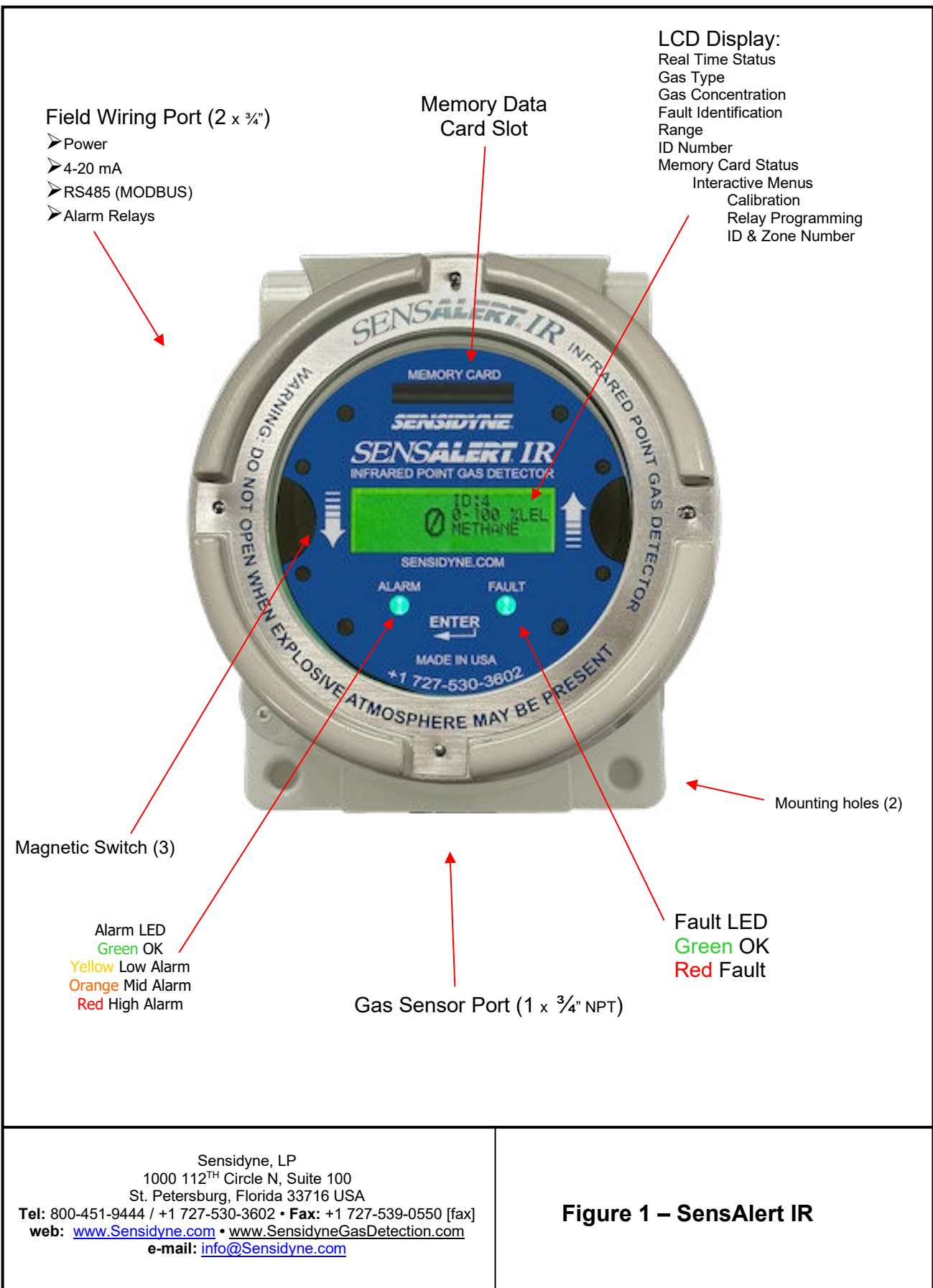

Field Wiring Port (2 x 3/4")

- Power
- 4-20 mA
- RS485 (MODBUS)
- Alarm Relays

Memory Data Card Slot

LCD Display:

- Real Time Status
- Gas Type
- Gas Concentration
- Fault Identification
- Range
- ID Number
- Memory Card Status
- Interactive Menu
- Calibration
- Relay Programming
- ID & Zone Number

Magnetic Switch (3)

Alarm LED

- Green OK
- Yellow Low Alarm
- Orange Mid Alarm
- Red High Alarm

Mounting holes (2)

Fault LED

- Green OK
- Red Fault

Gas Sensor Port (1 x 3/4" NPT)

Sensidyne, LP  
 1000 112<sup>TH</sup> Circle N, Suite 100  
 St. Petersburg, Florida 33716 USA  
 Tel: 800-451-9444 / +1 727-530-3602 • Fax: +1 727-539-0550 [fax]  
 web: [www.Sensidyne.com](http://www.Sensidyne.com) • [www.SensidyneGasDetection.com](http://www.SensidyneGasDetection.com)  
 e-mail: [info@Sensidyne.com](mailto:info@Sensidyne.com)

Figure 1 – SensAlert IR

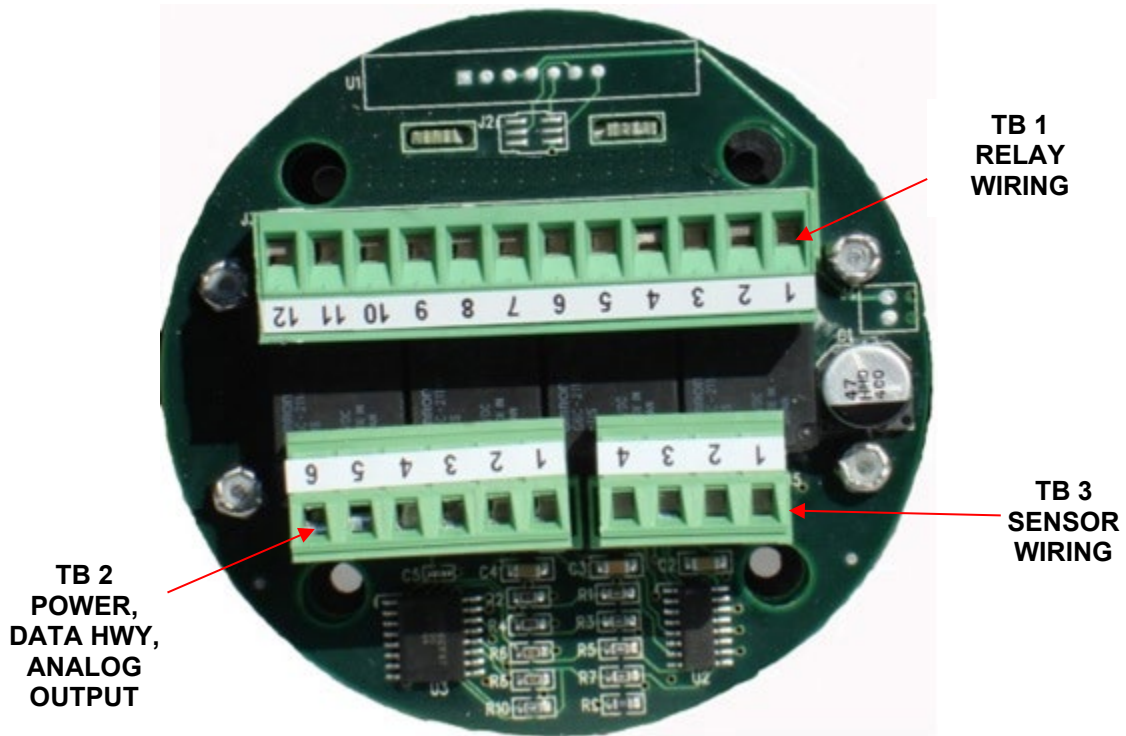

- TB 1**
- (12) LOW ALARM N.C.
  - (11) LOW ALARM COMMON
  - (10) LOW ALARM N.O.
  - (9) MID ALARM N.C.
  - (8) MID ALARM COMMON
  - (7) MID ALARM N.O.
  - (6) HIGH ALARM N.C.
  - (5) HIGH ALARM COMMON
  - (4) HIGH ALARM N.O.
  - (3) FAULT (N.E.) N.C.
  - (2) FAULT (N.E.) COMMON
  - (1) FAULT (N.E.) N.O.

- TB 2**
- (1) 4-20 mA ANALOG OUTPUT
  - (2) DC COMMON
  - (3) +24 VDC
  - (4) DATA ISO COMMON
  - (5) RS485 DATA B
  - (6) RS485 DATA A

- TB 3**
- (1) WHITE (DATA/CAL)
  - (2) BLUE OR GREEN (4-20 mA)
  - (3) RED (+24 VDC)
  - (4) BLACK (DC COMMON)

NC = NORMALLY CLOSED  
 NO = NORMALLY OPEN

Sensidyne, LP  
 1000 112<sup>TH</sup> Circle N, Suite 100  
 St. Petersburg, Florida 33716 USA  
 Tel: 800-451-9444 / +1 727-530-3602 • Fax: +1 727-539-0550 [fax]  
 web: [www.Sensidyne.com](http://www.Sensidyne.com) • [www.SensidyneGasDetection.com](http://www.SensidyneGasDetection.com)  
 e-mail: [info@Sensidyne.com](mailto:info@Sensidyne.com)

**Figure 2 - Back View of SensAlert IR Wiring**

SensAlert IR Transmitter

	Black	Red	Blue	White	Yellow	Brown
SensAlert IR Transmitter	1	2	4	5	N/A	N/A
SensAlert IR Sensor	1	2	4	5	N/A	N/A
	-	+	Analog Out	Comm	Analog Out	Pressure Comp

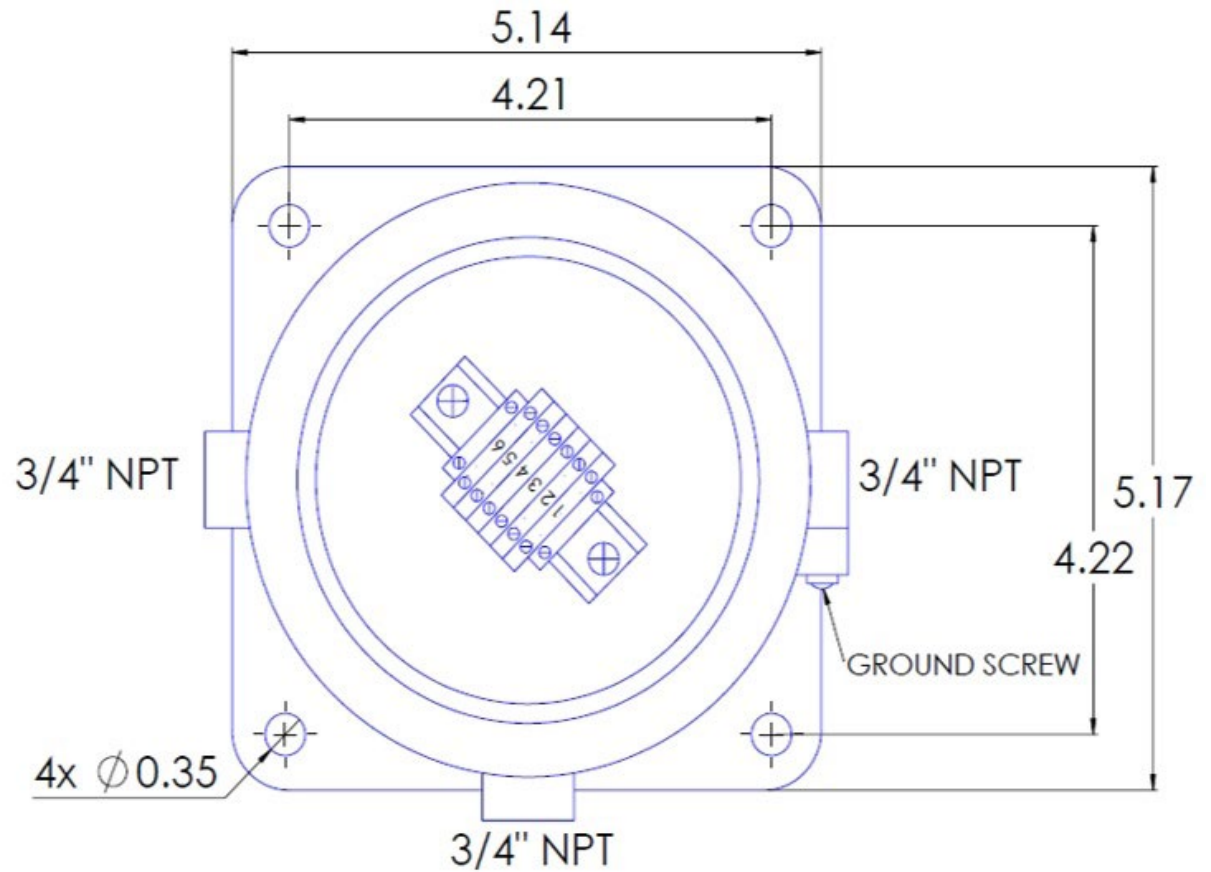

- NOTES:  
Class I, Div I Group B, C & D  
Ex d IIC GB
- TERMINALS: 6
- HEIGHT: 4.11" COVER INSTALLED
- GROUND SCREW ALSO LOCATED UNDER TERMINAL BLOCK

Figure 3 – SensAlert IR Sensor Separation Kit

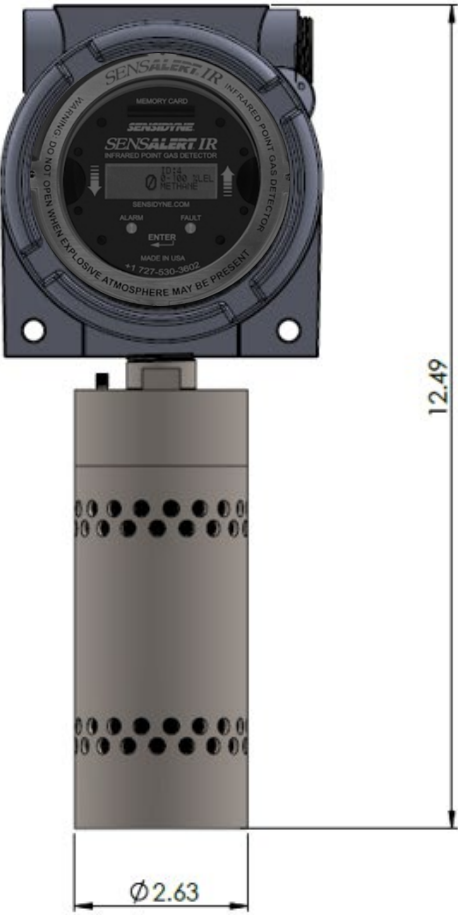
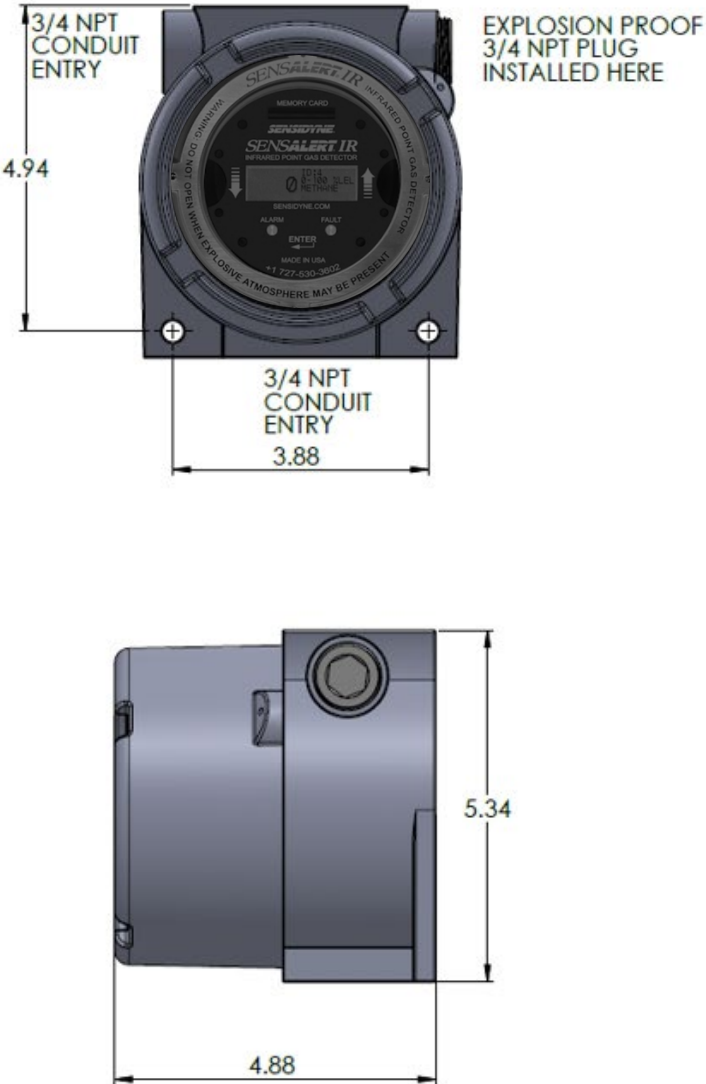

Figure 4 - Mounting SensAlert IR Transmitter and SensAlert IR Sensor

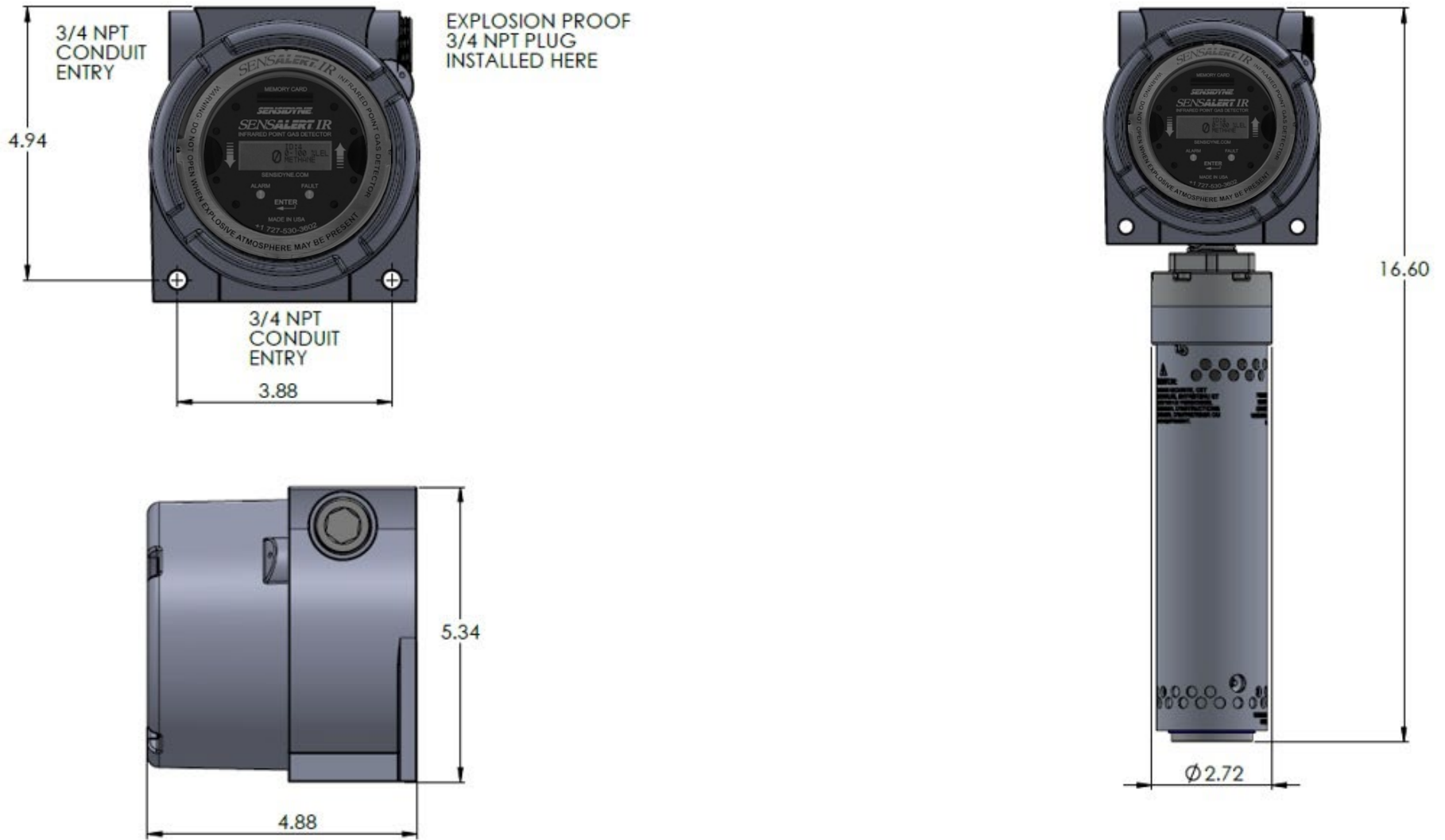

Figure 5 - Mounting SensAlert IR Transmitter and SensAlert IR Sensor Tall

## 9. UNIT STATUS FLASH CODES

Flash Rate	Output Current	PC Reads (Hex)	Status Code (Dec)	Unit Status Label	Description
1	4-20ma	0x00	0	Unit Running	Unit is measuring gas and adjusting 4-20ma output accordingly.
2	2.2ma	0x02	2	Unit Zero Calibrating	Unit goes through its <i>zero calibration</i> procedure.
3	2.0ma	0x03	3	Unit Spanning	Unit goes through its <i>spanning</i> procedure.
4	0-20ma	0x04	4	Unit 4-20ma Calibrating	Unit goes through its <i>4-20ma-calibration</i> procedure. (Factory Only)
5	0.8ma	0x05	5	Unit Warm-up	Unit is warming up.
6	0.0ma	0x06	6	Power-up Fault	Unit has determined a <i>Power-Up</i> fault condition.
7	1.6ma	0x07	7	Calibration Fault	Unit has determined an error during <i>calibration</i> procedure.
8	NA	0x08	8	NA	Currently Not Used
9	0.0ma	0x09	9	Unit Fault	Unit has determined a <i>Unit_Fault</i> condition.
10	1.0ma	0x0a	10	Optics Fault	Unit has determined an <i>Optics_Fault</i> condition.
11	1.2ma	0x0b	11	Zero Drift Fault	Unit has determined a <i>Zero_Drift_Fault</i> condition.
12	0.0ma	0x0c	12	Configuration Fault	Unit has never been <i>Zeroed, Spanned, Source</i> calibrated, or E <sup>2</sup> has a Header byte error.
13	1.4ma	0x0d	13	Hot Zero Calibration	Unit goes through its <i>Hot Temperature calibration</i> procedure. (Factory Only)
14	1.4ma	0x0e	14	Cool Zero Calibration	Unit goes through its <i>Cool Temperature calibration</i> procedure. (Factory Only)
15	4mA->20mA	0x0f	15	Self Test	Unit generates zero to full scale output (4-20mA & Norm Gas Level)
16	0.2ma	0x10	16	Reference Channel Fault	AGC Potentiometer reaches the minimum predetermined value during the unit AGC procedure.

SensAlert IR Transmitter

17	0.4ma	0x11	17	Active Channel Fault	Balance Potentiometer reaches the minimum or maximum predetermined value during the unit Calibration procedure.
18	N/A	0x12	18	Power Fault	24VDC < 18 or 24VDC >32V
19	N/A	0x13	19	Comp Zeroing	
20	N/A	0x14	20	Comp Spanning	
21	N/A	0x15	21	Fixed 4mA	
22	N/A	0x16	22	Fixed 20mA	

## 10. UNIT ERROR CODES

Error Code Label's	Error Code Value's	Error Code (Dec)	Error Code Description's	Unit Status
NO_ERROR	0x00	0	Unit is measuring gas and operating properly	Unit Running
ERR_EEPROM_HEADER_BYTE	0x01	1	EEPROM does not have correct header byte stored.	Configuration Fault
ERR_EEPROM_CHKSUM	0x02	2	Checksum byte from EEPROM does not match calculated checksum on latest EEPROM read.	Configuration Fault
ERR_NO_ZERO_YET	0x03	3	Unit has yet to be zero calibrated.	Configuration Fault
ERR_NO_SPAN_YET	0x04	4	Unit has yet to be spanned.	Configuration Fault
ERR_ZERO_VALUES	0x05	5	Zero values are out of specification limits.	Power-up Fault
ERR_420_CALIB1	0x06	6	When searching for >4vdc level during the 4-20ma calibration procedure, it was unsuccessful in the first three attempts.	Power-up Fault
ERR_420_CALIB2	0x07	7	When searching for the exact 4vdc level during the 4-20ma calibration procedure, it was unsuccessful in the first four attempts.	Power-up Fault
ERR_SIGNAL_HIGH	0x08	8	When the signal level is greater than 4.75vdc at the time it is read during the AGC procedure.	Zero Drift Fault
ERR_4VDC_REF_LOW	0x09	9	When the internal reference voltage is too low.	Unit Fault
ERR_4VDC_REF_HIGH	0x0A	10	When the internal reference voltage is too high.	Unit Fault
ERR_BAL_POT_MAX	0x0B	11	When the Balance digital potentiometer reaches the maximum predetermined value during the unit calibration procedure.	Calibration Fault
ERR_BAL_POT_MIN	0x0C	12	When the Balance digital potentiometer reaches the minimum predetermined value during the unit calibration procedure.	Calibration Fault

SensAlert IR Transmitter

ERR_AGC_POT_MAX	0x0D	13	When the AGC digital potentiometer reaches the maximum predetermined value during the unit AGC procedure.	Optics Fault
ERR_AGC_POT_MIN	0x0E	14	When the AGC digital potentiometer reaches the minimum predetermined value during the unit AGC procedure.	Ref Channel Fault
ERR_SPAN_POT_MAX	0x0F	15	When the Span digital potentiometer reaches the maximum predetermined value during the unit span procedure.	Calibration Fault
ERR_SPAN_POT_MIN	0x10	16	When the Span digital potentiometer reaches the minimum predetermined value during the unit span procedure.	Calibration Fault
ERR_NO_HOT_ZERO_YET	0x11	17	Unit has yet to be zeroed while Hot.	Configuration Fault
ERR_NO_COOL_ZERO_YET	0x12	18	Unit has yet to be zeroed while Cool.	Configuration Fault
ERR_UNIT_TEMP_HIGH	0x13	19	Unit Temperature is over the specified upper limit.	Unit Fault
ERR_UNIT_TEMP_LOW	0x14	20	Unit Temperature under the specified lower limit.	Unit Fault
ERR_ANALYTICAL_RANGE	0x15	21	Insufficient Analog Range during spanning	Calibration Fault
ERR_NO_TABLE_YET	0x16	22	Unit has yet to down load a table via the PC and Comm_Link.	Configuration Fault
ERR_SPAN_NO_LONGER_VALID	0x17	23	Range has been changed	Cal Fault
ERR_SPAN_POT_OVERFLOW	0x18	24	Not enough Span pot room for temperature comp. (Span Gain too high)	Cal Fault
ERR_24VDC_LOW	0x19	25	24VDC too Low	Unit Fault
ERR_24VDC_HIGH	0x1A	26	24VDC too High	Unit Fault
PRESSURE_FAULT	0x1B	27	No Pressure Sensor Input	Unit Fault
FAULT_EXTERNAL	0x1C	28	LIM (Fault Version) Either input Active...External Fault Condition	Unit Fault

ERR_RD_PRES	0x1D	29	SensAlert IR Sensor. No response from MPL115A2	Unit Fault
-------------	------	----	--	------------

### Warnings

High Level Interfering Gas	0x84	132	SensAlert IR Sensor	Run (Warning)
Slave Not Found	0x85	133	SensAlert IR Sensor	Run (Warning)
Calibration Needed	0x88	136	SensAlert IR Sensor	Run (Warning)
Temp Transient	0x8A	138	SensAlert IR Sensor	Run (Warning)
EOL Warning	0x8B	139	SensAlert IR Sensor has reached its end of life	Run (Warning)
Over-Range	0x8C	140	SensAlert IR Sensor gas output over predetermined range	Run (Warning)

Revision	Description
A	Initial Release
-	-

***SENSIDYNE***<sup>®</sup>

Sensidyne, LP

1000 112<sup>th</sup> Circle N, Suite 100

St. Petersburg, Florida 33716 USA

800-451-9444 • +1 727-530-3602 • +1 727-539-0550 [fax]

web: [www.sensidyne.com](http://www.sensidyne.com) • e-mail: [info@sensidyne.com](mailto:info@sensidyne.com)