

# ***SENSALERT IR***

## **Transmitter – Dual-Sensor**



## **Instruction and Operation Manual**

**Document No. 360-2001-02 Rev A**

### ***SENSIDYNE***

Sensidyne, LP • 1000 112<sup>th</sup> Circle N, Suite 100  
St. Petersburg, Florida 33716 USA  
800-451-9444 • +1 727-530-3602 • +1 727-539-0550 [fax]  
web: [www.sensidyne.com](http://www.sensidyne.com) • e-mail: [info@sensidyne.com](mailto:info@sensidyne.com)



## Sensidyne, LP

Sensidyne, LP designs and manufactures innovative fixed system gas detection equipment, for combustible gases, oxygen, carbon dioxide and toxic gases.

### Commitment

Our quality and service are uncompromising. We back the SensAlert IR with a five-year warranty on all materials and workmanship. We offer technical support, user training and on-site service and maintenance of equipment to meet the needs of our customers.

### Gas Detection Service

Individually designed maintenance packages are available for specific customer needs. Service begins with verification of the system installation that includes an initial system check and calibration. We then offer customer training programs (on-site and at factory) to ensure that technical personnel fully understand operation and maintenance procedures. When on-the-spot assistance is required, service representatives are available to handle any questions or problems immediately.

### WARRANTY

**SENSIDYNE, LP WARRANTS SENSALERT IR PROVIDED BY SENSIDYNE TO BE FREE FROM DEFECTS IN WORKMANSHIP AND MATERIALS FOR A PERIOD OF FIVE (5) YEARS FROM DATE OF SHIPMENT FROM THE FACTORY. ANY PARTS RETURNED FREIGHT PRE-PAID TO THE FACTORY AND FOUND DEFECTIVE WITHIN THE WARRANTY WOULD BE REPAIRED OR REPLACED, AT SENSIDYNE OPTION. SENSIDYNE WILL RETURN REPAIRED OR REPLACED EQUIPMENT PRE-PAID LOWEST COST FREIGHT. THIS WARRANTY DOES NOT APPLY TO ITEMS, WHICH BY THEIR NATURE ARE SUBJECT TO DETERIORATION OR CONSUMPTION IN NORMAL SERVICE.**

**WARRANTY IS VOIDED BY ABUSE INCLUDING ROUGH HANDLING, MECHANICAL DAMAGE, ALTERATION OR REPAIR. THIS WARRANTY COVERS THE FULL EXTENT OF SENSIDYNE LIABILITY AND SENSIDYNE IS NOT RESPONSIBLE FOR REMOVAL, REPLACEMENT COSTS, LOCAL REPAIR COSTS, TRANSPORTATION COSTS OR CONTINGENT EXPENSES INCURRED WITHOUT PRIOR WRITTEN APPROVAL. SENSIDYNE OBLIGATION UNDER THIS WARRANTY SHALL BE LIMITED TO REPAIR OR REPLACEMENT OF ANY PRODUCT THAT HAS BEEN RETURNED TO SENSIDYNE FOR WARRANTY CONSIDERATION. THIS WARRANTY IS EXPRESSLY IN LIEU OF ANY AND ALL OTHER WARRANTIES EXPRESSED OR IMPLIED, AND ALL OTHER OBLIGATIONS OR LIABILITIES ON THE PART OF SENSIDYNE INCLUDING BUT NOT LIMITED TO, THE FITNESS FOR A PARTICULAR PURPOSE. IN NO EVENT SHALL SENSIDYNE BE LIABLE FOR DIRECT, INCIDENTAL, OR CONSEQUENTIAL LOSS OR DAMAGE OF ANY KIND CONNECTED WITH THE USE OF IT'S PRODUCTS OR FAILURE TO FUNCTION OR OPERATE PROPERLY.**

### CONVENTIONS

The following conventions are used in this manual.



Warning Statement – Consult this manual when this symbol is found on the product or in any related documentation.



VDC (DC Voltage)

AC



or DC Voltage

# 1. TABLE OF CONTENTS

1.	TABLE OF CONTENTS.....	4
2.	GENERAL DESCRIPTION.....	5
3.	APPROVALS / CERTIFICATIONS .....	5
4.	SPECIFICATIONS .....	5
4.1.	Mechanical .....	6
4.2.	Electrical.....	7
5.	UNIT INSTALLATION .....	8
6.	OPTIONAL FEATURES.....	10
6.1.	Relay Option.....	10
6.2.	Data Card Option .....	10
6.3.	Heater Option .....	10
7.	USER INTERFACE .....	12
8.	INITIAL STARTUP .....	13
9.	NORMAL OPERATION .....	15
10.	SETUP – CONFIGURATION OPERATION .....	16
10.1.	Required Sequence for Changes to Configuration .....	16
10.2.	Date and Time.....	16
10.3.	Relay Settings – Latching, Delay and Control Logic.....	19
10.3.1.	Resetting Latched Relays .....	22
10.4.	Sensor Mode – Single, Unique, or Identical.....	22
10.5.	Alarm Settings – Threshold Values and Active Mode.....	25
10.6.	Network ID (Sensor / Display Network Identities).....	26
10.7.	Modbus Settings .....	29
11.	SENSOR CALIBRATION.....	33
11.1.	Zero Cal.....	33
11.2.	Span Cal (and Calibration Value).....	35
11.3.	Factory Restore.....	37
12.	DIAGNOSTIC FUNCTIONS .....	38
13.	SELF-TEST MENU .....	39
14.	INFO MENU CONTENTS .....	40
15.	HIDE LOW GAS .....	41
16.	DATA LOGGING (OPTIONAL).....	42
16.1.	Formatting the Flash Card (Selected from the Initial / Top Menu, Page 2) .....	45
17.	UL 2075 EOL (END-OF-LIFE) NOTIFICATION.....	46
18.	FIGURES.....	47
19.	UNIT STATUS FLASH CODES .....	53
20.	UNIT ERROR CODES .....	55

## 2. GENERAL DESCRIPTION

### SENSALERT IR Dual-Sensor Display

The SensAlert IR Dual transmitter is designed to interface with two sensors and can be used with the SensAlert IR Sensor

The SensAlert IR is a multi-microprocessor based intelligent transmitter continuously monitoring information from the gas sensor(s). The LCD of the SensAlert IR displays the gas concentration(s) and sensor status(s). The SensAlert IR has one (1) "Alarm" LED and one (1) "Status" LED. The SensAlert IR also has three (3) magnetic switches located around the circumference of the unit. This manual will describe the operation and use of the SensAlert IR Transmitter.

### Features

- *Explosion Proof*
- *Back lighted LCD Display*
- *Low Cost*
- *Plug and play infrared gas sensors*
- *Self-check system*
- *4-20 mA sensor pass-thru output*
- *RS-485 Interface (Isolated), as a Modbus RTU Slave*
- *Optional alarm and fault relays*
- *Optional LCD heater for cold applications*
- *Optional Data card for datalogging*
- *Non-intrusive programming*
- *Non-intrusive calibration*
- *Removable, non-volatile, time stamped data logging*
- *Digital communication link to SensAlert IR Gas Sensors*
- *Multi-port housing for easy installation*
- *2 Inputs for 2 SensAlert IR Sensors*

## 3. APPROVALS / CERTIFICATIONS

North American (c/us) Certificate:	Class I, Division 1, Groups B, C, D, T5 Class I, Zone 1, AEx d IIC Gb
------------------------------------	--

The SensAlert IR is approved to the standards shown in the approvals certificates. To maintain compliance with these standards, install the SensAlert IR per the following instructions and precautions.

## 4. SPECIFICATIONS

The following specifications are for the SensAlert IR Transmitter only. Consult the appropriate sensor manuals for their specifications.

### For use with (up to two):

- SensAlert IR Sensors

**Environmental:**

The SensAlert IR Dual Transmitter can be installed in indoor, outdoor, and wet locations. The housings have ingress protection ratings of IP66. Pollution degree 2 and Overvoltage category II

Operating Temperature (Ta) and Humidity Rating:

-40° to +40°C (-40 to +104° F) when equipped with the optional LCD heater

0° to +40°C (32° to +104°F) when not equipped with the LCD heater.

The unit will operate below this temperature, but at a reduced function, specifically the LCD may become illegible or damaged.

0 to 99% RH (non-condensing)

Altitude / Elevation:

IEC 61010-1 certified to 2000 meters.

**4.1.Mechanical**

**Construction:**

Epoxy Coated Aluminum

Dimensions: (See Figure 4 & 5 for details)

Height: 5 Inches (128 mm)

Width: 5 inches (128 mm)

Depth: 4.8 inches (122 mm)

Weight: (2.8 kg)

Conduit Entry:

Three (3) 3/4 inch NPT



For hazardous location installations seals must be installed within 18 inches of conduit entries.

## 4.2. Electrical

### Mains Supply (Operating Voltage):

24 VDC  $\overline{\overline{\overline{\quad}}}$  Nominal (Range: 18 to 32 Vdc) measured at the detector head

Current Draw: (without sensors)

Average: 250 mA (Peak: 500 mA)

### Input, Sensor (Digital):

0-5 V, Sensidyne, LP Proprietary, Single-Wire, Digital signal from the sensor.

This signal is used by the sensor to communicate status and gas data and is used by the display to initiate sensor calibration and query status.

### Output (Analog):

4-20 mA (Source Type), max 1000 ohm load at 24 Vdc supply voltage.

The 4-20 mA output is provided by the sensor and is passed through the SensAlert IR Transmitter.

The transmitter can be located at any point in the sensor's output loop. Consult the appropriate sensor manual for 4-20 installation requirements.

### Output (Digital):

RS485 LAN (isolated) MODBUS RTU Slave, compatible with Modicon Modbus Specification PI-MBUS-300 Rev. J. Refer to SensAlert IR Dual Transmitter Modbus Technical Sheet for specific configuration and use information.

### Output (Relays):

Three (3) Alarms: Low, Mid High. One (1) Fault

Rated for 8 Amps, 30 VDC or 120VAC  $\overline{\overline{\quad}}$

### Real Time Clock Battery:

The SensAlert IR uses a real time clock that runs on a 3V, 1220 battery.

## 5. UNIT INSTALLATION



**Warning** – If the equipment is used in a manner not specified by the manufacturer, the protection provided by the equipment may be impaired.



**Warning** – Do not open when energized or when an explosive atmosphere is present.



**AVERTISSEMENT - GARDER LE COUVERCLE BIEN FERME TANT QUE LES CIRCUITS SONT SOUS TENSION**

### Device Location:

The first step in the installation process is to establish a mounting location for the SensAlert IR Transmitter and Sensor(s). The most effective number and placement of sensors vary depending on the conditions of the application. Select a sensor location that is typical of the atmosphere to be monitored or close to the anticipated source of a dangerous gas. When determining where to locate gas sensors the following factors should be considered.

- What are the characteristics of the gas that is to be detected? Is it lighter or heavier than air? If it is lighter than air the sensor should be placed above the potential gas leak. Place the sensor close to the floor for gases that are heavier than air. Note that air currents can cause a gas that is heavier than air to rise. In addition, if the temperature of the gas is hotter than ambient air or mixed with gases that are lighter than air, it could also rise.
- How rapidly will the gas diffuse into the ambient air? Select a location for the sensor that is close to the anticipated source of a gas leak.
- Wind or ventilation characteristics of the immediate area must also be considered. Movement of air may cause gas to accumulate more heavily in one area than in another. The detector should be placed in the areas where the most concentrated accumulation of gas is anticipated. For outdoor applications with strong wind conditions, it may require the sensors to be mounted closer together and on the downwind side, to the anticipated area of a gas leak. Also take into consideration for indoor applications, the fact that many ventilation systems do not operate continuously.
- The sensor(s) should be accessible for maintenance.
- Excessive heat or vibration can cause premature failure of any electronic device and should be avoided if possible.
- Follow all national and local installation codes and practices.

When installing, make sure power is off when connecting the sensor, field, and relay wiring to the appropriate terminal blocks. DO NOT turn the power back on until the SensAlert IR is secured to the housing using all four hex head screws.

### Mounting:

Mount the SensAlert IR Transmitter to rigid wall (wood based or stronger) or bulkhead structures using 1" or longer fasteners with a minimum 3/16" diameter. Mounting unit to drywall (wallboard, plasterboard, etc.) or similar material is not recommended.

**1Wiring:**

Wire insulation for relay contacts should have a minimum breakdown voltage of twice that of the working voltage of the signal. E.g., 110v lines should have a minimum insulation breakdown voltage of 220v, 240v signals should have a minimum insulation breakdown voltage of 480v.

Wire insulation should be temperature rated for greater than 100°C.

Use copper conductors only on all terminal blocks.

Wire Sizing (Power):

0 to 500 feet wire length; recommend wire gauge size 16 AWG

501 to 1000 feet wire length; recommend wire gauge size 14 AWG

**Safety Interrupt (mains circuit breaker):**

A circuit breaker or interrupt switch for overcurrent protection rated for 30 watts located in the mains supply circuit is recommended. It should be located near the device it is protecting and labeled.

To minimize the length of exposed conductor, strip wires to 3/8 inch. Tin the exposed wire with solder to increase durability.



Protective bonding is provided by an internal screw location for connection of a grounding wire. Installation of this wire should include the use of a locking feature (i.e., locking washer).

**Conduit:**

<sup>1</sup>For hazardous location installations seals must be installed within 18 inches of conduit entries.

The SensAlert IR Transmitter has three (3) 3/4" NPT threaded ports for mounting and wiring the sensor(s) and transmitter into a permanent installation. All 3/4 NPT threads must pass L1 thread/plug gauge. Field wiring connections are made on the backside of the SensAlert IR printed circuit assembly (PCA). For connection details refer to Figure 2.

Shielded cable is recommended. Wiring should be installed in metal conduit with no other cabling in the same conduit.

**Power Supply:**

The SensAlert IR Transmitter must be powered using a power supply rated for CAN/CSA C22.2 No. 61010-1-12 and ANSI/UL 61010-1 OR a class 2 power supply as defined in Canadian Electrical Code C22.1 Section 16-200 and/or National Electrical Code article 725.121.

Refer to IEC 60079-29-2 for guidance on safe installation, use, and maintenance of this equipment.

## 6. OPTIONAL FEATURES

The SensAlert IR Transmitter offers 3 options. A relay option for signaling alarm/faults, a data card option for logging gas occurrences, alarms/faults, and an LCD heater option for applications where the temperature goes below 2°C.

### 6.1. Relay Option

The SensAlert IR Transmitter offers an option for 3 alarm relays (low, mid, and high) and one fault relay. These relays are rated for 8 Amps 30 VDC/250 VAC.

When the transmitter sees that the gas concentration of the sensor has exceeded the low, mid, or high threshold, the low, mid, and/or high relay will be toggled on.

If the transmitter sees that the sensor is in a fault or has become disconnected, the fault relay will toggle. For more information on the different ways the relays can be configured, see Section 10.3 “Relay Settings”.

### 6.2. Data Card Option

The Data Card Option of the SensAlert IR uses a MMC card to log different events to help track and changes or sensor behavior. See below for events that get logged:

1. **Gas Change Events-** When a gas level rises or falls according to a pre-determined delta (change) threshold, a gas record is entered into the log by the SensAlert IR, containing the timestamp and gas level at the time of the event.
2. **Alarm Events-** When a gas level rises and triggers one of the alarms (low, medium, high) or when a sensor fault is detected, an alarm event is recorded along with a timestamp, the alarm type, and the gas level at the time of the event.
3. **Calibration Events-** When the user performs a calibration operation, a timestamp and calibration indicator is recorded.
4. **Parameter Change Events-** When the user changes settings on the SensAlert IR, a change event recorded is recorded along with a time stamp and the SensAlert IR parameters.
5. **Sensor Warm-up Events-** When either the SensAlert IR Transmitter or a Sensor is replaced and enters the warm-up operation, a sensor warm-up event is entered along with a timestamp and all the new sensor and SensAlert IR Transmitter parameters.
6. **Memory Card Events-** Whenever the Memory Card is removed or inserted, this event is recorded in the log along with all sensors, SensAlert IR Transmitter, and card unit serial number parameters to indicate a possible change in SensAlert IR Transmitter unit data, to help prevent confusion from different SensAlert IR Transmitter units using the same Memory Card at different times.

### 6.3. Heater Option

A heater option is available for SensAlert IR Transmitters that are going into cold climates. This is a closed loop heater that heats the LCD screen. It will turn on when the temperature drops below approximately 2°C and will turn off when the temperature rises above approximately 3°C.

This option ensures that the LCD will be readable, even at cold temperatures.

To conform to the performance standard 60079-29-1, the unit must have all 3 features and be used with the SensAlert IR Sensor 0-100%LEL Methane gas detector.

For more information regarding any features, contact Sensidyne.

## 7. USER INTERFACE

### User Inputs – Magnetic Switches:

The SensAlert IR Transmitter has three (3) magnetic switch pickups on the Display PCA. The picture below shows the locations of the magnetic switches labeled UP, DOWN and ENTER. Placing a magnet near one of the switches will cause the following operations to occur.

Switch	Operation
ENTER	Enter Menu Mode, Selects a menu to Enter
UP	Moves up through Menu selections
DOWN	Moves down through Menu selections

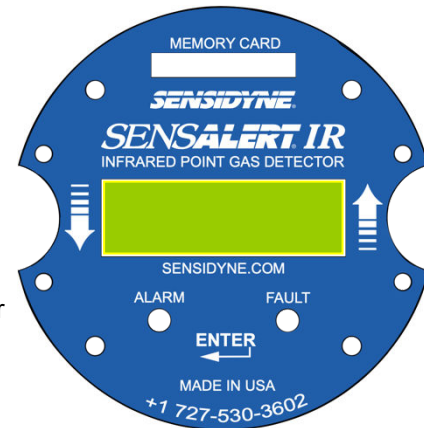

### LED Indicators:

There are two multi-color LEDs that indicate Alarm and Fault status. The Alarm LED indicates the current alarm status individually for each sensor, regardless of the Relay Mode. The alarm state LEDs toggle indication for each sensor along with the sensor information display. When sensor one information is displayed, the alarm-state LEDs indicate the alarm status for sensor one. When sensor two's information is displayed, the alarm-state LEDs indicate the alarm status for sensor two. The color of the Alarm LED indicates the Alarm level; **Low Alarm = Yellow, Mid = Amber and High = Red**. The fault state LED toggles with the sensor information display as well, except when a SensAlert IR Transmitter fault exists. In fault condition, this LED is Red.

### LCD Screen:

The LCD screen is a grayscale display with a 5/8 inch by 2-inch viewing area. It displays the gas type, range, measured gas concentration and status information for each sensor and the display unit. It has a contrast potentiometer that is accessible behind the faceplate on the Display PCB positioned just above the LCD display. The front faceplate must be removed to access it. This potentiometer allows the user to increase or decrease the display contrast, making it more visible under varying ambient light conditions and personal user preference.

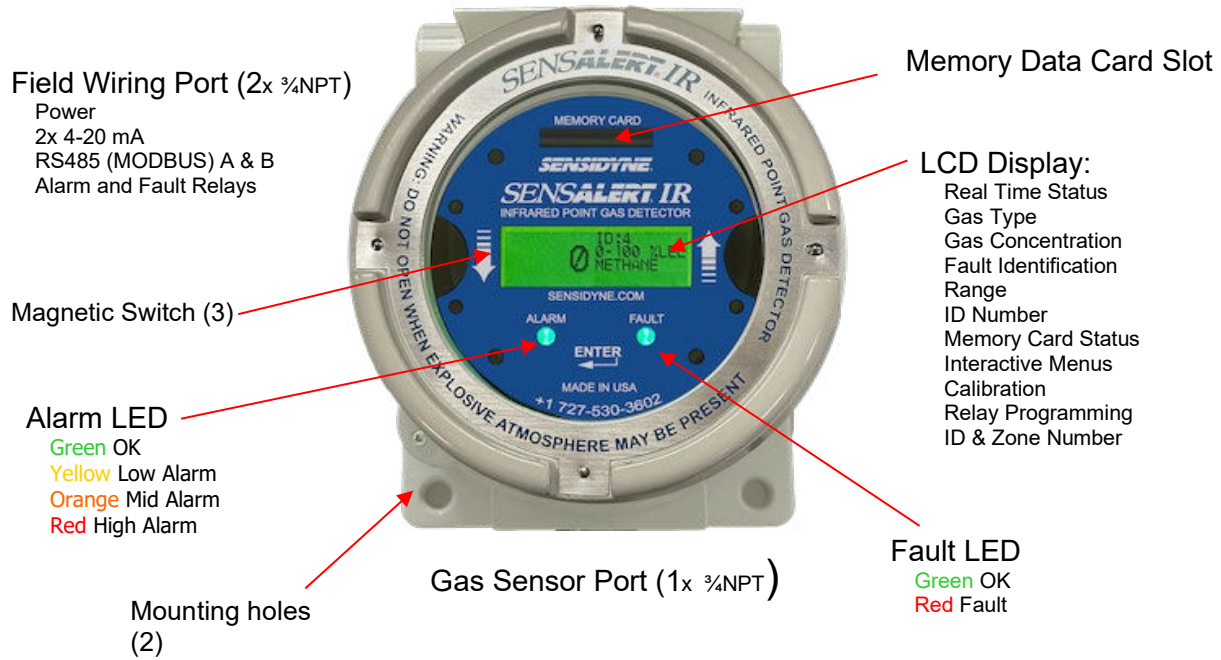

## 8. INITIAL STARTUP

When power is applied to the SensAlert IR Transmitter, it enters its power up sequence (approximately sixty seconds), followed by the sensor warm-up mode which can take between one and five minutes depending on the sensor(s). At the end of the warm-up period with no faults present, the SensAlert IR Transmitter automatically enters the normal operating mode.

If a fault is present after warm-up, the LCD and the Fault LED will indicate the fault. See your specific sensor's manual for warm-up and fault current value meanings (less than 4 mA).

**NOTE: If the SensAlert IR Transmitter is set to operate two sensors in the 'Identical' Role and they are not identical in gas type, range, or units, then the SensAlert IR Transmitter will display a fault and indicate that the *Sensors Are Not Identical*, and the fault relay on the SensAlert IR Transmitter will be engaged.**

### Initial Power Up Screen Sequence of the SensAlert IR

<p>SensAlert IR TRANSMITTER -STARTING UP FROM BRWN (SOFT RESET) 005</p>	<p>'BRWN' – Brown Out Reset (or 'SOFT RESET' shown on bottom line for a software reset) '005' – Counts down to '000' second startup delay</p>
<p>SensAlert IR TRANSMITTER VER X.YY.RRRR 005 08/10/2010 21:15:33</p>	<p>'VER' refers to the Firmware version installed in the display.</p>
<p>SensAlert IR TRANSMITTER VER X.YY.RRRR 003 -INIT ROM FROM RAM</p>	<p>'INIT ROM FROM RAM' – permanent parameters transferred from either 'ROM' to NVRAM or from NVRAM to ROM, or 'ROM' and 'RAM' are 'IDENTICAL'.</p>
<p>SensAlert IR TRANSMITTER VER X.YY.RRRR -BOOT SENSOR SYSTEM</p>	<p>'BOOT SENSOR SYSTEM' – Starting up sensor controllers</p>
<p>SensAlert IR TRANSMITTER INIT MEMORY CARD ... Success</p>	<p>'INIT MEMORY CARD ...' – Memory card system Initializing. 'SUCCESS' or 'FAILURE' will show after a few seconds.</p>

## SensAlert IR Transmitter

S1		ID: XXX / YYY
	SENSOR	0-WAITING
	INIT	WAITING
S2		

S1	SENSOR	ID: XXX / YYY
	WARMUP	0-WAITING
	-ENT- TO	WAITING
S2	ABORT	

S1		ID: XXX / YYY
	SENSOR	0-WAITING
	UPLOAD	WAITING
S2		

'S1' or 'S2' alternates and identifies that the displayed data is for either Sensor 1 or Sensor 2.

'ID: XXX' refers to the user assigned ID for Sensor 1.

'ID: YYY' refers to the user assigned ID for Sensor 2.

'SENSOR WARMUP' – indicates that the given sensor (S1 or S2) is warming up.

'SENSOR UPLOAD' – Sensor is uploading its parameters to the SensAlert IR Transmitter.

## 9. NORMAL OPERATION

In the normal operating mode, the 4-20 mA signal levels correspond to the detected gas concentration. The transmitter continuously checks for and displays system faults or initiation of calibration and automatically changes to the appropriate mode.

The 4-20 mA output ports of the SensAlert IR are non-isolated current source(s), passed through from the attached sensor(s). Their output values are defined by the associated sensor manual(s) (4 – 20 mA normal gas levels, less than (<) 4 mA indicates a status condition such as warm-up, calibration, or a sensor fault).

### Normal Operation Screen



In normal operating mode actual gas concentration will be displayed on the left of the screen. The right side of the screen will display the ID #, Range, Gas Type and Status. The bottom line will scroll through the MC (memory card) status, Date, Time and, if a sensor has a warning code, will display 'WARN: xxx' where 'xxx' is a cell code #.

Example:

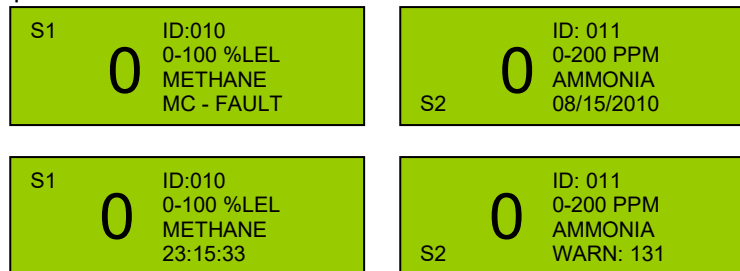

The normal display screen will toggle between sensor one and sensor two information at a rate of approximately once every two to three seconds. The alarm and fault LEDs indicate the alarm/fault status for the current sensor displayed at any given time as well. The operator may choose to advance the information displayed to the next sensor's information by selecting either the UP or DN switches. Doing so will immediately toggle the normal display screen information for the sensor not currently displayed (i.e., If display is currently showing sensor one (S1) information, then sensor two (S2) information will be immediately displayed, whereas if the display is currently showing sensor two (S2) information, then selecting UP or DN switch will cause sensor one (S1) information to immediately be displayed). If the transmitter is in single sensor mode, then the display will NOT change, and the S1 or S2 indicators will NOT show on the LCD display.

If the attached sensor(s) detect a fault or warning, it will be displayed on the screen in decimal. See sections 19 and UNIT STATUS FLASH CODES20 for more information on error and warning codes.

**Note: If the SensAlert IR Transmitter cannot communicate with a sensor, either on sensor 1 or sensor 2 it will indicate sensor fault on the one it cannot communicate with. Check the wiring and the +24VDC of the sensor if this occurs.**

## 10. SETUP – CONFIGURATION OPERATION

Once the SensAlert IR is powered up it may have to be configured to run correctly based on the system in which it is intended to be operated. For example, it will have to be set up based on whether it has one or two sensors attached, how the alarm relays are intended to operate and the network settings and ID will have to be set for the Modbus communication.

### 10.1. Required Sequence for Changes to Configuration

There is a very important order to setting Network IDs, sensor and network ID modes/roles and bus line settings. It should be done as follows:

1. Verify that the SensAlert IR Transmitter is offline (turn Modbus mode to 'OFF')
2. Change the Sensor Role to either Identical or Unique to unlock subsequent adjustments.
3. Set the relay control Latching, Delay and Logic (AND, OR, Sensor 1 or Sensor 2).
4. Assign the Sensor Mode – Identical, Unique, or Single
5. Set Alarm Thresholds and Activation Modes.
6. Set the Network ID mode – Unique or Identical.
7. Set the Network and Zone IDs.
8. Set the RS485 Modbus line settings.
9. Place the SensAlert IR Transmitter and its sensors 'online' by activating it on the RS485 Modbus network.

### 10.2. Date and Time

Entering this menu will allow the operator to set the date, time and day of the week of the SensAlert IR Transmitter real time clock.

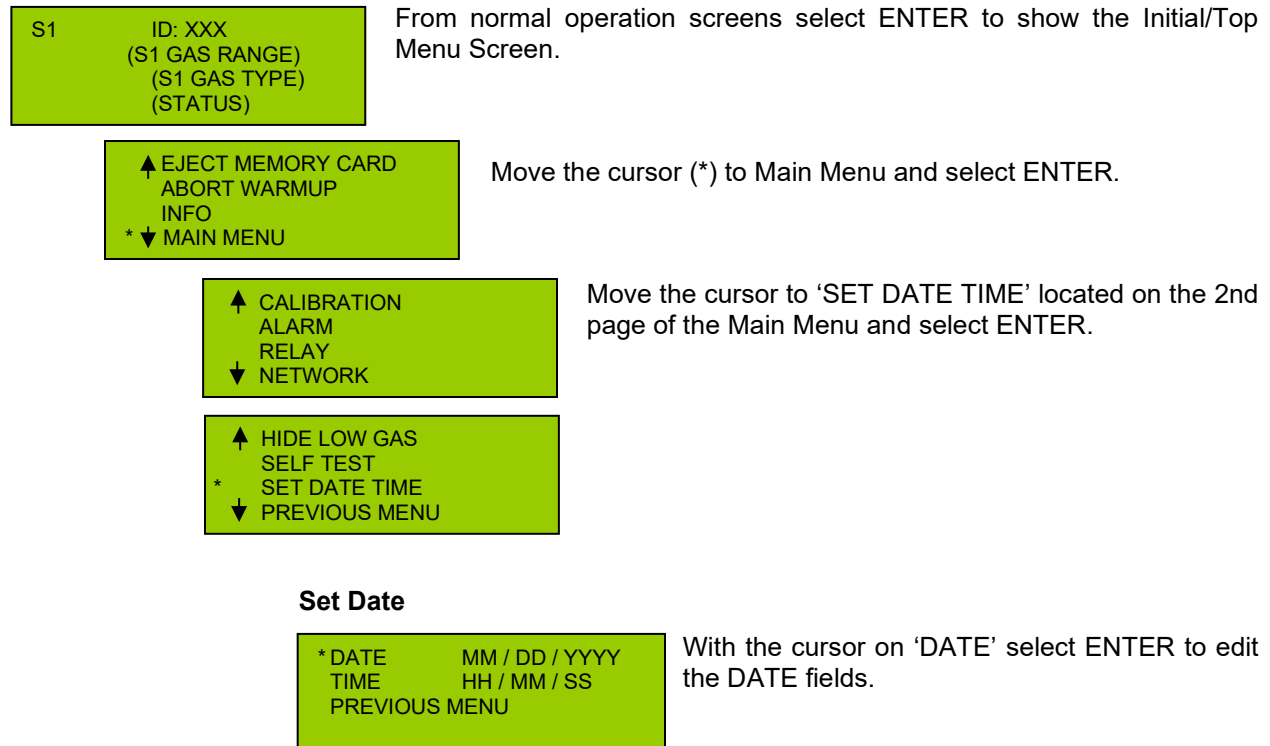

```
*DATE:  *MM / DD / YYYY
TIME:   HH / MM / SS
PREVIOUS MENU
```

Use the UP and DOWN switches to choose the month, day or year to edit and select ENTER

```
*DATE:  *MM / DD / YYYY *
TIME:   HH / MM / SS
PREVIOUS MENU
```

Use the UP and DOWN switches to set the value and select ENTER.  
(Edit **Month** is shown in figure.)

```
*DATE:  MM * DD / YYYY
TIME:   HH / MM / SS
PREVIOUS MENU
```

Use the UP and DOWN arrows to move between month, day, and year.  
**(Day)**

```
*DATE:  MM / DD * YYYY
TIME:   HH / MM / SS
PREVIOUS MENU
```

**(Year)**

```
*DATE:  MM / DD / YYYY *
TIME:   HH / MM / SS
PREVIOUS MENU
```

You must move cursor to the right of the year and select ENTER to exit changing the date and be able to move on to setting the time or moving to the previous menu.

**Set Time**

```
DATE    MM / DD / YYYY
*TIME   HH / MM / SS
PREVIOUS MENU
```

Select ENTER to edit the TIME field.

```
DATE:    MM / DD / YYYY
*TIME:  *HH / MM / SS
PREVIOUS MENU
```

Use the UP and DOWN switches to choose the hour, minutes, or seconds to edit and select ENTER.

```
DATE:    MM / DD / YYYY
*TIME:  *HH / MM / SS *
PREVIOUS MENU
```

Use the UP and DOWN switches to set the value and select ENTER (edit hour is shown in figure).

```
DATE:    MM / DD / YYYY
*TIME:  *HH / MM / SS
PREVIOUS MENU
```

Use the UP and DOWN arrows to move between hours, minutes, and seconds.

**(Hours)**

```
DATE:    MM / DD / YYYY
*TIME:  HH * MM / SS
PREVIOUS MENU
```

**(Minutes)**

```
DATE:    MM / DD / YYYY
*TIME:  HH / MM * SS
PREVIOUS MENU
```

**(Seconds)**

```
DATE:    MM / DD / YYYY
*TIME:  HH / MM / SS *
PREVIOUS MENU
```

You must move cursor to the right of the seconds and select ENTER to exit changing the hour and be able to move on to the previous menu.

SensAlert IR Transmitter

DATE: MM / DD / YYYY  
TIME: HH / MM / SS  
\* PREVIOUS MENU

ENTER on 'PREVIOUS MENU' to exit changing the date and time and return to the Main Menu.

\* SAVE CHANGES  
ABORT CHANGES

ENTER on 'SAVE CHANGES' to keep the new settings or 'ABORT CHANGES' to cancel them. Either choice will return to the Main Menu.

▲ HIDE LOW GAS  
SELF TEST  
SET DATE TIME  
\* ▼ PREVIOUS MENU

ENTER on 'PREVIOUS MENU' to return back to the Initial / Top Menu.

### 10.3. Relay Settings – Latching, Delay and Control Logic

The Relay Menu is found in the Main Menu.

S1 ID: XXX  
(S1 GAS RANGE)  
(S1 GAS TYPE)  
(STATUS)

From normal operation screens select ENTER to show the Initial/Top Menu Screen.

▲ EJECT MEMORY CARD  
ABORT WARMUP  
INFO  
\* ▼ MAIN MENU

Select ENTER on MAIN MENU.

#### Relay Menu (Selected from the Main Menu)

▲ CALIBRATION  
ALARM  
\* RELAY  
▼ NETWORK

Move the cursor to RELAY and select ENTER to open the relay menu.

#### Latching:

Each relay; Low, Mid, High and Fault; can be individually configured to latch when it is activated. Setting a relay to 'latch' will cause it to remain activated after the condition that activated the relay has cleared. This causes the user to acknowledge the activation to clear any alarms. See the end of this section on how to do this.

**NOTE:** As required by 60079-29-1 performance standard, the default LATCH setting for the HIGH alarm is LATCHING.

#### Delay:

Delay can also be applied to the activation (ON) or deactivation (OFF) of the individual relays. The delay can be up to 255 seconds for each setting. If a delay is set to the relay activation (ON DELAY) the alarm or fault associated with that relay will not be triggered until after the alarm condition has remained for the duration of the delay. Similarly, if a delay is applied to the deactivation (OFF DELAY) the alarm will remain engaged for the number of seconds beyond when the alarm condition has cleared. Use caution when applying ON DELAY to the activation of alarm relays as an unsafe atmosphere may be present for up to 255 seconds prior to any alarms being activated.

**Setting Relay Latching and Delay Conditions – set individually for each alarm/fault relay**

\* ↑ LOW  
MID  
HIGH  
↓ FAULT

Move the cursor to the desired alarm (LOW, MID, HIGH or FAULT) and select ENTER.

↑ LOGIC MODE  
↓ PREVIOUS MENU

\* ↑ LATCH 'NORMAL'  
ON DLY XXX  
OFF DLY XXX  
↓ ENERGIZED YES / NO

Within the LOW, MID, HIGH and FAULT pages the user can set:

- the relay latching style \*\*
- the on delay in seconds (0-255)
- the off delay in seconds (0-255)
- the energized state (NO = relay not energized until activated {resembles normally open contact action}, YES = relay energized until activated {resembles normally closed contact action})

**NOTE:** The fault relay is set to energized by default. This is so if the device loses power, the relay toggles and indicates to the unit's power has been lost. For this to work, the fault relay must be utilized by being wired to a light, horn, or some other indicator.

\*\* Latching Mode:

- Normal = relays do not latch.
- Latching = relays remain activated until forced reset.
- Audible = relays can be silenced by user (forced off).

\* ↓ PREVIOUS MENU

ENTER on 'PREVIOUS MENU' to return to the Relay Menu and choose to permanently save or abort the changes.

\* SAVE CHANGES  
ABORT CHANGES

ENTER on 'SAVE CHANGES' to retain new settings or 'ABORT CHANGES' to cancel them. Either choice will return to the Relay Menu.

**Logic:**

A key feature in the SensAlert IR Transmitter is the Sensor Role because only one set of relays is provided to service both attached sensors. Therefore, in determining the sensor mode, a decision regarding how the relays will be used must be considered and a decision concerning what relay mode is used must be made. Below is a list of possible relay modes:

- **Sensor One** – All alarm relays are determined exclusively from the alarm status of sensor one. The fault relay is engaged by either a sensor one fault condition or an SensAlert IR Transmitter fault condition. Alarm and fault states of sensor two will NOT cause any relays to be engaged. This relay mode is commonly used in conjunction with the Single Sensor Role and must be set PRIOR to setting the Single Sensor Role.
- **Sensor Two** – All alarm relays are controlled exclusively from the alarm status of sensor two. The fault relay is engaged by either a sensor one fault condition or an SensAlert IR Transmitter fault

condition. Alarm and fault states of sensor one will NOT cause any relays to be engaged. CAUTION: Sensor Two relay logic must not be used when the sensor mode is SINGLE.

- Logical AND** – All alarm relays are controlled by the logical AND condition of BOTH sensors one and two states. This means that for a low-alarm relay to be engaged, BOTH sensors must be reporting low relay alarm states (gas levels above the low alarm threshold). For a mid-alarm relay to be engaged, BOTH sensors must be reporting at least mid-relay alarm states. For a high-alarm relay to be engaged, BOTH sensors must be reporting high alarm states. This relay mode is best utilized in the Identical Sensor Role and should be set PRIOR to setting the Identical Sensor Role. The fault relay will engage if EITHER sensor is reporting a fault condition, or if the SensAlert IR Transmitter is in a fault state. CAUTION: AND or SENSOR TWO relay logic must not be used when the sensor mode is SINGLE.
- Logical OR** – All alarm relays are controlled by the logical OR condition of BOTH sensor one and sensor two states. This means that for a low-alarm relay to be engaged, EITHER sensor may be reporting a low relay alarm state. For a mid-alarm relay to be engaged, EITHER sensor may be reporting a mid-relay alarm state. For a high-alarm relay to be engaged, EITHER sensor may be reporting a high alarm state. This relay mode is commonly utilized in the Unique Sensor Role and should be set PRIOR to setting the Unique Sensor Role. The fault relay will engage if EITHER sensor is reporting a fault condition, or if the SensAlert IR Transmitter is in a fault state.

**Setting Relay Logic –**

↑ CALIBRATION  
ALARM  
\* RELAY  
↓ NETWORK

Move the cursor to RELAY and select ENTER to open the relay menu.

\* ↑ LOW  
MID  
HIGH  
↓ FAULT

Move the cursor to LOGIC MODE on the 2nd page of the RELAY menu and select ENTER.

\* ↑ LOGIC MODE  
↓ PREVIOUS MENU

\* MODE 'value'  
PREVIOUS MENU

Select ENTER with the cursor on MODE to choose the relays' logic. Use the UP and DOWN switches to choose the desired logic option:

- SENSOR ONE; relays respond to sensor one alarm states only.
- SENSOR TWO; relays respond to sensor two alarm states only.
- AND; relays will activate only when both sensor alarm states are at the same action level.
- OR; relays will activate when either sensor's alarm state is active.

MODE 'value'  
\* PREVIOUS MENU

ENTER on 'PREVIOUS MENU' to return to the Relay Menu and choose to permanently save or abort the changes.

\* SAVE CHANGES  
ABORT CHANGES

ENTER on 'SAVE CHANGES' to retain new settings or 'ABORT CHANGES' to cancel them. Either choice will return to the Relay Menu.

↑ LOGIC MODE  
\* ↓ PREVIOUS MENU

ENTER on 'PREVIOUS MENU' to return to the Main Menu.

### 10.3.1. Resetting Latched Relays

The Reset Relays Menu will allow the operator to reset latched relays. Latched relays will be indicated by a blue flashing Alarm LED.

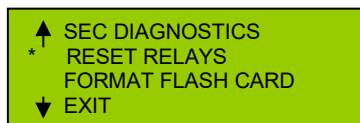
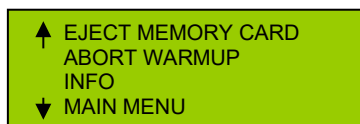

Select ENTER and any latched relays will be reset.  
The following will be briefly displayed (for about three seconds):

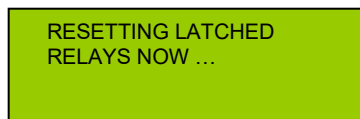

### 10.4. Sensor Mode – Single, Unique, or Identical

The SensAlert IR Dual Transmitter, unlike the SensAlert IR Single Transmitter, communicates with two sensors allowing for simultaneous gas measurement, display, transmission, and storage. This capability opens new opportunities for how sensors can be configured to work together in varying roles. The following is a brief look at the three configurations for the two sensor connectors:

- **Single Mode** – In this mode, the SensAlert IR Transmitter will only communicate / display / log information from a single sensor connected to the sensor 1 connector (see **Error! Reference source not found.**). Any device attached to the sensor 2 connector is ignored. A key feature in this mode is when no sensor is attached to the 2nd connector the SensAlert IR Transmitter does not signal a 'sensor missing' fault. In this mode the display mimics the behavior of the SensAlert IR Single Transmitter, yet retains the advanced features of the SensAlert IR Dual Transmitter. The Single Sensor Mode will default the Modbus Network ID mode to 'Single' and change all screens to disallow changing of sensor two parameters or displaying information for a second sensor.



**CAUTION:** Prior to setting the Sensor Mode to 'SINGLE' the relay logic should be configured to only respond to sensor one or logic OR.

- **Identical Mode** – In this mode, the SensAlert IR Transmitter will require two sensors to be attached to the sensor connector terminals. Both sensors must be of the same device type, measure identical gas types and identical gas value ranges. The distinguishing feature of this mode is if one sensor is not connected or if both sensors are not identical an error screen will be displayed, a UNIT FAULT will be issued, and the fault relay will be engaged.

This mode is commonly used for redundancy- such as two combustible sensors used to ensure that the actual combustible levels are truly at the same appropriate value before triggering the associated alarms. In this example the relay mode should be configured in the AND logical configuration for this method to work as described.

Relay logic modes for Sensor 1, Sensor 2 or logic OR are not prevented in the Identical sensor mode if the user would prefer to configure the relay mode as such. For example, if the user wants added security, one could choose logic OR, or if one sensor is faulty the relay mode may be set to the other sensor until repair/replacement can occur.

- **Unique Mode** – In this mode, the SensAlert IR Transmitter will communicate with two sensors attached to the sensor connector terminals. The two sensors can be of different sensor types, different gas types, different concentration ranges or could be identical but in different locations. Modbus IDs may be set to different values or to the same value. The relay mode may be set to any configuration. This sensor role allows the SensAlert IR Transmitter to consolidate two sensors to only one transmitter and allows logging of both sensor values to a single storage device. In this mode the SensAlert IR Transmitter will indicate a fault/warning if one sensor is not attached. It will not indicate a fault if the sensors are not identical.

The sensor mode in which the SensAlert IR Transmitter operates is chosen by the user and is a key decision that must be made before deploying or changing the sensing/monitoring plan. The choice will be determined by how many sensors are deployed, what gases are measured and how that data is captured.

**Change Sensor Mode**

S1 ID: XXX  
(S1 GAS RANGE)  
(S1 GAS TYPE)  
(STATUS)

Select ENTER to show the Initial/Top Menu Screen.

↑ EJECT MEMORY CARD  
ABORT WARMUP  
INFO  
\* ↓ MAIN MENU

Select ENTER on MAIN MENU.

↑ CALIBRATION  
ALARM  
RELAY  
\* ↓ NETWORK

Scroll down to NETWORK and select ENTER.

\* NETWORK ID MENU  
MODBUS SETTINGS  
PREVIOUS MENU

Scroll down and select ENTER on MODBUS SETTINGS to bring up the Modbus Settings Menu.

↑ ONLINE YES / NO  
\* SENSORS (MODE) \*  
NET ID (MODE)  
↓ 485 BUS MENU

Scroll down and select ENTER on SENSORS. Use the UP/DN switches to change the value to one of three possible modes:

- IDENT – where two sensors have the same gas, range and type and are used in a redundant mode,
- UNIQUE – where two sensors have completely different gas, range, or types,
- SINGLE – where only ONE sensor is attached to the sensor one plug.



**CAUTION:** Only one edit is retained when leaving this menu. When making changes to the 'MODBUS SETTINGS' menu, exit to the 'SAVE CHANGES' screen for each field being changed.

\* ↓ PREVIOUS MENU

Scroll down to bring up the next page of the Modbus Settings Menu. Select ENTER on PREVIOUS MENU to return the screen to the Network Menu.

\* NETWORK ID MENU  
MODBUS SETTINGS  
PREVIOUS MENU

Scroll down to PREVIOUS MENU and select ENTER to return the screen back to the Main Menu.

\* SAVE CHANGES  
ABORT CHANGES

Select ENTER on SAVE CHANGES to return the screen back to the Main Menu Screen.

SensAlert IR Transmitter

▲ CALIBRATION  
ALARM  
RELAY  
\* ▼ NETWORK

Scroll down to Page 2 of the Main Menu Screen.

▲ HIDE LOW GAS  
SELF TEST  
SET DATE TIME  
\* ▼ PREVIOUS MENU

Scroll down to and select ENTER on PREVIOUS MENU to return the screen to the Initial/Top Menu Screen.

▲ EJECT MEMORY CARD  
ABORT WARMUP  
INFO  
\* ▼ MAIN MENU

Scroll down to bring up Page 2 of the Initial/Top Menu Screen.

▲ SEC DIAGNOSTICS  
RESET RELAYS  
FORMAT FLASH CARD  
\* ▼ EXIT

Scroll down to and select ENTER on EXIT to return the screen to the Normal Operating Display.

## 10.5. Alarm Settings – Threshold Values and Active Mode

In the 'ALARM' menu the user can set the thresholds for the Low, Mid and High alarms for both sensors. The default values for these settings are as follows:

Alarm	Threshold
Low	20% of Full Scale
Mid	40% of Full Scale
High	60% of Full Scale

The 'Active Mode' of each alarm set point can also be changed in this menu. An Active High setting will trigger the alarm when the gas concentration is rising and crosses the threshold set point. An Active Low setting will trigger the alarm when the gas concentration is falling and crosses the threshold set point. The user can also change the "MUTE ON WARN" setting. This setting determines how the transmitter acts when the attached sensor goes into a warning. The default for this setting is "NO" meaning that if the unit goes into a warning but still senses gas, the transmitter relays will activate (LEDs will also change) when an alarm threshold has been met. Turning the setting "YES" will keep the transmitter relays from activating and the LEDs from changing color when the unit is in a warning.

### Alarm Menu (Selected from the Main Menu)

```

↑ CALIBRATION
* ALARM
  RELAY
↓ NETWORK
    
```

Move the cursor to ALARM and select ENTER to open the alarm menu.

```

* ↑ FOR SENSOR: ONE / TWO
  LOW
  MID
  ↓ HIGH
    
```

ENTER on 'FOR SENSOR' 'ONE/TWO' to choose which sensor to perform alarm configuration operations.

DOWN switch to select sensor one  
Up switch to select sensor two

```

↑ FOR SENSOR: ONE / TWO
* LOW
  MID
  ↓ HIGH
    
```

Move the cursor to the alarm to set (LOW, MID or HIGH) and select ENTER.

```

* THRESHOLD 'value'
  ACTIVE MODE HIGH/LOW
  PREVIOUS MENU
    
```

To set the alarm set-point move the cursor to THRESHOLD and select ENTER.

```

* THRESHOLD 'value' *
  ACTIVE MODE HIGH/LOW
  PREVIOUS MENU
    
```

Using the UP and DOWN switches set the desired value then select ENTER.

```

THRESHOLD 'value'
* ACTIVE MODE HIGH/LOW*
  PREVIOUS MENU
    
```

Selecting ACTIVE MODE will allow the operator to change the operation of the alarm activation operation from Active HIGH to Active LOW. Once the correct operation is selected select ENTER.

- HIGH activates the alarm on a rising gas level.
- LOW activates the alarm when the gas level falls below the alarm set point.

```

THRESHOLD 'value'
  ACTIVE MODE HIGH/LOW
* PREVIOUS MENU
    
```

ENTER on 'PREVIOUS MENU' to return to the Alarm Menu and choose to save or abort the changes.

\* SAVE CHANGES  
ABORT CHANGES

ENTER on 'SAVE CHANGES' to retain the new settings or 'ABORT CHANGES' to discard them.

↑ FOR SENSOR: ONE / TWO  
\* LOW  
MID  
↓ HIGH

Move cursor down to show next alarm sub menu.

\* ↓ MUTE ON WARN YES/NO  
PREVIOUS MENU

ENTER on 'MUTE ON WARN' to change how the transmitter acts when a sensor goes into a warning. Using up or down the value can be changed from YES to NO.

↓ MUTE ON WARN YES/NO  
\* PREVIOUS MENU

ENTER on 'PREVIOUS MENU' to return to the MAIN MENU

### 10.6. Network ID (Sensor / Display Network Identities)

The SensAlert IR Transmitter may be addressed on Modbus at a specific network ID, as any other Modbus compliant device does. However, it may also be accessed using two network device IDs, one for each sensor if that is how it is configured. Likewise, Modbus compliant Master devices may choose to communicate with the SensAlert IR Transmitter using a single network ID.

The SensAlert IR Transmitter Modbus Network ID Modes are:

- **Unique Mode** – This mode can be used for any Modbus Master. In this mode, Modbus Network IDs can be assigned to both sensors of any valid value, and do not have to be sequential.
- **Single Mode** – This mode can be used for any Modbus Master. In this mode, only one Modbus Network ID is assigned to the SensAlert IR Transmitter and all sensor information for all sensors attached is accessible.

#### Change Network ID Mode

↑ EJECT MEMORY CARD  
ABORT WARMUP  
INFO  
\* ↓ MAIN MENU

From the Initial/Top menu screen, move the cursor down to MAIN MENU and select ENTER.

↑ CALIBRATION  
ALARM  
RELAY  
\* ↓ NETWORK

Move the cursor down to the NETWORK Menu and select ENTER.

\* NETWORK ID MENU  
MODBUS SETTINGS  
PREVIOUS MENU

Select ENTER on MODBUS SETTINGS to bring up the Modbus Settings Menu Page 1 Screen

↑ ONLINE YES / NO  
SENSORS UNIQUE  
\* NET ID UNIQUE \*  
↓ 485 BUS MENU

The operator may change the Modbus Network ID mode by moving the cursor to NET ID selecting ENTER and using the UP/DN arrows to change the value to one of two modes:

- **UNIQUE** – where two sensors have different Modbus network ID and zone values and can be addressed independently on Modbus network,

- SINGLE – where one or both sensors share a single Modbus network ID and zone ID and either sensor is accessed by this network ID.



CAUTION: Only one edit is retained when leaving this menu. When making changes to the 'MODBUS SETTINGS' menu exit to the 'SAVE CHANGES' screen for each field being changed.

↑ ONLINE NO  
SENSORS IDENT  
\* NET ID SINGLE  
↓ 485 BUS MENU

Scroll down to the 2nd page of the Modbus Settings Menu.

\* ↓ PREVIOUS MENU

Select ENTER on PREVIOUS MENU to return the screen to the Network Menu.

NETWORK ID MENU  
MODBUS SETTINGS  
\* PREVIOUS MENU

Scroll down to and select ENTER on PREVIOUS MENU to return the screen back to the Main Menu Screen.

\* SAVE CHANGES  
ABORT CHANGES

Select ENTER on SAVE CHANGES to return the screen back to the Main Menu Screen.

↑ CALIBRATION  
ALARM  
RELAY  
\* ↓ NETWORK

Scroll down to bring up Page 2 of the Main Menu Screen.

↑ HIDE LOW GAS  
SELF TEST  
SET DATE TIME  
\* ↓ PREVIOUS MENU

Scroll down to PREVIOUS MENU and select ENTER to return the screen to the Initial/Top Menu Screen.

↑ EJECT MEMORY CARD  
ABORT WARMUP  
INFO  
\* ↓ MAIN MENU

Ready for next operation.

**Set the Network and Zone IDs**

↑ EJECT MEMORY CARD  
ABORT WARMUP  
INFO  
\* ↓ MAIN MENU

From the Initial/Top menu screen, cursor down to the Main Menu and select ENTER.

↑ CALIBRATION  
ALARM  
RELAY  
\* ↓ NETWORK

Move the cursor down to the NETWORK menu and select ENTER.

\* NETWORK ID MENU  
MODBUS SETTINGS  
PREVIOUS MENU

Select ENTER on NETWORK ID MENU.

\* FOR SENSOR: ONE/TWO \*  
ID XXX  
ZONE YYY  
PREVIOUS MENU

If the ID mode (see Modbus settings menu) is not set to 'Single' and Sensor Role (see Modbus settings menu) is not

set to 'Single', then you may change the ID and Zone number for either sensor one or two by choosing the sensor number. Select ENTER on 'FOR SENSOR' item, and use the UP/DN arrows to change between ONE and TWO. Otherwise, if ID mode or Sensor Role is set to 'Single' all changes will be made with SENSOR ONE displayed.

```

FOR SENSOR: ONE/TWO
* ID           XXX *
  ZONE        YYY
  PREVIOUS MENU
    
```

To set the ID of each sensor move the cursor to ID and select ENTER. The IDs of the sensors may be set in the range 1-254, however they cannot be set to the same value.

Note: Be sure to assign the sensor an ID number not shared by any other sensors in the HMI's network.

```

FOR SENSOR: ONE/TWO
ID           XXX
* ZONE        YYY *
  PREVIOUS MENU
    
```

To set the Zone of each sensor move the cursor to ZONE and select ENTER. The ZONE can be set in the range 1-254.

```

FOR SENSOR: ONE
ID           13
  ZONE        3
* PREVIOUS MENU
    
```

Scroll down and select ENTER on PREVIOUS MENU to return to the Network Menu Screen.

```

NETWORK ID MENU
MODBUS SETTINGS
* PREVIOUS MENU
    
```

Scroll down to and select ENTER on PREVIOUS MENU to return to the Main Menu.

```

* SAVE CHANGES
  ABORT CHANGES
    
```

ENTER on 'SAVE CHANGES' to return to the Main Menu.

```

↑ CALIBRATION
  ALARM
  RELAY
* ↓ NETWORK
    
```

Scroll down to Main Menu page 2.

```

↑ HIDE LOW GAS
  SELF TEST
  SET DATE TIME
* ↓ PREVIOUS MENU
    
```

Scroll down to PREVIOUS MENU and select ENTER to return the screen to the Initial/Top Menu.

```

↑ EJECT MEMORY CARD
  ABORT WARMUP
  INFO
* ↓ MAIN MENU
    
```

Ready for next operation.

## 10.7. Modbus Settings

The SensAlert IR Transmitter can speak to various devices that communicate using standard 16-bit Modbus. (For more details, see the SensAlert IR Transmitter 16-bit Modbus Technical Sheet) Based on the Modbus register address and function code combinations provided in queries to the Transmitter by a Modbus Master, it can distinguish which HMI protocol is appropriate. The SensAlert IR Transmitter communicates over RS485 as a Modbus RTU Slave (compatible with Modicon Modbus Specification PI-MBUS-300 Rev. J) and does not perform any bus-management functions.

### Configuring SensAlert IR Transmitter RS485 Bus Parameters

Since the SensAlert IR Transmitter implements Modbus RTU over RS485, bus communication parameters can be changed to accommodate various line configurations for other Modbus compliant Masters (compatible with Modicon Modbus Specification PI-MBUS-300 Rev. J).

- **Baud Rate:** 9600
- **Parity:** None
- **Stop Bits:** 2
- **Data Bits:** 8

A different Modbus compliant Master, such as a Modbus Ethernet Gateway, may choose to use a different configuration. The Most common alternative configuration is as follows (485 Bus Settings Menu Item ALTERNATE):

- **Baud Rate:** 9600
- **Parity:** None
- **Stop Bits:** 1
- **Data Bits:** 8

The operator may choose to completely configure the communication configuration by setting custom settings (485 Bus Settings Menu Item CUSTOM):

- **Baud Rates:** 1200, 2400, 4800, 9600, 19200, 38400
- **Parity:** None, Odd, or Even
- **Stop Bits:** 1 or 2
- **Data Bits:** 8 or 9

Though the parameters are customizable, the total frame of bits cannot exceed ten (not including the start bit), hence 8 data bits with 2 stop bits will be valid, but parity cannot be used. Likewise, 8 data bits with parity is valid with only 1 stop bit. Nine data bits can only be valid with one stop bit and no parity. Though the operator may create a configuration greater than ten total bits, the transceivers by default will adapt a replacement frame that remains ten bits in length and will resemble the most common frame format.

### Activating Modbus Communication - Put the SensAlert IR Transmitter Online or Offline

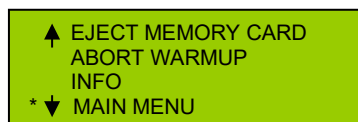

Scroll down to MAIN MENU and select ENTER.

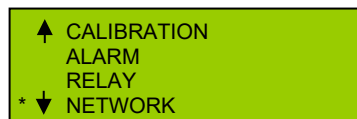

Move the cursor down to the NETWORK menu and select ENTER.

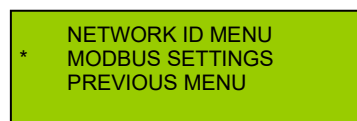

Select ENTER on MODBUS SETTINGS to bring up the Modbus Settings Menu.

SensAlert IR Transmitter

\* ↑ ONLINE YES / NO \*  
 SENSORS UNIQUE  
 NET ID UNIQUE  
 ↓ 485 BUS MENU

The operator can place the unit actively on RS485 bus, or take it off by moving the cursor to ONLINE, selecting ENTER and using the UP/DN arrows to change the value between YES and NO.

\* ↑ ONLINE YES  
 SENSORS IDENT  
 NET ID SINGLE  
 ↓ 485 BUS MENU

Scroll down to the Modbus Settings Menu Page 2.

\* ↓ PREVIOUS MENU

Select ENTER on PREVIOUS MENU to exit the Modbus Settings Menu and return to the Network Settings Menu Screen.

NETWORK ID MENU  
 MODBUS SETTINGS  
 \* PREVIOUS MENU

Scroll down to and select ENTER on PREVIOUS MENU to return to the Main Menu Screen.

\* SAVE CHANGES  
 ABORT CHANGES

Select ENTER on SAVE CHANGES. The screen will return to the Main Menu.

↑ CALIBRATION  
 ALARM  
 RELAY  
 \* ↓ NETWORK

Scroll down to Main Menu Page 2.

↑ HIDE LOW GAS  
 SELF TEST  
 SET DATE TIME  
 \* ↓ PREVIOUS MENU

Scroll down to and select ENTER on PREVIOUS MENU to return to the Initial/Top Menu Screen.

**Set RS485 Modbus Line Settings (Data Bits, Stop bits, Parity and BAUD)**

↑ EJECT MEMORY CARD  
 ABORT WARMUP  
 INFO  
 \* ↓ MAIN MENU

Scroll down to MAIN MENU and select ENTER.

↑ CALIBRATION  
 ALARM  
 RELAY  
 \* ↓ NETWORK

Move the cursor down to the NETWORK menu and select ENTER.

\* NETWORK ID MENU  
 MODBUS SETTINGS  
 PREVIOUS MENU

Select ENTER on MODBUS SETTINGS to bring up the Modbus Settings Menu.

**RS485 Bus Settings Menu**

↑ ONLINE YES / NO  
 SENSORS UNIQUE  
 NET ID UNIQUE  
 \* ↓ 485 BUS MENU

The operator may change the Modbus RS485 settings by selecting ENTER on 485 BUS MENU. The following sub-menu will show:

**485 Bus Default Settings**

\* COMM- DEFAULT  
 COMM- ALTERNATE  
 COMM- CUSTOM  
 PREVIOUS MENU

The operator can set the 485 bus to communicate using DEFAULT line values by moving the cursor to COMM-DEFAULT and selecting ENTER. The default values are 9600 baud, 8 data bits, no parity and 2 stop bits. The following display is shown:

DEFAULT COMM PARAMS  
 F BITS: 8 S BITS: 2  
 PAR: N RATE: 9600  
 -ENT- TO CONTINUE

This is just an informational box to indicate what the settings are. The operator may select ENTER to return to the 485 bus menu.

**485 Bus Alternate Settings**

COMM- DEFAULT  
 \* COMM- ALTERNATE  
 COMM- CUSTOM  
 PREVIOUS MENU

The operator can set the 485 bus to communicate using ALTERNATE line values by moving the cursor to COMM-ALTERNATE and selecting ENTER. The alternate values are 9600 baud, 8 data bits, no parity and 1 stop bit. The following display is shown:

ALT. COMM PARAMS  
 F BITS: 8 S BITS: 1  
 PAR: N RATE: 9600  
 -ENT- TO CONTINUE

This is just an informational box to indicate what the settings are. The operator may select ENTER to return to the 485 bus menu.

### 485 Bus Custom Settings Menu

```

COMM- DEFAULT
COMM- ALTERNATE
* COMM- CUSTOM
PREVIOUS MENU
    
```

The operator can set the 485 bus to custom communication settings by moving the cursor to COMM- CUSTOM and selecting ENTER. The following screen will show:

```

* ↑ DATA BITS EIGHT *
  STOP BITS TWO
  PARITY NONE
  ↓ BAUD RATE 9600
    
```

The operator may change the data bits by moving the cursor to DATA BITS and select ENTER, then using the UP/DN arrows to change the value to either 'EIGHT' or 'NINE'.

```

↑ DATA BITS EIGHT
* STOP BITS TWO *
  PARITY NONE
  ↓ BAUD RATE 9600
    
```

The operator may change the stop bits by moving the cursor to STOP BITS and select ENTER, then using the UP/DN arrows to change the value from either 'ONE' or 'TWO'.

```

↑ DATA BITS EIGHT
  STOP BITS TWO
* PARITY NONE *
  ↓ BAUD RATE 9600
    
```

The operator may change the parity checking by moving the cursor to PARITY and select ENTER, then using the UP/DN arrows to change the value from 'NONE', 'ODD' or "EVEN".

```

↑ DATA BITS EIGHT
  STOP BITS TWO
  PARITY NONE
* ↓ BAUD RATE 9600 *
    
```

The operator may change the baud rate by moving the cursor to BAUD RATE and select ENTER, then using the UP/DN arrows to change the value to one of {1200, 2400, 4800, 9600, 19200 and 38400}.

```

* ↓ PREVIOUS MENU
    
```

Return to the 485 bus menu and save the changes by moving the cursor to the next screen and select ENTER.

```

COMM- DEFAULT
COMM- ALTERNATE
COMM- CUSTOM
* PREVIOUS MENU
    
```

Scroll down to PREVIOUS MENU and select ENTER to return to the Modbus Settings Menu Screen.

```

NETWORK ID MENU
* MODBUS SETTINGS
  PREVIOUS MENU
    
```

Scroll down to PREVIOUS MENU and select ENTER to return to the Main Menu Screen.

```

* SAVE CHANGES
  ABORT CHANGES
    
```

Select ENTER on SAVE CHANGES to return to the Main Menu Screen.

## 11. SENSOR CALIBRATION

If the user is going to perform a span calibration, a zero calibration is **REQUIRED** to be performed first.

Calibration Menu (Selected from the Main Menu)

```
* ↑ CALIBRATION
  ALARM
  ↓ RELAY
  NETWORK
```

ENTER to select the calibration menu.

```
* ↑ SELECT SENSOR ONE/TWO
  ZERO
  SPAN
  ↓ CAL. VAL 2.50
```

ENTER on 'SELECT SENSOR' 'ONE/TWO' to choose which sensor to perform calibration operations.

DOWN switch to select sensor one

Up switch to select sensor two

### 11.1. Zero Cal

```
↑ SELECT SENSOR ONE/TWO
* ZERO
  SPAN
  ↓ CAL. VAL 2.50
```

To Zero the sensor, move the cursor to ZERO and select enter.

```
ZERO CAL 'present gas value'
SENSOR ONE / TWO
↓ PREV. -ENT- START
```

Apply clean air (N2 for an oxygen sensor) and wait for the 'present gas value' to indicate a stable value.

Select ENTER.

The following screens will be displayed.

```
ZERO CAL
SENSOR ONE
1. WAIT FOR START
-ENT- TO ABORT
```

```
ZERO CAL
SENSOR ONE
1. IN PROGRESS
-ENT- TO ABORT
```

```
ZERO CAL
SENSOR ONE
1. COMPLETE
DONE, STOPPING...
```

```
SETTING CAL. DATE
SENSOR ONE
1. WAIT FOR START
-ENT- TO ABORT
```

```
SETTING CAL. DATE
1. IN PROGRESS
```

```
ZERO CAL
SENSOR ONE
1. RECORDING CAL DATA
```

```
ZERO CAL.
1. COMPLETE
DONE, STOPPING...
```

## SensAlert IR Transmitter

▲ SELECT SENSOR ONE/TWO  
\* ZERO  
SPAN  
▼ CAL. VAL 2.50

Once complete the SensAlert IR Transmitter will return to the calibration menu. The sensor has been successfully zeroed if no faults are indicated.

## 11.2. Span Cal (and Calibration Value)

```

↑ SELECT SENSOR ONE/TWO
  ZERO
  SPAN
* ↓ CAL. VAL  2.50
    
```

Arrow down to CAL. VAL to verify the span gas calibration value matches the concentration of the span calibration gas on hand. If not, select Enter and the following screen will appear.

```

↑ SELECT SENSOR ONE/TWO
  ZERO
  SPAN
* ↓ CAL. VAL  2.50  *
    
```

Using the Up and Down arrows will allow the operator to change the calibration gas value of the sensor to match the calibration gas used to span the sensor. Once the correct value is displayed select ENTER.

```

* SAVE CHANGES
  ABORT CHANGES
    
```

ENTER to select 'SAVE CHANGES' to send the calibration gas value to the sensor, or 'ABORT CHANGES' to return to the previous screen.

The Following screens are displayed:

```

SET CALIBRATION VAL.
1. WAIT FOR START
    
```

```

SET CALIBRATION VAL.
1. IN PROGRESS
    
```

```

SET CALIBRATION VAL.
1. COMPLETE

DONE, STOPPING...
    
```

```

↑ SELECT SENSOR ONE/TWO
  ZERO
*  SPAN
↓  CAL. VAL  2.50
    
```

To Span calibrate the sensor, move the cursor to SPAN and select ENTER.

```

SPAN CAL 'present gas value'
SENSOR    ONE / TWO
↓ PREV.  -ENT-  START
    
```

Apply calibration gas and wait for the 'present gas value' to indicate a stable value. Select ENTER.

The following screens will be displayed.

```

SPAN CAL
SENSOR ONE
1. WAIT FOR START
  -ENT- TO ABORT
    
```

```

SPAN CAL
SENSOR ONE
1. IN PROGRESS
  -ENT- TO ABORT
    
```

```

SPAN CAL
SENSOR ONE
1. COMPLETE
DONE, STOPPING...
    
```

SETTING CAL. DATE  
 SENSOR ONE  
 1. WAIT FOR START  
 -ENT- TO ABORT

SETTING CAL. DATE  
 1. IN PROGRESS

SPAN CAL  
 SENSOR ONE  
 1. RECORDING CAL DATA

SPAN CAL.  
 1. COMPLETE  
 DONE, STOPPING...

PURGE GAS 'present gas val'  
 SENSOR ONE / TWO  
 -ENT- TO ABORT

After Span calibration has completed the operator will be prompted to purge the cal gas. The operator can then apply clean air to the sensor

▲ SELECT SENSOR ONE/TWO  
 ZERO  
 \* SPAN  
 ▼ CAL. VAL 2.50

Once the measured gas value is less than 25% of the LOW alarm set point the SensAlert IR Transmitter will return to the calibration menu. The sensor has been successfully calibrated if no faults are indicated.

▲  
 \* FACTORY RESTORE  
 ▼ PREVIOUS MENU

Move cursor down to display final calibration menu option to return to PREVIOUS MENU

ENTER to return to the MAIN MENU

\* ▲ CALIBRATION  
 ALARM  
 RELAY  
 ▼ NETWORK

### 11.3. Factory Restore

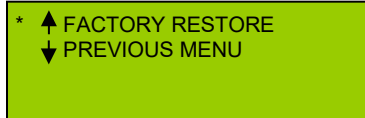

The FACTORY RESTORE menu will allow the user to restore the sensor to factory defaults. This is convenient if a user mis-calibrates a sensor and wants to revert to its original calibration. Refer to the table below for a list of Sensidyne products and software revisions that contain this function.

Product	Software Revision
SensAlert IR Sensor	27 or newer
SensAlert IR Tall Sensor	21 or newer

Each sensor can be factory restored individually by selecting either sensor one or sensor two as when doing a zero/span calibration.

Selecting Enter on FACTORY RESTORE will display the following:

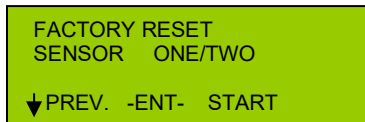

Using arrow down will bring the user back to the previous page.

Selecting Enter will issue the factory restore command to sensor one or sensor two depend on which had been selected. The display will briefly show the following:

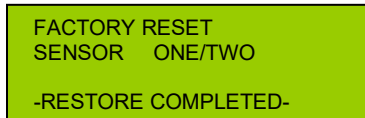

After this the sensor that was restored will go through the warmup sequence again

## 12. DIAGNOSTIC FUNCTIONS

The Diagnostics Menu will allow the operator to command the SensAlert IR Transmitter to reboot, toggle the LEDs (typically 'Locator Mode' with alternating flashing red/green alarm/fault lights), and toggle the individual relays on and off to verify operation.

```

↑ EJECT MEMORY CARD
  ABORT WARMUP
  INFO
↓ MAIN MENU
    
```

```

↑ * SEC DIAGNOSTICS
  RESET RELAYS
  FORMAT FLASH CARD
↓ EXIT
    
```

### Reboot System

```

* REBOOT SYSTEM
  TOGGLE LEDS ON/OFF
  TOGGLE RELAYS
  PREVIOUS MENU
    
```

By selecting ENTER with the cursor on REBOOT SYSTEM the operator will command the SensAlert IR to reboot. This action results in the SensAlert IR Transmitter being rebooted and normal power up initialization will occur.

### Toggle Relays

```

REBOOT SYSTEM
TOGGLE LEDS
* TOGGLE RELAYS
  PREVIOUS MENU
    
```

Selecting ENTER will display the toggle relays menu.

```

* ↑ LOW           ON/OFF
  MID           ON/OFF
  HIGH          ON/OFF
↓ FAULT        ON/OFF
    
```

The user can select the desired relay to test and toggle its activation ON or OFF using the UP and DOWN switches.

```

* ↓ PREVIOUS MENU
    
```

ENTER on 'PREVIOUS MENU' to return to the Diagnostics Menu.

```

S1          ID: 001
10.4       0-100 %LEL
           METHANE
           SELF TEST
    
```

### 13. SELF-TEST MENU

The self-test function will make the sensor generate a 4-20mA current into the SensAlert IR Transmitter from 4mA to 20mA (0-fullscale). In the self-test mode, the SensAlert IR Transmitter outputs are fully functional. The SensAlert IR Transmitter will display the rising gas level, the 4-20 mA output will increase to 20 mA, the relays will activate and the RS485 information will be transmitted to the control system.

```

↑ HIDE LOW GAS
* SELF TEST
  SET DATE TIME
↓ PREVIOUS MENU
  
```

Move the cursor to SELF TEST and select ENTER to open the self-test menu.

```

* ON SENSOR: ONE/TWO/BOTH
  CANCEL REQUEST
  ABORT TEST
  START SELF TEST
  
```

The self-test can be run on sensor 1, sensor 2 or both sensors simultaneously.

During the self-test the display will be normal with the exception that the bottom line will indicate that the self-test is being run.

Example:  
Self-test running on both sensors.  
SELF TEST will display

```

S1          ID: 001
10.4       0-100  %LEL
           METHANE
           SELF TEST
  
```

In the status line for the given sensor under test, if only sensor one is in self-test, then the SELF TEST will only appear for SENSOR one. Otherwise, if it is sensor two, then the status line will only appear for SENSOR two. If both sensors are in self-test in the example above, then as the display toggles between sensor one and two, the status line will remain indicating SELF TEST for both sensor display updates.

Once the unit reaches full scale the SensAlert IR Transmitter automatically returns to normal, and the SELF TEST status will be removed from the display for that sensor.

## 14. INFO MENU CONTENTS

Using the UP and DOWN magnetic switches move the cursor to the desired field.

```

↑ EJECT MEMORY CARD
  ABORT WARMUP
*  INFO
↓  MAIN MENU
    
```

Entering the INFO menu will display the initial Info Menu

```

* UNIT INFO
  SENSOR INFO
  PREVIOUS MENU
    
```

Selecting Enter at 'UNIT INFO' displays the information for the SensAlert IR Transmitter.

```

SENSALERT IR TRANSMITTER
VER: X.YY.RRRR
UNIT SN: 000035641
-ENT- TO EXIT
    
```

'VER' is the SensAlert IR Transmitter software version number.  
'UNIT SN' is the SensAlert IR Transmitter serial number.

```

UNIT INFO
* SENSOR INFO
  PREVIOUS MENU
    
```

Selecting Enter at SENSOR INFO displays the information for both sensors.

```

SENSOR INFO DISPLAY
IN: 003 SECONDS
  PRESS
-ENT- TO EXIT
    
```

'003' counts down to '000' seconds

	-S1 DDD-	-S2 EEE
TYP:	XXX	YYY
FW:	XX.X	YY.Y
SN:	XXXXX	YYYYY

'DDD' – Device ID for sensor 1  
'EEE' – Device ID for sensor 2  
TYP: Sensor type  
(32 is SensAlert IR Sensor)  
FW: Version of sensor software.  
SN: Sensor serial number.

To exit the 'info' screen select 'ENTER'. The info screen will timeout after ~30s and return to the previous screen

```

UNIT INFO
  SENSOR INFO
* PREVIOUS MENU
    
```

Select PREVIOUS MENU to go back to the initial menu screen.

## 15. HIDE LOW GAS

The Hide function allows the operator to not display the gas reading (will always show 0) until the Low Alarm threshold is exceeded. All outputs will function as normal when the Hide mode selected is YES.

```
* ↑ HIDE LOW GAS
  SELF TEST
  SET DATE TIME
  ↓ PREVIOUS MENU
```

By selecting ENTER at HIDE LOW GAS, the operator can choose to hide or not hide gas levels below the low threshold. The following screen will appear:

```
  HIDE LOW GAS:
  *   YES / NO   *
  PREVIOUS MENU
```

By selecting ENTER on YES/NO the user may change the value using the UP/DN arrows. After selecting ENTER after setting the value, the operator may move the cursor to PREVIOUS MENU and select ENTER to go back to the main menu after choosing to SAVE or ABORT the changes.

```
*   SAVE CHANGES
  ABORT CHANGES
```

## 16. DATA LOGGING (OPTIONAL)

The SensAlert IR Transmitter provides event data logging to a flash card. The type of card used is MMC (MultiMedia Card). This flash card can be read by any personal computer that can read a FAT16 format file system, like cards from digital cameras and other portable devices. It should NEVER be formatted by a personal computer, rather be formatted by the SensAlert IR Transmitter itself under the Initial/Top Menu item "Format Flash Card". Data can be read directly from the flash card or copied to a personal computer. The file is a text file containing comma separated data values, one event per line. The text file will be the only file on the flash card, and currently will NOT be allowed to grow beyond 16MB (this is considered the memory card "full now" state). After the data is archived from the flash card, it can be re-formatted to start storage over. A flash card will typically not become full for many years.

### As The Memory Card Fills Up

When a flash card crosses 80% full (approximately 12 MB), the memory card status will change from "MC-OK" to "MC-FULL", warning the user to copy the contents off to a permanent storage location and reformat the card to start storage over. The SensAlert IR will continue to log data to the flash card until it reaches 100% full. At that time, the status will change to "MC-FULLNOW" indicating that there is no more room to store data. At this point data storage has STOPPED and events may be lost that would otherwise be stored. If the card is removed and reinserted, the SensAlert IR may eventually display the status as "MC-FAULT", indicating a memory card fault. The card MUST be formatted at this point.

### How Long It May Take to Fill a Memory Card

The shortest period to fill a memory flash data card is approximately 200 – 300 hours. To accomplish this, gas levels must be constantly changing beyond 5% of sensor range and alarm events and other related events must be persistently changing at a highly sustained rate. It is unlikely that this could ever happen under normal circumstances, since alarms would be sounding, and intervention would be absolutely necessary. If sensor(s) are properly calibrated, and normal maintenance is performed, the memory card will probably not fill up for ten years or more. Since the operating environment determines the amount of data and frequency for storage, the time it takes to fill a data card will differ for each installation.

### Flash Card Removal and Formatting

Removing a data flash card should not occur without selecting the first Top Menu Item "Eject Flash Card". This prepares the flash card for removal by writing any data cached in memory out to the file system and ensures the file system on the data flash card is not corrupted. Formatting a data flash card allows the card to start over and re-capture space. Caution should be exercised to ensure that any data needed is archived first since this process will erase all data. The file system will be re-started and prepared as if it was from the factory. Just select the Menu Item on the second page of the Top Menu "Format Flash Card" to begin the process.

### Data Log File Contents

Events such as a 5% gas level change, alarm state change, sensor warm-up, calibration, system power on, sensor fault or parameter changes are logged and stored. Data from normal operation is NOT recorded when gas levels do not change beyond a 5% band. Here is the data log format:

**LOG FILE EVENT ENTRY FORMAT:**

tt,mm/dd/yyyy,HH:MM:SS,ID- vv

Where:

tt	= type, 00 - 99
mm	= month, 1 - 12
dd	= day, 1 - 31
yyyy	= year, 2000 - 2099
HH	= hours, 0 - 23
MM	= minutes, 0 - 59
SS	= seconds, 0 - 59
ID-	= Sensor number (S1, S2 or BB for both)
vv	= variable data depending on tt

**Log Entry Type Table (tt):**

Log Entry Type Code (tt)	Description
00	Boot/Power up- SensAlert IR Transmitter Information Event
01	Sensor Warm-up: New Sensor/Sensor removed and replaced Event
02	Parameter Changes Made Event
03	Alarm High-Level Triggered Event
04	Alarm Mid-Level Triggered Event
05	Alarm Low-Level Triggered Event
06	Change in Gas Level > 5% of Sensor Range Event
07	Sensor Fault/Missing/Not Identical Detected Event
08	Sensor Calibrated Event
09	Flash Cleared/Restarted Event
10	Self-Test Initiated by Operator Event
11	Self-Test Concluded by Operator Event
12	Self-Test Aborted by Operator Event
13	Sensor Cell Warning Event
14	SensAlert IR Transmitter Role Change Event
99	Flash Card Re-Inserted Event

**Log Entry Data Format For Each Type Table (vv):**

Log Entry Type Code (tt)	Log Entry Event Name <i>Log Variable Data Format (vv)</i>
00	<b>SensAlert IR Transmitter Boot/Power Up Event</b> <i>Preamble, BB- US, FWVerMaj.Min.Rev</i>
01	<b>Sensor Warm-up Event</b> <i>Preamble, ID- US, FWVerMaj.Min.Rev</i>
02	<b>Parameters Changed Event</b> <i>Preamble, ID- NID, ZID, SSN, STP, CD, CV, RNG, LOW, MID, HI, GU, GN</i>
03	<b>Alarm High-Level Triggered Event</b> <i>Preamble, ID- Gas Value Float</i>
04	<b>Alarm Mid-Level Triggered Event</b> <i>Preamble, ID- Gas Value Float</i>
05	<b>Alarm Low-Level Triggered Event</b> <i>Preamble, ID- Gas Value Float</i>
06	<b>Change in Gas Level Event</b> <i>Preamble, ID- Gas Value Float</i>
07	<b>Sensor Fault Event</b> <i>Preamble, ID- (SSC, SEC)/SMT</i>
08	<b>Sensor Calibration Event</b> <i>Preamble, ID- CALTXT</i>

09	<b>Flash Cleared Event</b> <i>Preamble, BB- "Memory Card Cleared."</i>
10	<b>Self-Test Initiated Event</b> <i>Preamble, ID- "Self Test Started."</i>
11	<b>Self-Test Concluded Event</b> <i>Preamble, ID- "Self Test Concluded."</i>
12	<b>Self-Test Aborted Event</b> <i>Preamble, ID- "Self Test Aborted."</i>
13	<b>Sensor Cell Warning Event</b> <i>Preamble, ID- CWC</i>
14	<b>3120 Unit Role Change Event</b> <i>Preamble, BB- RLM, SHR</i>
99	<b>Flash Card Re-inserted Event</b> <i>Preamble, BB- US, DVID, FWMaj, Min, Rev, RLM, SHR</i> - S1: NID, ZID, SSN, STP, CD, CV, RNG, LOW, MID, HI, GU, GN - S2: NID, ZID, SSN, STP, CD, CV, RNG, LOW, MID, HI, GU, GN
<b>Parameter Variables:</b>	
<b>Variable</b>	<b>Variable Description</b>
<i>Preamble</i>	tt,mm/dd/yyyy,HH:MM:SS
tt	Log Entry Type Code
mm	Month value (01 – 12)
dd	Day of month (01 – 31)
yyyy	Year (2000 – 2099)
HH	Hours (24 hour format, 00 – 23)
MM	Minutes (00 – 59)
SS	Seconds (00 – 59)
S1-	Literal text for sensor one (S1-)
S2-	Literal text for sensor two (S2-)
BB-	Literal text for both sensors (BB-)
ID-	Replaced with literal text (S1-, S2- or BB-) based on sensor(s) reporting on
US	SensAlert IR Transmitter Serial Number
DVID	Disk Volume ID
FWMaj	Firmware Major Version Number
Min	Firmware Minor Version Number
Rev	Firmware Revision Version Number
RLM	Relay Logic Mode (0 = first, 1 = second, 101 = AND, 102 = OR)
SHR	Sensor Head Role (0 = Identical, 1 = Unique, 2 = Single Sensor)
NID	Network ID
ZID	Network Zone ID
SSN	Sensor Serial Number
STP	Sensor Type Code (see sensor manual for codes)
CD	Sensor Last Calibration Date
CV	Calibration Value (Float)
RNG	Sensor Range Value (Float)
LOW	Alarm Low threshold Point (Float)
MID	Alarm Mid threshold Point (Float)
HI	Alarm High threshold Point (Float)
GU	Gas Units Name (4 text characters)
GN	Gas Name (8 text characters)
(SSC,SEC)/SMT	Either (Sensor Status Code, Sensor Error Code values) OR Sensor Fault Message Text
SSC	Sensor Status Code (see sensor manual for code values)
SEC	Sensor Error Code (see sensor manual for code values)
SMT	Literal text: "Sensor Missing!", or "Sensors Not Identical!"
CALTXT	Literal text: "Zeroed." or "Spanned."
CWC	Sensor Cell Warning Code (see sensor manual for code values)

### 16.1. Formatting the Flash Card (Selected from the Initial / Top Menu, Page 2)

The Flash Card may be re-formatted by the operator using the SensAlert IR Transmitter.

(WARNING: ALL contents WILL be lost!)

↑ EJECT MEMORY CARD  
ABORT WARMUP  
INFO  
↓ MAIN MENU

↑ SEC DIAGNOSTICS  
RESET RELAYS  
\* FORMAT FLASH CARD  
↓ EXIT

Select ENTER and Flash Card Format Screen will be displayed:

- FORMATTING FLASH -  
PLEASE WAIT ...  
  
-ENT- TO ABORT

CARD FORMAT  
COMPLETE ...

↑ SEC DIAGNOSTICS  
RESET RELAYS  
FORMAT FLASH CARD  
\* ↓ EXIT

Select ENTER on 'EXIT' to remove the Initial / Top menu and restore the Normal operation display.

## 17. UL 2075 EOL (END-OF-LIFE) NOTIFICATION

Per the requirement of UL 2075, second edition, revision date 08/04/2023, a UL 2075 approved product is required to have an End-Of-Life notification after no longer than 10 years of use.

When the SensAlert IR Transmitter is paired with a 0-100%LEL Methane SensAlert IR Sensor, a EOL notification, warning 139, is displayed after the detector has been running for 10 years. This lets the user know it is time to replace the sensor. See below for what an example of what this looks like:

Sensor 1:

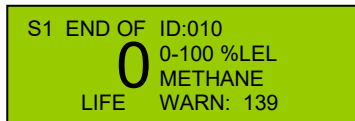

S1 END OF ID:010  
0 0-100 %LEL  
METHANE  
LIFE WARN: 139

Sensor 2

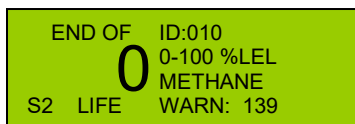

END OF ID:010  
0 0-100 %LEL  
METHANE  
S2 LIFE WARN: 139

**NOTE:** If the sensor is functioning properly, it will still read gas correctly to prevent an unsafe condition. The notification will stay active until the sensor is replaced.

Once this warning is displayed, the sensor is required to be replaced to comply with the UL 2075 standard.

## 18. FIGURES

Figure 1 – Overall Layout

Figure 2 – SensAlert IR Transmitter Wiring

Figure 3 – SensAlert IR Sensor Separation Kit

Figure 4 – Mounting SensAlert IR Transmitter and SensAlert IR Sensor

Figure 5 – Mounting SensAlert IR and SensAlert IR Tall Sensor

**NOTE: Figures 4-8 show 2 sensors of the same kind mounted on the SensAlert IR Transmitter together as an example. The SensAlert IR Transmitter can be used with 1 sensor, or 2 sensors of any kind, they do not have to be the same type of sensor.**

**For example, a SensAlert IR Transmitter can be used with a SensAlert IR Sensor mounted on the side and a SensAlert IR Tall Sensor mounted on the bottom.**

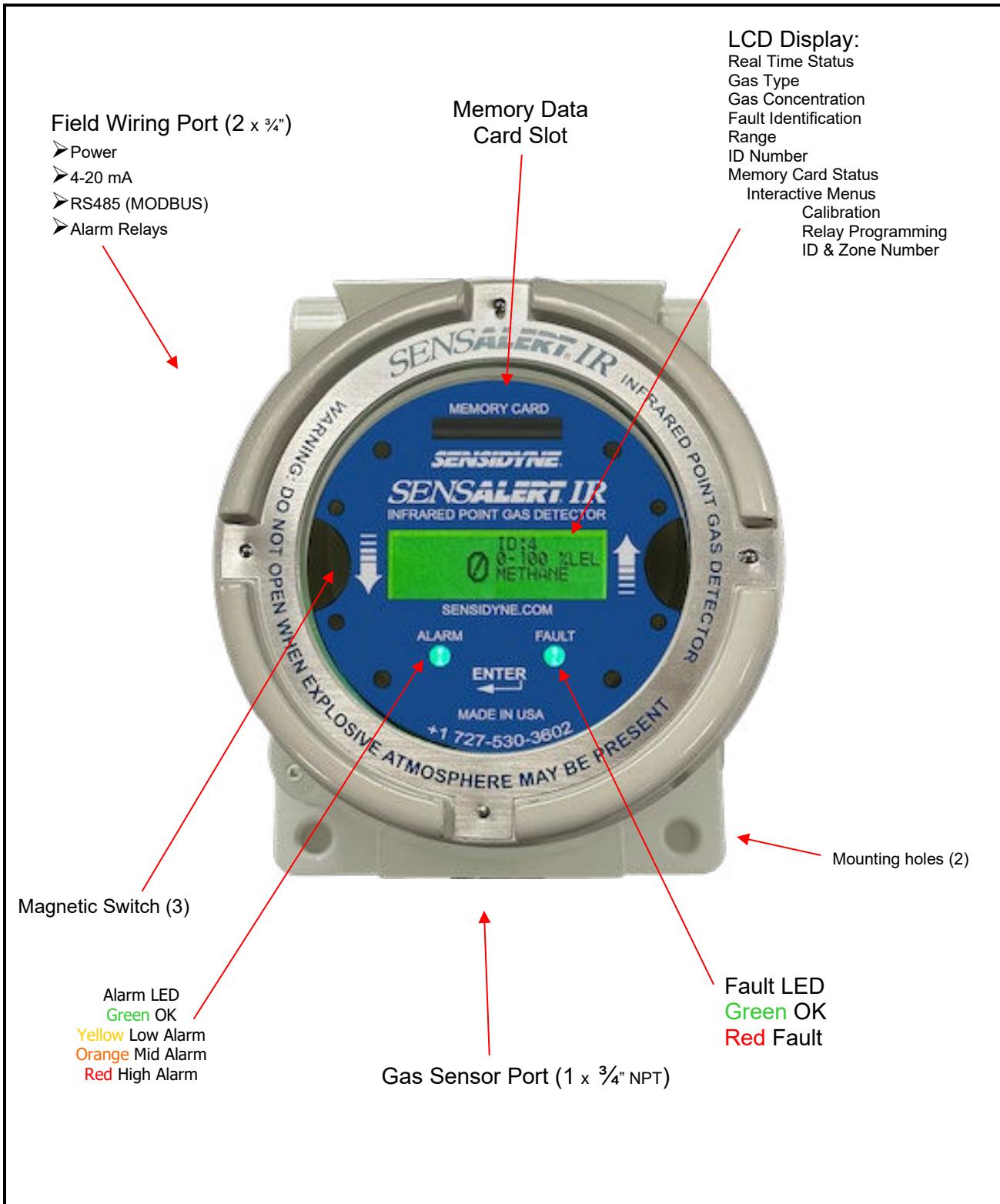

Field Wiring Port (2 x 3/4")

- Power
- 4-20 mA
- RS485 (MODBUS)
- Alarm Relays

Memory Data Card Slot

LCD Display:

- Real Time Status
- Gas Type
- Gas Concentration
- Fault Identification
- Range
- ID Number
- Memory Card Status
- Interactive Menus
- Calibration
- Relay Programming
- ID & Zone Number

Magnetic Switch (3)

- Alarm LED
- Green OK
  - Yellow Low Alarm
  - Orange Mid Alarm
  - Red High Alarm

Gas Sensor Port (1 x 3/4" NPT)

- Fault LED
- Green OK
  - Red Fault

Mounting holes (2)

Sensidyne, LP  
 1000 112<sup>TH</sup> Circle N, Suite 100  
 St. Petersburg, Florida 33716 USA  
 Tel: 800-451-9444 / +1 727-530-3602 • Fax: +1 727-539-0550 [fax]  
 web: [www.Sensidyne.com](http://www.Sensidyne.com) • [www.SensidyneGasDetection.com](http://www.SensidyneGasDetection.com)  
 e-mail: [info@Sensidyne.com](mailto:info@Sensidyne.com)

**Figure 1 – SensAlert IR Transmitter Overview**

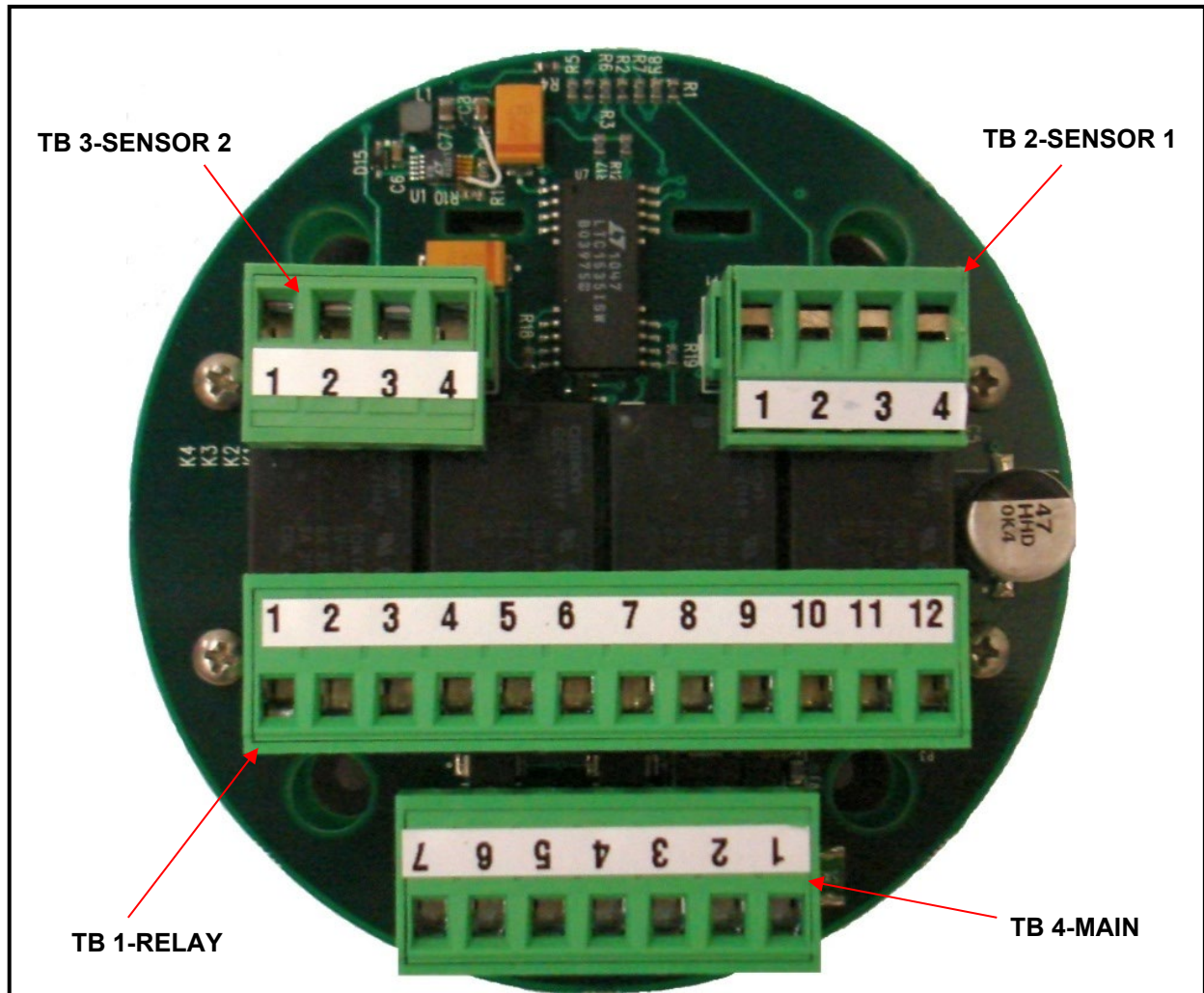

**TB 1 – RELAYS**

- (12) FAULT (N.E.) N.C.
- (11) FAULT (N.E.) COMMON
- (10) FAULT (N.E.) N.O.
- (9) HIGH ALARM N.C.
- (8) HIGH ALARM COMMON
- (7) HIGH ALARM N.O.
- (6) MID ALARM N.C.
- (5) MID ALARM COMMON
- (4) MID ALARM N.O.
- (3) LOW ALARM N.C.
- (2) LOW ALARM COMMON
- (1) LOW ALARM N.O.

NC = NORMALLY CLOSED  
 NO = NORMALLY OPEN

**TB 2 – SENSOR 1**

- (1) WHITE (DATA/CAL)
- (2) BLUE OR GREEN (4-20 mA)
- (3) RED (+24 VDC)
- (4) BLACK (DC COMMON)

**TB 3 – SENSOR 2**

- (1) WHITE (DATA/CAL)
- (2) BLUE OR GREEN (4-20 mA)
- (3) RED (+24 VDC)
- (4) BLACK (DC COMMON)

**TB 4 – MAIN**

- (1) +24 VDC
- (2) 4-20 mA SENSOR 1
- (3) DC COMMON
- (4) RS485 DATA B
- (5) RS485 DATA A
- (6) ISOLATED COMMON
- (7) 4-20 mA SENSOR 2

Sensidyne, LP  
 1000 112<sup>TH</sup> Circle N, Suite 100  
 St. Petersburg, Florida 33716 USA  
 Tel: 800-451-9444 / +1 727-530-3602 • Fax: +1 727-539-0550 [fax]  
 web: [www.Sensidyne.com](http://www.Sensidyne.com) • [www.SensidyneGasDetection.com](http://www.SensidyneGasDetection.com)  
 e-mail: [info@Sensidyne.com](mailto:info@Sensidyne.com)

**Figure 2 – Back View of SensAlert IR Transmitter Wiring**

SensAlert IR Transmitter

	Black	Red	Blue	White	Yellow	Brown
SensAlert IR Sensor	1	2	3	4	N/A	N/A
	-	+	Analog Out	Comm	Analog Out	Pressure Comp

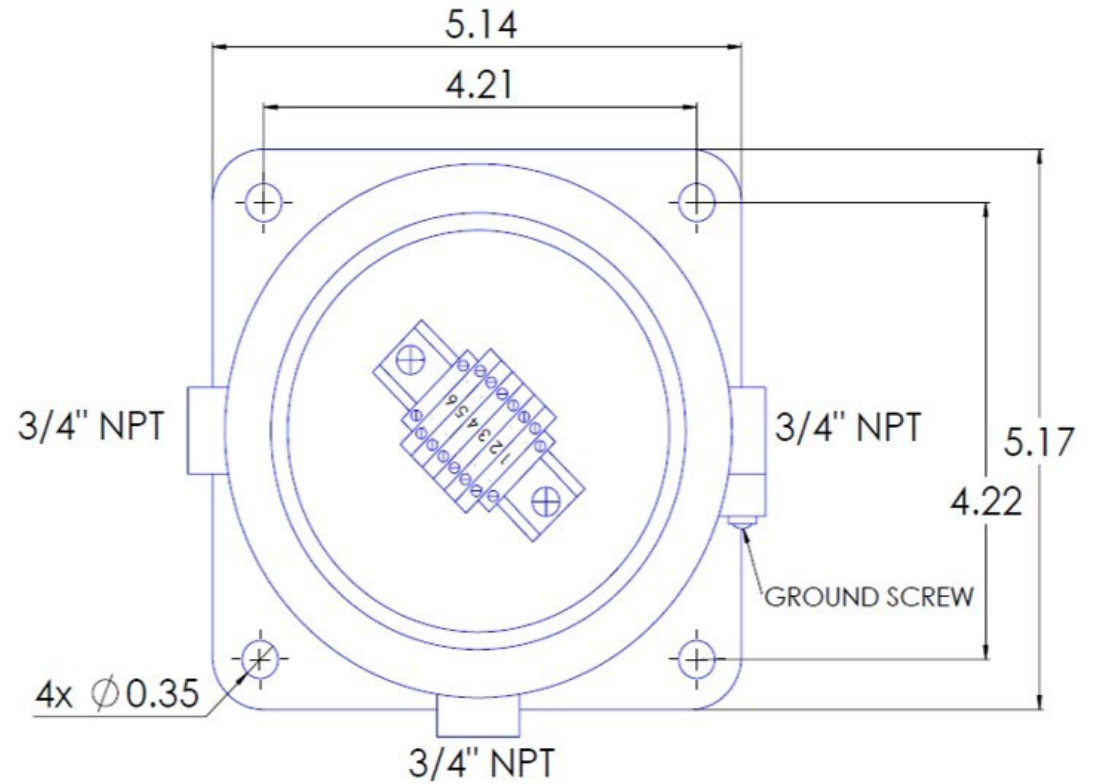

1. NOTES:  
Class I, Div I Group B, C & D  
Ex d IICC GB
2. TERMINALS: 6
3. HEIGHT: 4.11" COVER INSTALLED
4. GROUND SCREW ALSO LOCATED UNDER TERMINAL BLOCK

**Figure 3 – SensAlert IR Sensor Separation Kit**

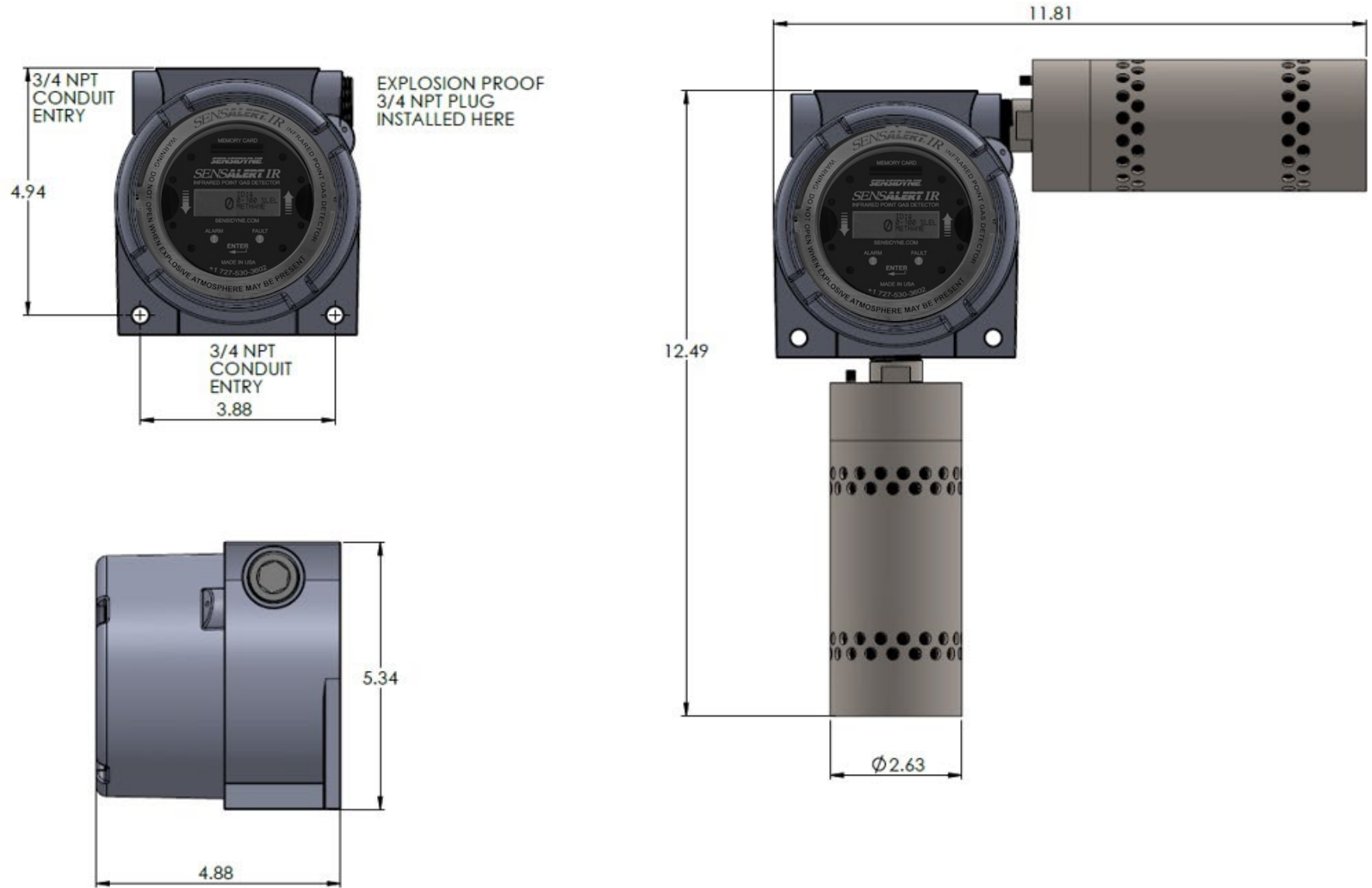

Figure 4 - Mounting SensAlert IR Transmitter and SensAlert IR Sensor

SensAlert IR Transmitter

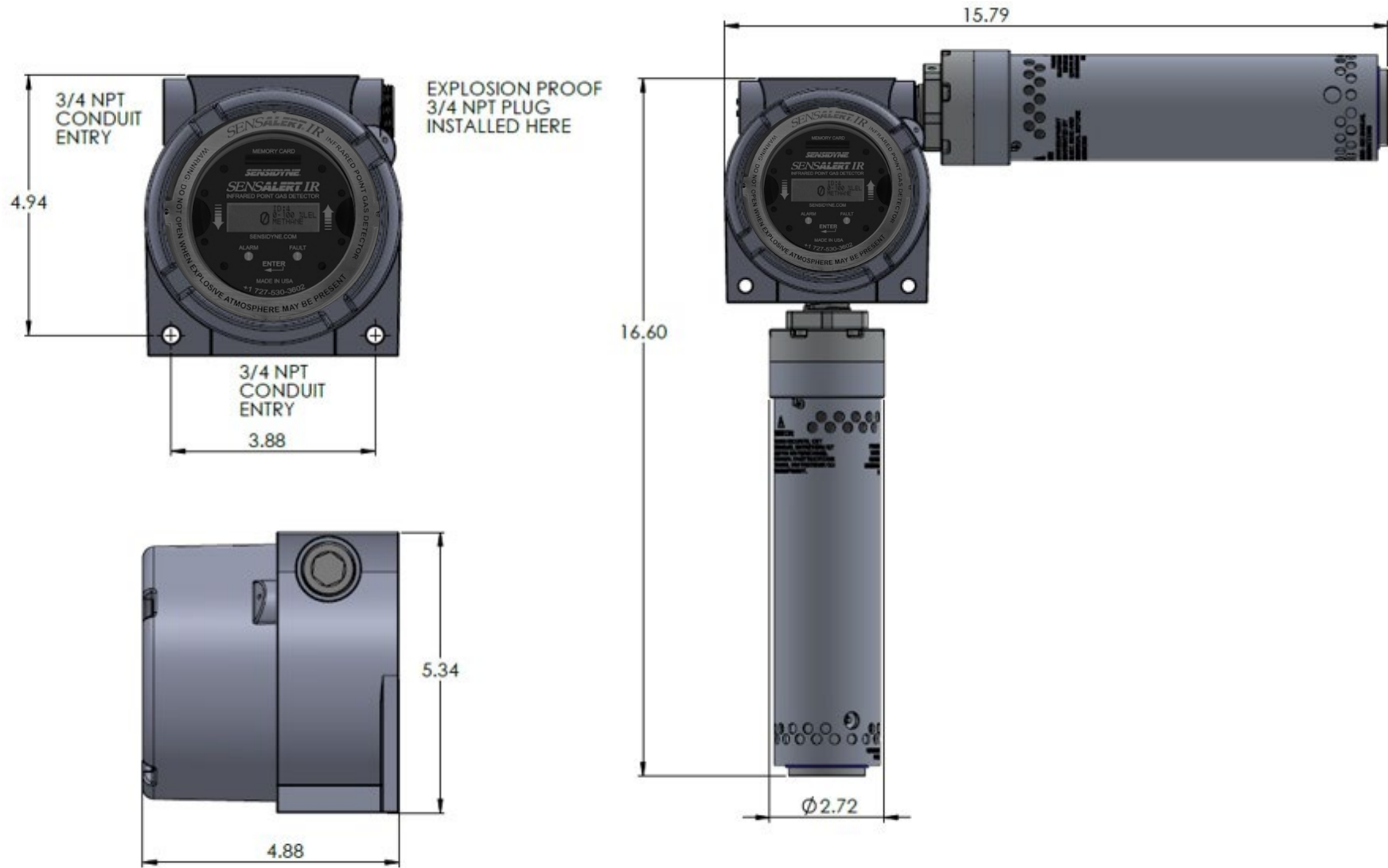

Figure 5 - Mounting SensAlert IR Transmitter and SensAlert IR Tall Sensors

## 19. UNIT STATUS FLASH CODES

Flash Rate	Output Current	PC Reads (Hex)	Status Code (Dec)	Unit Status Label	Description
1	4-20ma	0x00	0	Unit Running	Unit is measuring gas and adjusting 4-20ma output accordingly.
2	2.2ma	0x02	2	Unit Zero Calibrating	Unit goes through its <i>zero calibration</i> procedure.
3	2.0ma	0x03	3	Unit Spanning	Unit goes through its <i>spanning</i> procedure.
4	0-20ma	0x04	4	Unit 4-20ma Calibrating	Unit goes through its <i>4-20ma-calibration</i> procedure. (Factory Only)
5	0.8ma	0x05	5	Unit Warm-up	Unit is warming up.
6	0.0ma	0x06	6	Power-up Fault	Unit has determined a <i>Power-Up</i> fault condition.
7	1.6ma	0x07	7	Calibration Fault	Unit has determined an error during <i>calibration</i> procedure.
8	NA	0x08	8	NA	Currently Not Used
9	0.0ma	0x09	9	Unit Fault	Unit has determined a <i>Unit_Fault</i> condition.
10	1.0ma	0x0a	10	Optics Fault	Unit has determined an <i>Optics_Fault</i> condition.
11	1.2ma	0x0b	11	Zero Drift Fault	Unit has determined a <i>Zero_Drift_Fault</i> condition.
12	0.0ma	0x0c	12	Configuration Fault	Unit has never been <i>Zeroed</i> , <i>Spanned</i> , <i>Source</i> calibrated, or E <sup>2</sup> has a Header byte error.
13	1.4ma	0x0d	13	Hot Zero Calibration	Unit goes through its <i>Hot Temperature calibration</i> procedure. (Factory Only)
14	1.4ma	0x0e	14	Cool Zero Calibration	Unit goes through its <i>Cool Temperature calibration</i> procedure. (Factory Only)
15	4mA->20mA	0x0f	15	Self Test	Unit generates zero to full scale output (4-20mA & Norm Gas Level)
16	0.2ma	0x10	16	Reference Channel Fault	AGC Potentiometer reaches the minimum predetermined value during the unit AGC procedure.

SensAlert IR Transmitter

17	0.4ma	0x11	17	Active Channel Fault	Balance Potentiometer reaches the minimum or maximum predetermined value during the unit Calibration procedure.
18	N/A	0x12	18	Power Fault	24VDC < 18 or 24VDC >32V
19	N/A	0x13	19	Comp Zeroing	
20	N/A	0x14	20	Comp Spanning	
21	N/A	0x15	21	Fixed 4mA	
22	N/A	0x16	22	Fixed 20mA	

## 20. UNIT ERROR CODES

Error Code Label's	Error Code Value's	Error Code (Dec)	Error Code Description's	Unit Status
NO_ERROR	0x00	0	Unit is measuring gas and operating properly	Unit Running
ERR_EEPROM_HEADER_BYTE	0x01	1	EEPROM does not have correct header byte stored.	Configuration Fault
ERR_EEPROM_CHKSUM	0x02	2	Checksum byte from EEPROM does not match calculated checksum on latest EEPROM read..	Configuration Fault
ERR_NO_ZERO_YET	0x03	3	Unit has yet to be zero calibrated.	Configuration Fault
ERR_NO_SPAN_YET	0x04	4	Unit has yet to be spanned.	Configuration Fault
ERR_ZERO_VALUES	0x05	5	Zero values are out of specification limits.	Power-up Fault
ERR_420_CALIB1	0x06	6	When searching for >4vdc level during the 4-20ma calibration procedure, it was unsuccessful in the first three attempts.	Power-up Fault
ERR_420_CALIB2	0x07	7	When searching for the exact 4vdc level during the 4-20ma calibration procedure, it was unsuccessful in the first four attempts.	Power-up Fault
ERR_SIGNAL_HIGH	0x08	8	When the signal level is greater than 4.75vdc at the time it is read during the AGC procedure.	Zero Drift Fault
ERR_4VDC_REF_LOW	0x09	9	When the internal reference voltage is too low.	Unit Fault
ERR_4VDC_REF_HIGH	0x0A	10	When the internal reference voltage is too high.	Unit Fault
ERR_BAL_POT_MAX	0x0B	11	When the Balance digital potentiometer reaches the maximum predetermined value during the unit calibration procedure.	Calibration Fault
ERR_BAL_POT_MIN	0x0C	12	When the Balance digital potentiometer reaches the minimum predetermined value during the unit calibration procedure.	Calibration Fault

SensAlert IR Transmitter

ERR_AGC_POT_MAX	0x0D	13	When the AGC digital potentiometer reaches the maximum predetermined value during the unit AGC procedure.	Optics Fault
ERR_AGC_POT_MIN	0x0E	14	When the AGC digital potentiometer reaches the minimum predetermined value during the unit AGC procedure.	Ref Channel Fault
ERR_SPAN_POT_MAX	0x0F	15	When the Span digital potentiometer reaches the maximum predetermined value during the unit span procedure.	Calibration Fault
ERR_SPAN_POT_MIN	0x10	16	When the Span digital potentiometer reaches the minimum predetermined value during the unit span procedure.	Calibration Fault
ERR_NO_HOT_ZERO_YET	0x11	17	Unit has yet to be zeroed while Hot.	Configuration Fault
ERR_NO_COOL_ZERO_YET	0x12	18	Unit has yet to be zeroed while Cool.	Configuration Fault
ERR_UNIT_TEMP_HIGH	0x13	19	Unit Temperature is over the specified upper limit.	Unit Fault
ERR_UNIT_TEMP_LOW	0x14	20	Unit Temperature under the specified lower limit.	Unit Fault
ERR_ANALYTICAL_RANGE	0x15	21	Insufficient Analog Range during spanning	Calibration Fault
ERR_NO_TABLE_YET	0x16	22	Unit has yet to down load a table via the PC and Comm_Link.	Configuration Fault
ERR_SPAN_NO_LONGER_VALID	0x17	23	Range has been changed	Cal Fault
ERR_SPAN_POT_OVERFLOW	0x18	24	Not enough Span pot room for temperature comp. (Span Gain too high)	Cal Fault
ERR_24VDC_LOW	0x19	25	24VDC too Low	Unit Fault
ERR_24VDC_HIGH	0x1A	26	24VDC too High	Unit Fault
PRESSURE_FAULT	0x1B	27	No Pressure Sensor Input	Unit Fault
FAULT_EXTERNAL	0x1C	28	LIM (Fault Version) Either input Active...External Fault Condition	Unit Fault

ERR_RD_PRES	0x1D	29	SensAlert IR Tall Sensor. No response from MPL115A2	Unit Fault
-------------	------	----	---	------------

Revision	Description
A	Initial Release
-	-

***SENSIDYNE***<sup>®</sup>

Sensidyne, LP

1000 112<sup>th</sup> Circle N, Suite 100

St. Petersburg, Florida 33716 USA

800-451-9444 • +1 727-530-3602 • +1 727-539-0550 [fax]

web: [www.sensidyne.com](http://www.sensidyne.com) • e-mail: [info@sensidyne.com](mailto:info@sensidyne.com)