

SENSALERT® IR

Infrared Hydrocarbon Gas Detectors



Instruction and Operation Manual

Document No. 360-2101-01 Rev A

SENSIDYNE®

Sensidyne, LP • 1000 112th Circle N, Suite 100
St. Petersburg, Florida 33716 USA
800-451-9444 • +1 727-530-3602 • +1 727-539-0550 [fax]
web: www.sensidyne.com • e-mail: info@sensidyne.com

Sensidyne, LP

Sensidyne, LP designs and manufactures innovative fixed system gas detection equipment, for combustible gases, oxygen, carbon dioxide and toxic gases.

Commitment

Our quality and service are uncompromising. We back the SensAlert IR with a five-year warranty on all materials and workmanship. We offer technical support, user training and on-site service and maintenance of equipment to meet the needs of our customers.

Gas Detection Service

Individually designed maintenance packages are available for specific customer needs. Service begins with verification of the system installation that includes an initial system check and calibration. We then offer customer training programs (on-site and at factory) to ensure that technical personnel fully understand operation and maintenance procedures. When on-the-spot assistance is required, service representatives are available to handle any questions or problems immediately.

WARRANTY

SENSIDYNE, LP WARRANTS SENSALERT IR PROVIDED BY SENSIDYNE, LP TO BE FREE FROM DEFECTS IN WORKMANSHIP AND MATERIALS FOR A PERIOD OF FIVE (5) YEARS FROM DATE OF SHIPMENT FROM THE FACTORY. ANY PARTS RETURNED FREIGHT PRE-PAID TO THE FACTORY AND FOUND DEFECTIVE WITHIN THE WARRANTY WOULD BE REPAIRED OR REPLACED, AT SENSIDYNE, LP OPTION. SENSIDYNE, LP WILL RETURN REPAIRED OR REPLACED EQUIPMENT PRE-PAID LOWEST COST FREIGHT. THIS WARRANTY DOES NOT APPLY TO ITEMS, WHICH BY THEIR NATURE ARE SUBJECT TO DETERIORATION OR CONSUMPTION IN NORMAL SERVICE. WARRANTY IS VOIDED BY ABUSE INCLUDING ROUGH HANDLING, MECHANICAL DAMAGE, ALTERATION OR REPAIR. THIS WARRANTY COVERS THE FULL EXTENT OF SENSIDYNE, LP LIABILITY AND SENSIDYNE, LP IS NOT RESPONSIBLE FOR REMOVAL, REPLACEMENT COSTS, LOCAL REPAIR COSTS, TRANSPORTATION COSTS OR CONTINGENT EXPENSES INCURRED WITHOUT PRIOR WRITTEN APPROVAL. SENSIDYNE, LP OBLIGATION UNDER THIS WARRANTY SHALL BE LIMITED TO REPAIR OR REPLACEMENT OF ANY PRODUCT THAT HAS BEEN RETURNED TO SENSIDYNE, LP FOR WARRANTY CONSIDERATION. THIS WARRANTY IS EXPRESSLY IN LIEU OF ANY AND ALL OTHER WARRANTIES EXPRESSED OR IMPLIED, AND ALL OTHER OBLIGATIONS OR LIABILITIES ON THE PART OF SENSIDYNE, LP INCLUDING BUT NOT LIMITED TO, THE FITNESS FOR A PARTICULAR PURPOSE. IN NO EVENT SHALL SENSIDYNE, LP BE LIABLE FOR DIRECT, INCIDENTAL, OR CONSEQUENTIAL LOSS OR DAMAGE OF ANY KIND CONNECTED WITH THE USE OF IT'S PRODUCTS OR FAILURE TO FUNCTION OR OPERATE PROPERLY.



WARNING: READ AND UNDERSTAND THE USER'S MANUAL BEFORE OPERATING OR SERVICING

LISEZ ET COMPRENEZ LE MANUEL DE L'UTILISATEUR AVANT D'UTILISER OU D'ENTRETENIR



WARNING: OPEN CIRCUIT BEFORE REMOVING COVER
OUVRIR LE CIRCUIT AVANT D'ENLEVER LE COUVERCLE



CAUTION: FOR SAFETY REASONS THIS EQUIPMENT MUST BE OPERATED AND SERVICED BY QUALIFIED PERSONEL ONLY

ATTENTION : POUR DES RAISONS DE SÉCURITÉ, CET ÉQUIPEMENT DOIT ÊTRE UTILISÉ ET RÉPARÉ UNIQUEMENT PAR DU PERSONNEL QUALIFIÉ

I. TABLE OF CONTENTS

Contents

I. TABLE OF CONTENTS	4
II. SPECIFICATIONS	5
III. GENERAL DESCRIPTION	7
IV. OPERATION	9
V. CALIBRATION	12
VI. MAINTENANCE	15
VII. DRAWING SECTION	17
VIII. UNIT STATUS FLASH CODES	23
IX. UNIT ERROR CODES	25

II. SPECIFICATIONS

Model:

Sensidyne, LP SensAlert IR Sensor Infrared Hydrocarbon Gas Detector

Available gases:

Methane	Hexane	Jet A	Toluene
Ethane	Diesel	Ethanol	P-Xylene
Ethylene	Gasoline	Methanol	Tert-Butyl Acetate
Ethylene Oxide	Green Earth	Butane	MEK
Propane	DF 2000	Hexane	

NOTE: This list is not all-inclusive. The SensAlert IR Sensor can be calibrated for most hydrocarbons, provided a calibration gas is available. For more please contact Sensidyne, LP.

NOTE: The SENSALERT IR SENSOR is only 100% accurate to the target gas on the label. It will not accurately read other gasses but may still respond to them. The SensAlert IR Sensor is meant to be a single gas sensor.

Detection Method:

Diffusion

Optional sample draw (requires a minimum of 1 liter per minute flow rate)

Output (analog):

4-20 mA (Source type), max. 1000 Ohm load at 24 VDC supply voltage

Response Time:

Standalone

T50 < 5 seconds

T90 < 10 seconds

Connected to SensAlert IR Transmitter

T50 < 6 seconds

T90 < 11 seconds

Construction:

316 Stainless Steel

Or

6061 Aluminum (Anodized)

Accuracy:

+/- 3% LEL, 0 to 50% LEL (Lower Explosive Limit)

+/- 5% LEL, 51 to 100% LEL

Operating Temperature Rating:

-40° to +70°C at 0 to 99% RH (non-condensing)

Operating Pressure:

Performance tested to 11.6 PSIA to 17.4 PSIA (Pounds Per Squar Inch Absolute)

Note: Due to pressure induced gas density changes, the SensAlert IR Sensor will have some deviation in its readings the further away from 14.7psia ambient pressure.

Storage Conditions:

SensAlert IR Sensor Detector and Parts in Outlined in Section **Error! Reference source not found.:** 0° to 40°C at 0 to 99% RH (non-condensing), 11.6 PSIA to 17.4 PSIA for 10 years

SensAlert IR Sensor

Operating Voltage:

24 VDC $\overline{=}$ $\overline{=}$ Operating range: 18 to 32 VDC measured at the detector head

Power Consumption: 3.6 Watts Max.

Current Draw:

At 24 VDC Average: 85 mA Peak: 150 mA

At 18 VDC Average: 135 mA Peak: 200 mA

Weight:

5 lbs (2.3kg) Stainless Steel

2 lbs (0.9kg) Aluminum

Approvals:

Explosion Proof: Class I, Division 1, Groups B, C and D, Temp T5; -40C to +70C

Combustible Gas Performance: C22.2 60079-29-1 (0-100% LEL Methane, Connected to SensAlert IR Single or Dual Transmitter)

(Pending) UL 2075, Methane 0-100%LEL Only (Conforms to UL2075, Intertek Listed)
(UL2075 Listing requires the use of the SensAlert IR Dual Transmitter)

IP 66 Rating

Note: IP ratings do not imply that the equipment will detect gas during and after exposure to those conditions. If the SensAlert IR Sensor is exposed to powerful water jets, the optics must be cleaned as outlined in section VII and a calibration performed.

Installation Category: Cat. I, Pollution Degree 2

III. GENERAL DESCRIPTION

CONVENTIONS

The following conventions are used in this manual.



Warning or Caution Statement

=== VDC (DC Voltage)

SENSALERT IR SENSOR

The SensAlert IR Sensor Infrared gas detector is a microprocessor based intelligent gas detector that continuously monitors combustible hydrocarbon gases and vapors within the Lower Flammable Limit (LFL).

The SensAlert IR Sensor is ideally suited for use in harsh environments and where the cost of required maintenance for conventional catalytic detectors is prohibitive. The SensAlert IR Sensor Infrared gas detector will perform reliably in the presence of silicone and other catalytic poisoning agents and can also operate in oxygen free environments or where high background gas levels are present. There are no known poisons that affect this technology.

The SensAlert IR Sensor is a stand-alone device providing a continuous 4 to 20 mA output.

Features

- Requires no routine calibration to ensure proper operation.
- Continuous self-test automatically indicates a fault, with fail to safe operation.
- A multi-layered filtering system protects optics from dirt and water ingress.
- Straight optical path eliminates the need for mirrors or reflective surfaces, such as mirrors or beam splitters.
- Performs well in the presence of high concentrations or constant background levels of hydrocarbons and in oxygen depleted atmospheres.
- Highly resistant to poisoning and etching.
- Standard 4 to 20 mA output (current source)
- Explosion proof housing designed for harsh environments.
- Smart Calibration AutoAC™ circuit.

Infrared Detection Technology

The SensAlert IR Sensor Infrared gas detector uses infrared absorption technology for detecting combustible hydrocarbon gases. Gases absorb infrared light only at certain wavelengths. The concentration of a gas can be measured by the difference of two channels (wavelengths), a reference and a measurement (absorption) channel. The SensAlert IR Sensor uses a collimated infrared light source that passes through a waveguide, at the end of the waveguide is a dual channel receiver. The dual channel receiver measures the intensity of two specific wavelengths, one at an absorption wavelength and another outside of the absorption wavelength. The gas concentration is determined by a comparison of these two values.

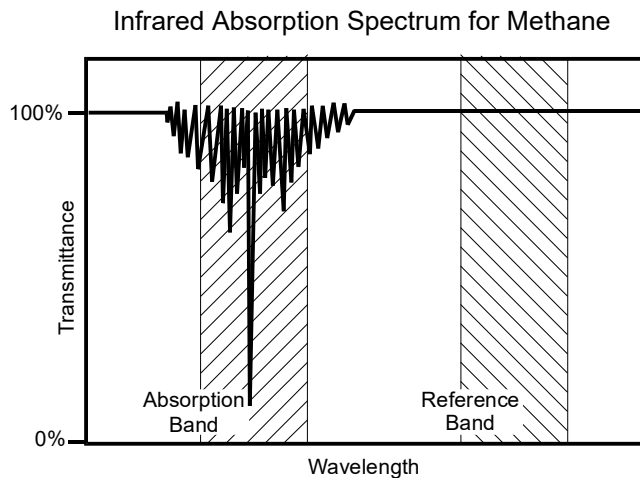

The dual channel receiver is a single wafer, double filtered, dual receiver with an internal optical barrier. The elements are perfectly matched resulting in overall stability and superior performance throughout the entire temperature range.

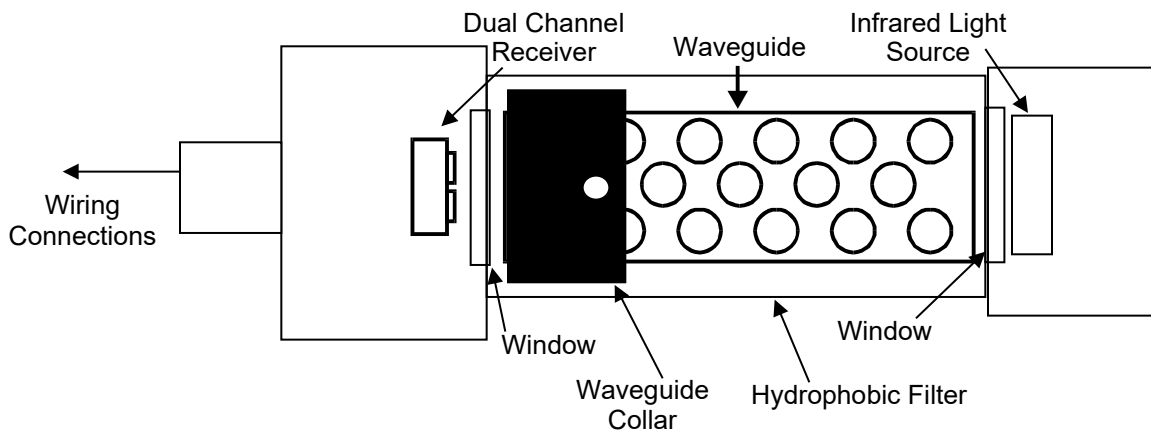

Using a dual channel receiver there is no need to use any special lenses or beam splitters to achieve the different measurement bands.

The SensAlert IR Sensor utilizes a unique, patented feature; the AutoAC™ circuit. The AutoAC™ circuit is an automatic analog control circuit, which allows the SensAlert IR Sensor to be calibrated for any combustible hydrocarbon, provided that a calibration quality level of the gas is available. This eliminates setting dipswitches or changing out sensors for different types of hydrocarbons, simply calibrate the unit with a calibration gas of the specific gas to be detected.

The optics can be easily disassembled for cleaning. This does not require powering the unit down and does not compromise the units' explosion proof rating. The device will self-compensate for dirty optics until a point in which the optical surfaces are completely obscured.

There are no consumable components contained in this product.

Due to the nature of IR technology, O₂ is not required to sense gas. The concentration of O₂ in the atmosphere does not affect the reading.

IV. OPERATION

Installation and Startup



Warning: If the equipment is used in a manner not specified by the manufacturer, the protection provided by the equipment may be impaired.

The first step in the installation process is to establish a mounting location for the SensAlert IR Sensor. Select a location that is typical of the atmosphere to be monitored or close to the anticipated source of a dangerous gas.

It is very important that the SensAlert IR Sensor be properly located to enable it to provide maximum protection. The most effective number and placement of sensors vary depending on the conditions of the application. When determining where to locate sensors the following factors should be considered.

- What are the characteristics of the gas that is to be detected? Is it lighter or heavier than air? If it is lighter than air the sensor should be placed above the potential gas leak. Place the sensor close to the floor for gases that are heavier than air or for vapors resulting from flammable liquid spills. Note that air currents can cause a gas that is heavier than air to rise. In addition, if the temperature of the gas is hotter than ambient air or mixed with gases that are lighter than air, it could also rise.
- How rapidly will the gas diffuse into the ambient air? Select a location for the sensor that is close to the anticipated source of a gas leak.
- Wind or ventilation characteristics of the immediate area must also be considered. Movement of air may cause gas to accumulate more heavily in one area than in another. The detector should be placed in the areas where the most concentrated accumulation of gas is anticipated. For outdoor applications with strong wind conditions, it may require the sensors to be mounted closer together and on the downwind side, to the anticipated area of a gas leak. Also take into consideration for indoor applications, the fact that many ventilation systems do not operate continuously.
- The sensor should be accessible for maintenance.
- Excessive heat or vibration can cause premature failure of any electronic device and should be avoided if possible.
- Follow all national and local installation codes and practices.

The SensAlert IR Sensor has a 3/4" NPT threaded connector for mounting the detector to a junction box. Sensidyne can provide a junction box with terminals for this purpose. A thread lubricant is recommended on the 3/4 NPT threads to prevent seizing in case of removal. The thread engagement shall be at least 5 full threads. Corrosion inhibiting grease may be used if it is non-setting and if earthing/grounding between the certified metallic junction box and detector is maintained.

The bonding connection on the cap of the detector must provide an effective connection for earthing/grounding. This is done by using a conductor of at least 4 mm². It is acceptable to use suitable wiring lugs for installation if necessary. It is the user's responsibility to ensure that the earth continuity of the equipment is maintained via the mounting arrangement. Each SensAlert IR Sensor comes with a nut and lock washer on the earth ground stud.

A user-supplied junction box can be used providing it has the appropriately sized NPT conduit entries. The junction box must be suitable for use in the application and location in which it is being installed.

The detector may be mounted in either a horizontal or vertical orientation.

After the device has been installed, a zero calibration is required. Refer to the Calibration section of this manual.

Interfering Gasses:

Because the SensAlert IR Sensor is an optical based detector, it cannot be poisoned. However, it will respond to many hydrocarbons other than what it has been calibrated to.

Wiring connections

Red wire: 18 to 32 VDC ===

Black wire: DC Common

Blue wire: 4 to 20 mA output

White wire: Smart Calibration Wire (data wire)

Earth Ground: Male 10-32 Stud on SensAlert IR Sensor cap, see figure 1.

Wire sizing:

0 to 500 feet, recommended wire gauge size 16 AWG

500 feet is the maximum length of wire from the power supply to the SensAlert IR Sensor

Shielded cable is recommended. Wiring should be installed in metal conduit with no other cabling in the same conduit.

Wire Temperature Rating:

Greater than or equal to 70°C

Power Supply:

The SensAlert IR Sensor must be powered using a power supply rated for CAN/CSA C22.2 No. 61010-1-12 and ANSI/UL 61010-1 OR a class 2 power supply as defined in Canadian Electrical Code C22.1 Section 16-200 and/or National Electrical Code article 725.121.

Warmup

When power is applied to the detector, it enters a one (1) minute warm-up mode. The output current will be 4.0 mA during the warmup period. At the end of the warm-up period with no faults present, the detector automatically enters the normal operating mode and continues to show 4 mA. If a fault is present after warm-up, the detector current output will indicate a fault. See the following chart for fault code status.

Note: After the SensAlert IR Sensor has been installed and finished its warmup, wait at least 1 hour before issuing a zero calibration.

Normal

In the normal operating mode, the 4-to-20 mA signal levels correspond to the detected gas concentration. The detector continuously checks for system faults or initiation of calibration and automatically changes to the appropriate mode. If the unit detects the measured gas has gone outside its operating range, it will display warning 140 on a SensAlert IR Single or Dual Transmitter.

The 4 to 20 mA output of the SensAlert IR Sensor is a non-isolated current source.

EOL Notification (End of Life)

As required by the UL 2075 standard, after 10 years of run time, the SensAlert IR Sensor displays warning 139 when connected to a SensAlert IR Single or Dual Transmitter. This indicates that that the unit has reached the end of its 10-year lifespan and should be replaced. The unit will continue to read gas until it is replaced. Contact Sensidyne for more details.

Current Output and Corresponding Status

<u>Current Output</u>	<u>Status.</u>
4-20 mA	Normal measuring mode
0.0 mA	Unit Fault
0.2 mA	Reference channel fault
0.4 mA	Analytical channel fault
4.0 mA	Unit warm up
1.0 mA	Optics fault
1.2 mA	Zero drift fault
1.6 mA	Calibration fault
2.0 mA	Unit spanning
2.2 mA	Unit zeroing
4.0 mA	Zero gas level (0%LEL)
5.6 mA	(10%LEL)
8.0 mA	(25%LEL)
12 mA	(50%LEL)
16 mA	(75%LEL)
20 mA	Full scale (100% LEL)
20.1- 21 mA	Over-range (> 100% LEL)

Once the fault is cleared the SensAlert IR Sensor will automatically resume normal operation. See sections IX and X for more details on unit status and errors.

V. CALIBRATION

The SensAlert IR Sensor is factory calibrated; zeroed and spanned. *Unlike catalytic sensors it does not require routine span gas calibration to ensure proper operation.*

The SensAlert IR Sensor can be calibrated for almost any hydrocarbon using a calibration gas of the hydrocarbon that is to be detected (target gas). The SensAlert IR Sensor is required to be spanned with gas only one time with the target gas. Typically, this is done at the factory, but it is possible to field span the device by either connecting the SensAlert IR Sensor to a computer and using a software package provided by Sensidyne or, by using a Sensidyne transmitter (SensAlert IR Single or Dual Transmitter). Please contact the factory for further details.

Sensidyne offers all calibration equipment necessary to do both a zero and span calibrations.

Contact Sensidyne for more details.

NOTE: If a field span calibration is to be done, a zero calibration must occur first. Failure to do so may result in a fault or improper gas readings.

Zero Calibration:

A typical field calibration only requires the use of zero air (or 99.99% nitrogen). *If the sensor is in an area that is known to be free of hydrocarbon gases, then ambient air can be used as a zero reference.*

If zero air is used for the calibration, there is a fitting on the bottom of the sensor for a 1/8" ID tubing connection.

Before beginning calibration, connect the regulator to the zero-air bottle and use the SensAlert IR Sensor Insulation Tube to cover outer cylinder holes of the detector. Then, connect the zero air to the sensor's calibration port with the appropriate tubing. Open the zero air and let it flow for a minimum of 3 minutes. This time may need to be longer depending on the tube length from the gas bottle to the sensor. Contact Sensidyne if unsure.

To enter into the calibration mode the calibration wire must be connected to DC common (common of the power supply) for ten (10) to twenty (20) seconds, upon release the sensor will automatically enter the zero calibration routine. The electronics will automatically adjust the sensor's signal to the new zero reference level. (Applying span gas is not necessary because of the SensAlert IR Sensor unique software algorithms). During the zero calibration, routine, the current output of the SensAlert IR Sensor will go to 2.2 mA.

Although this can be accomplished manually, installation of a switch (contact closure) can accomplish the zeroing procedure. It is recommended that this switch be a momentary type switch to prevent it from inadvertently being left in the calibrate position. If after twenty (20) seconds the calibration lead has not been removed from common, the SensAlert IR Sensor will ignore the signal and continue operation as normal.

If using a SensAlert IR Single or Dual Transmitter, consult the appropriate manual on how to issue the zero calibration.

If no span calibration or "bump" test is required, the insulation tube can be removed.

Span Calibration:

With the insulation tube still covering outer cylinder holes and the tubing still connected to the bottom fitting of the SensAlert IR Sensor, disconnect the regulator from zero air and connect it the calibration gas. Open the regulator and allow the calibration gas to flow for a minimum of 3 minutes. This time may need to be longer depending on the tube length from the gas bottle to the sensor. Contact Sensidyne if unsure.

If using a SensAlert IR Single or Dual Transmitter for span calibration, consult the appropriate manual on how to issue the span calibration.

The SensAlert IR Sensor can be spanned in the field if the customer wishes to change the target hydrocarbon gas. Please contact factory for additional equipment information and pricing.

Calibration Frequency

Function of environment

The SensAlert IR Sensor requires a zero calibration after install. It is then recommended to zero the sensor 90 days (3 months) after installation, and then every 180 days (6 months). After each zero calibration the end user can perform a “bump” test with the span gas to make sure the sensor is reading accurately. If the user is satisfied with the result of the bump test, no span calibration is required.

VI.

VII. MAINTENANCE

The SensAlert IR Sensor does not normally require cleaning of the optics. However, if the unit is operating in a very dirty or dusty environment the optical path might become obscured. If the obscuration is severe enough to affect the unit's accuracy, the unit will activate an "Optics Fault" or "Zero Drift Fault".

To clear the fault, first try a calibration. If the calibration does not correct the fault condition, try to clean the optics.

Cleaning the Optics:

The outer barrel (tube with two sets of holes) can be removed (unscrewed) to inspect the cleanliness of the hydrophobic filter. The hydrophobic filter is a Teflon coated stainless steel mesh that keeps moisture and particulates out of the optical path. A setscrew holds the filter to the SensAlert IR Sensor housing. Once the hydrophobic filter is removed, the internal waveguide tube should be inspected for cleanliness.

The waveguide and waveguide collar can be removed by inserting rigid instruments such as Allen wrenches into one hole of the waveguide and one hole of the collar. Turning the two instruments in opposite directions will loosen the waveguide allowing the collar to be screwed down on to the waveguide until it can be removed from the SensAlert IR Sensor housing. This will allow the windows of the SensAlert IR Sensor to be cleaned.

Dust can be removed using compressed air. Hard or oily deposits can be removed using Isopropyl alcohol and cotton tipped swabs. Wipe any film or residue or film left by the alcohol on the windows with a clean dry cotton swab. The internal surface of the electro-polished wave-guide tube can be cleaned the same way. Be careful not to leave any particles of the cleaning swab in the waveguide. The waveguide holes can collect pieces of the cleaning swab.

After reassembling the unit (the waveguide and collar should be very tight to both ends of the SensAlert IR Sensor housing after installation. Once the unit is completely reassembled and power is reapplied, the SensAlert IR Sensor must be calibrated. Refer to the calibration section of this manual.

Checking Reaction Time:

Checking a SensAlert IR Sensor reaction time can be done by connecting the detector to the span gas as outlined in section V CALIBRATION. The user must be close to the detector and use no more than 3 feet of hose. Using a stopwatch, measure the time it takes for the detector to reach 45%LEL or 90% of 50%LEL (T90 value). If this value is greater than 30s, an optics cleaning and calibration may be needed. See section V CALIBRATION for this.

Refer to IEC 60079-29-2 for guidance on safe installation, use, and maintenance of this equipment.

Accessories

Part Number	Description
821-2102-01	ADAPTOR KIT, IR SAMPLE DRAW (Used for sample draw applications, not required for performance approval)
821-2104-01	WEATHER GUARD ASSEMBLY, SENSALERT IR SENSOR (Not required for performance approval)
821-2001-01	Remote Sensor Junction Box

VIII. DRAWING SECTION

Figure # Title _____

Error! Reference source not found. Wiring Diagram, SensAlert IR Sensor

Figure 2 SensAlert IR Sensor Separation Kit

Figure 3 Weather Guard Assembly

Figure 4 Weather Guard Exploded View

Figure 5 Sample Draw Configuration

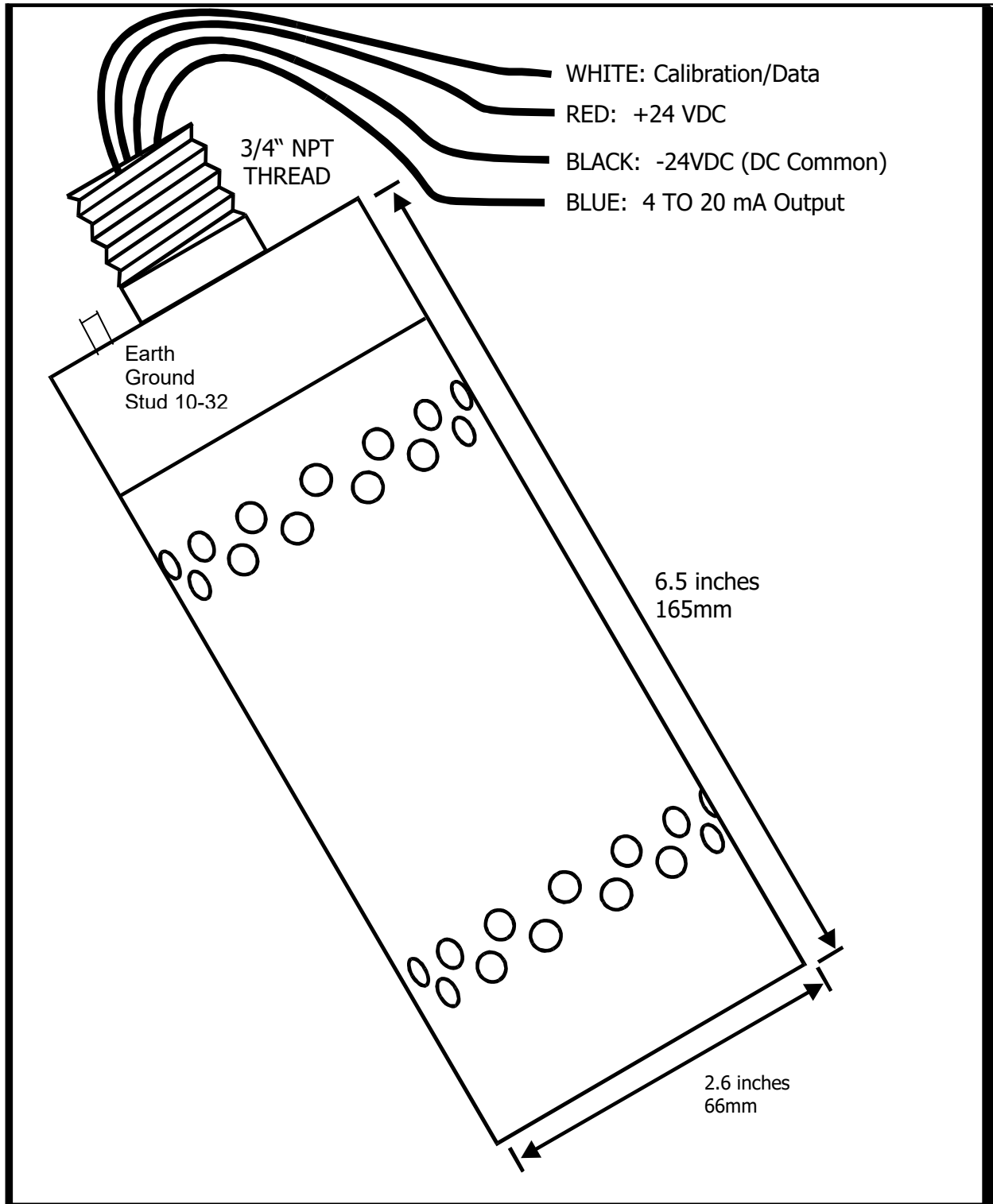
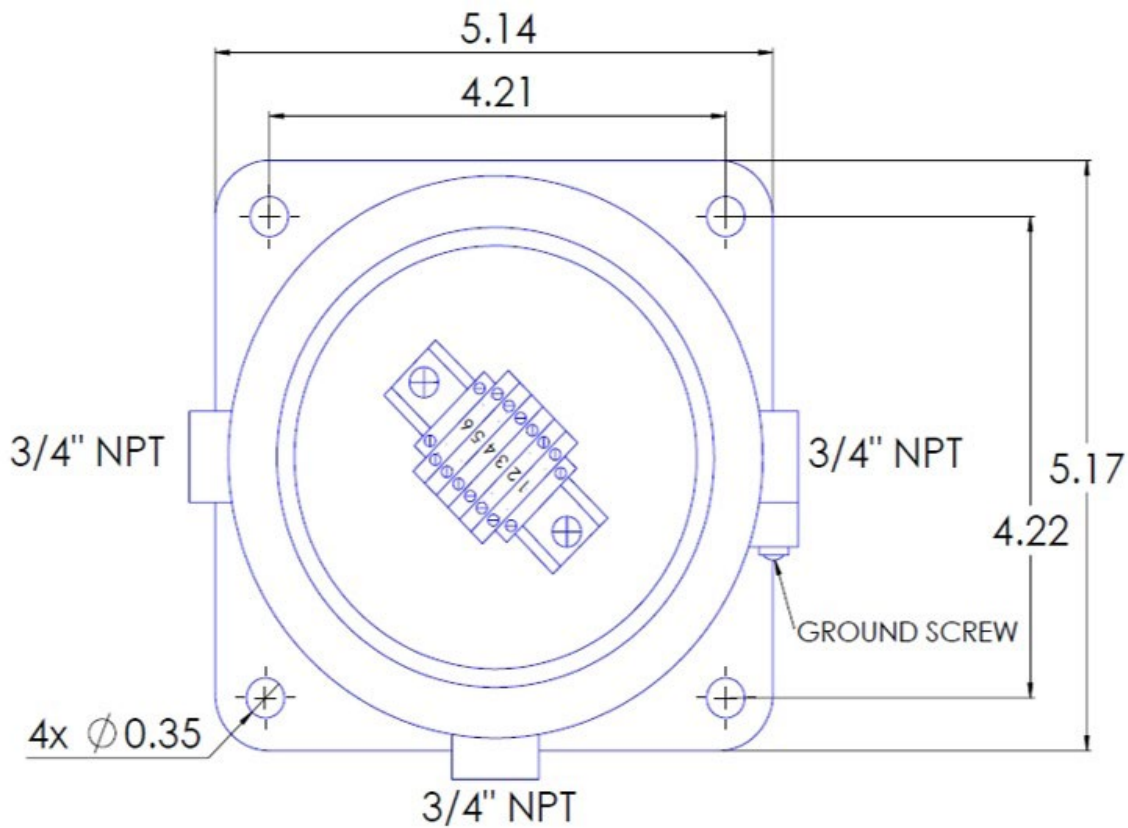

Figure 1 – Wiring Diagram SensAlert IR Sensor

	Black	Red	Blue	White	Yellow	Brown
SensAlert IR Sensor	1	2	3	4	N/A	N/A
	-	+	Analog Out	Comm	Analog Out	Pressure Comp



1. NOTES:
Class I, Div I Group B, C & D
Ex d IICC GB
2. TERMINALS: 6
3. HEIGHT: 4.11" COVER INSTALLED
4. GROUND SCREW ALSO LOCATED UNDER TERMINAL BLOCK

Figure 2 - SensAlert IR Sensor Separation Kit

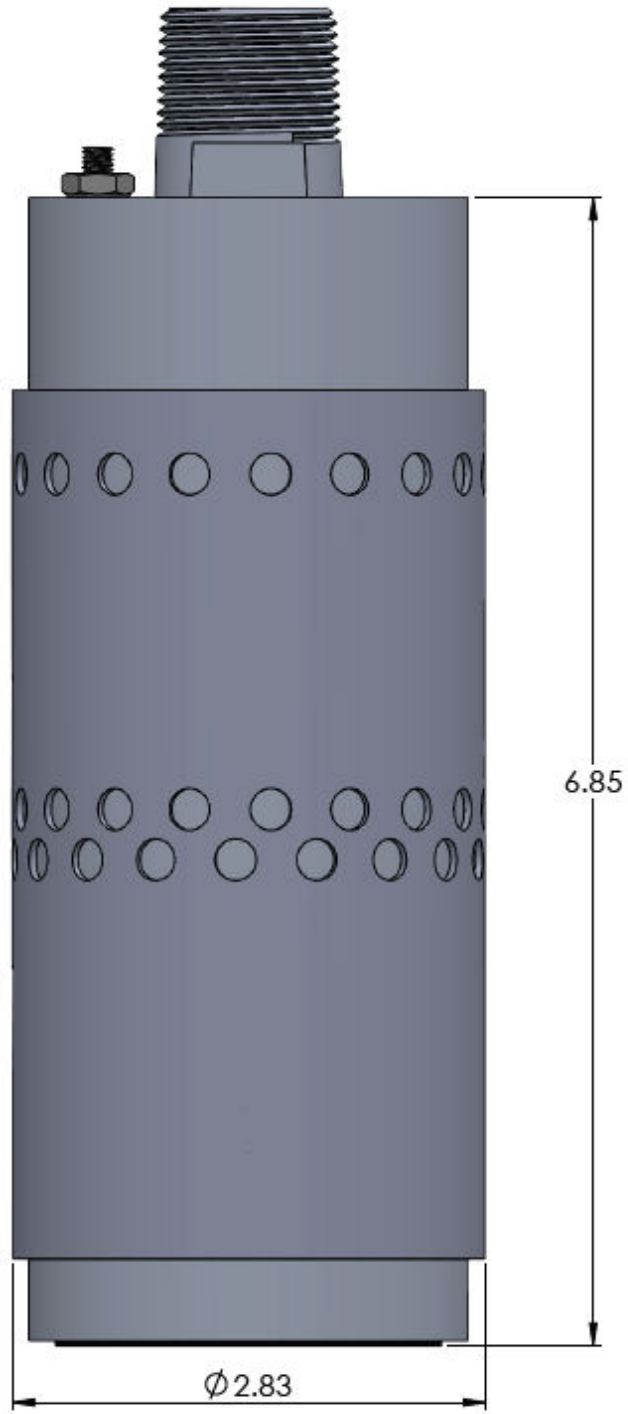

Figure 3 - Weather Guard Assembly

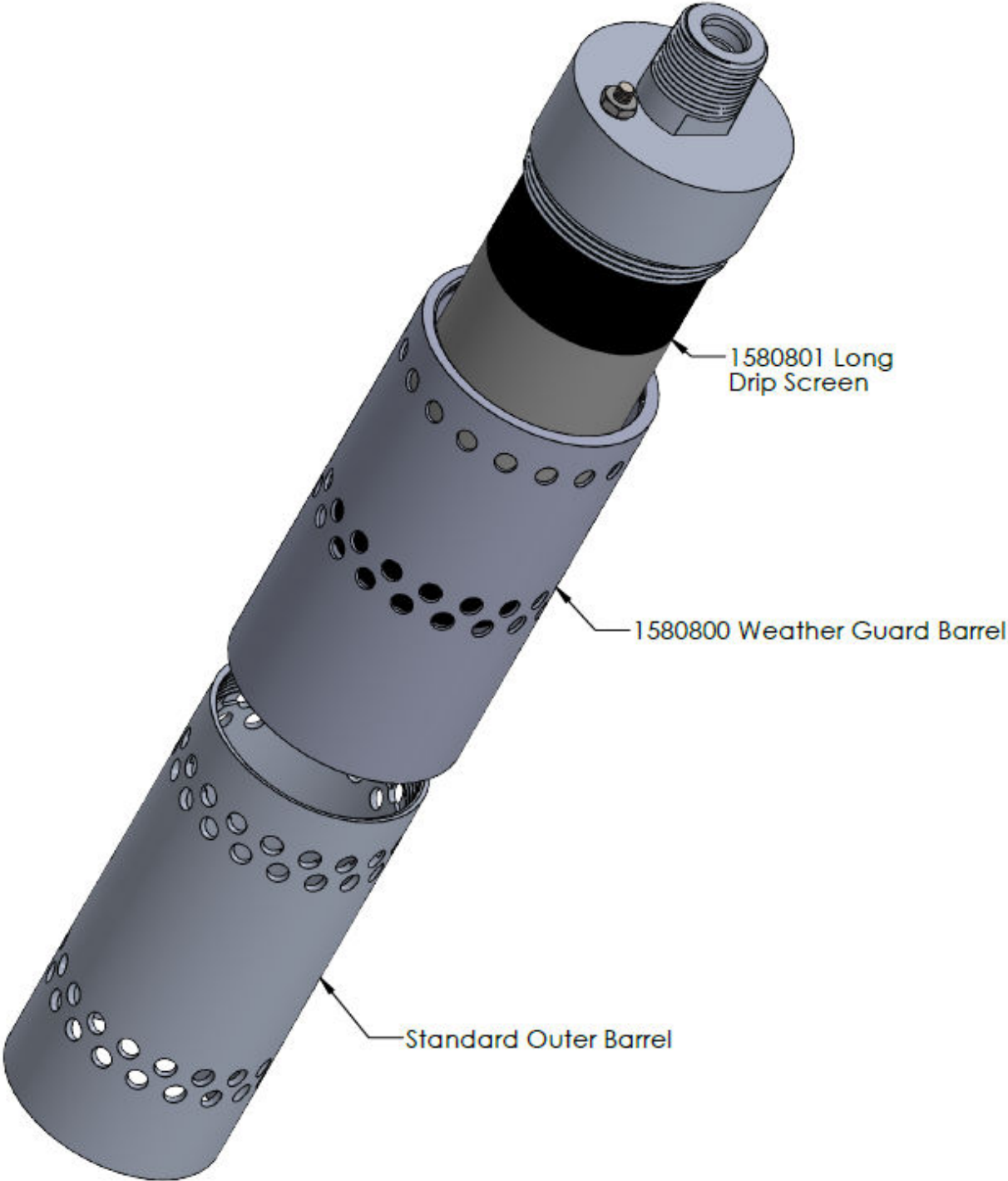

Figure 4 - Weather Guard Assembly Exploded

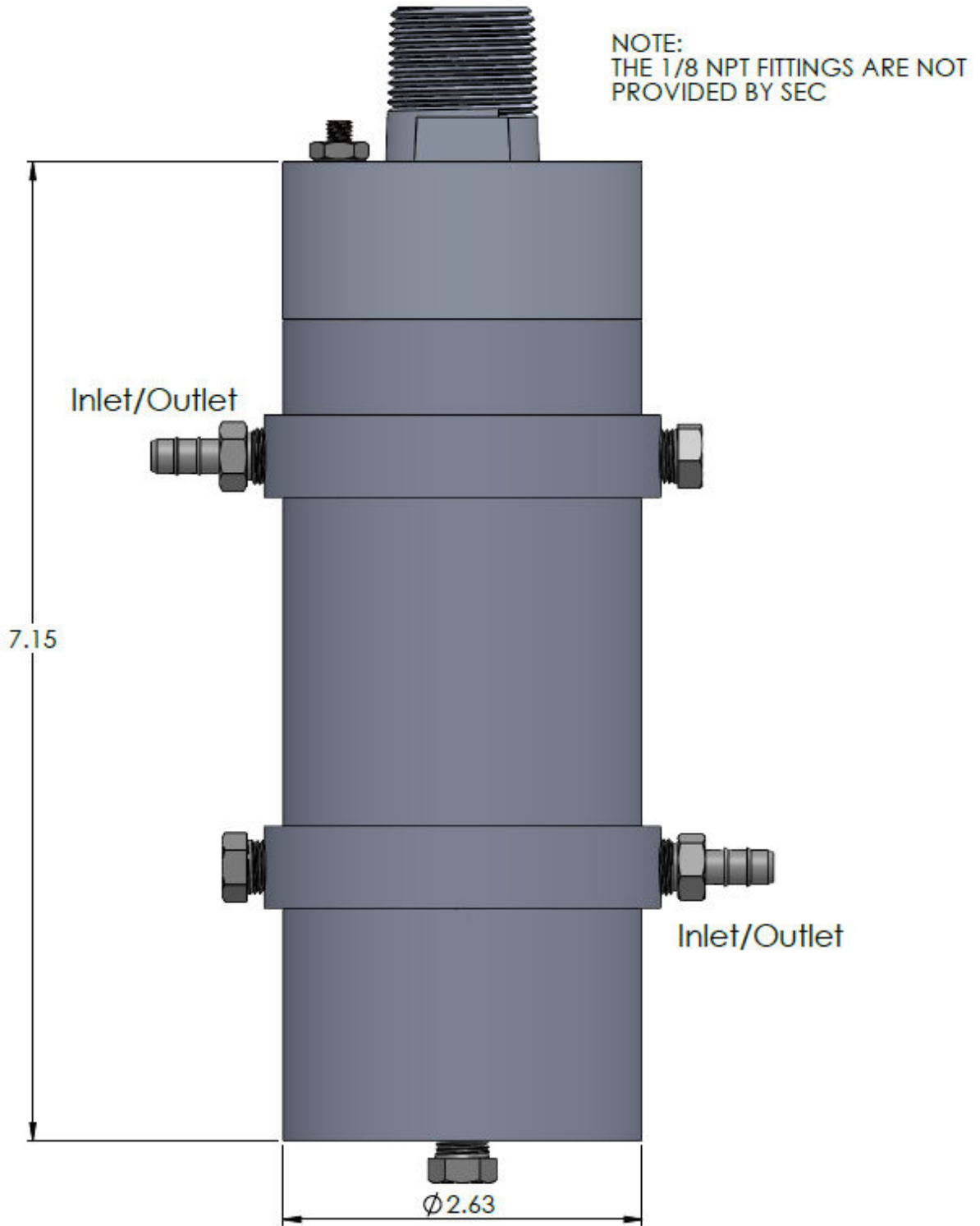

Figure 5 - Sample Draw Configuration

IX. UNIT STATUS FLASH CODES

Flash Rate	Output Current	Reads (Hex)	Status Code (Dec)	Unit Status Label	Description
1	4-20ma	0x00	0	Unit Running	Unit is measuring gas and adjusting 4-20ma output accordingly.
2	2.2ma	0x02	2	Unit Zero Calibrating	Unit goes through its <i>zero calibration</i> procedure.
3	2.0ma	0x03	3	Unit Spanning	Unit goes through its <i>spanning</i> procedure.
4	0-20ma	0x04	4	Unit 4-20ma Calibrating	Unit goes through its <i>4-20ma-calibration</i> procedure. (Factory Only)
5	0.8ma	0x05	5	Unit Warm-up	Unit is warming up.
6	0.0ma	0x06	6	Power-up Fault	Unit has determined a <i>Power-Up</i> fault condition.
7	1.6ma	0x07	7	Calibration Fault	Unit has determined an error during <i>calibration</i> procedure.
8	NA	0x08	8	NA	Currently Not Used
9	0.0ma	0x09	9	Unit Fault	Unit has determined a <i>Unit_Fault</i> condition.
10	1.0ma	0x0a	10	Optics Fault	Unit has determined an <i>Optics_Fault</i> condition.
11	1.2ma	0x0b	11	Zero Drift Fault	Unit has determined a <i>Zero_Drift_Fault</i> condition.
12	0.0ma	0x0c	12	Configuration Fault	Unit has never been <i>Zeroed</i> , <i>Spanned</i> , <i>Source</i> calibrated, or E ² has a Header byte error.
13	1.4ma	0x0d	13	Hot Zero Calibration	Unit goes through its <i>Hot Temperature calibration</i> procedure. (Factory Only)
14	1.4ma	0x0e	14	Cool Zero Calibration	Unit goes through its <i>Cool Temperature calibration</i> procedure. (Factory Only)
15	4mA->20mA	0x0f	15	Self-Test	Unit generates zero to full scale output (4-20mA & Norm Gas Level)
16	0.2ma	0x10	16	Reference Channel Fault	AGC Potentiometer reaches the minimum predetermined value during the unit AGC procedure.

SensAlert IR Sensor

17	0.4ma	0x11	17	Active Channel Fault	Balance Potentiometer reaches the minimum or maximum predetermined value during the unit Calibration procedure.
18	N/A	0x12	18	Power Fault	24VDC < 18 or 24VDC >32V
19	N/A	0x13	19	Comp Zeroing	
20	N/A	0x14	20	Comp Spanning	
21	N/A	0x15	21	Fixed 4mA	
22	N/A	0x16	22	Fixed 20mA	
24	3.6mA	0x18	24	Flow Fault	Sample Draw ONLY: Unit has detected flow is too high or too low

X. UNIT ERROR CODES

Error Code Label's	Error Code Value's	Error Code (Dec)	Error Code Description's	Unit Status
NO_ERROR	0x00	0	Unit is measuring gas and operating properly	Unit Running
ERR_EEPROM_HEADER_BYTE	0x01	1	EEPROM does not have correct header byte stored.	Configuration Fault
ERR_EEPROM_CHKSUM	0x02	2	Checksum byte from EEPROM does not match calculated checksum on latest EEPROM read..	Configuration Fault
ERR_NO_ZERO_YET	0x03	3	Unit has yet to be zero calibrated.	Configuration Fault
ERR_NO_SPAN_YET	0x04	4	Unit has yet to be spanned.	Configuration Fault
ERR_ZERO_VALUES	0x05	5	Zero values are out of specification limits.	Power-up Fault
ERR_420_CALIB1	0x06	6	When searching for >4vdc level during the 4-20ma calibration procedure, it was unsuccessful in the first three attempts.	Power-up Fault
ERR_420_CALIB2	0x07	7	When searching for the exact 4vdc level during the 4-20ma calibration procedure, it was unsuccessful in the first four attempts.	Power-up Fault
ERR_SIGNAL_HIGH	0x08	8	When the signal level is greater than 4.75vdc at the time it is read during the AGC procedure.	Zero Drift Fault
ERR_4VDC_REF_LOW	0x09	9	When the internal reference voltage is too low.	Unit Fault
ERR_4VDC_REF_HIGH	0x0A	10	When the internal reference voltage is too high.	Unit Fault
ERR_BAL_POT_MAX	0x0B	11	When the Balance digital potentiometer reaches the maximum predetermined value during the unit calibration procedure.	Calibration Fault
ERR_BAL_POT_MIN	0x0C	12	When the Balance digital potentiometer reaches the minimum predetermined value during the unit calibration procedure.	Calibration Fault
ERR_AGC_POT_MAX	0x0D	13	When the AGC digital potentiometer reaches the maximum predetermined value during the unit AGC procedure.	Optics Fault

SensAlert IR Sensor

ERR_AGC_POT_MIN	0x0E	14	When the AGC digital potentiometer reaches the minimum predetermined value during the unit AGC procedure.	Ref Channel Fault
ERR_SPAN_POT_MAX	0x0F	15	When the Span digital potentiometer reaches the maximum predetermined value during the unit span procedure.	Calibration Fault
ERR_SPAN_POT_MIN	0x10	16	When the Span digital potentiometer reaches the minimum predetermined value during the unit span procedure.	Calibration Fault
ERR_NO_HOT_ZERO_YET	0x11	17	Unit has yet to be zeroed while Hot.	Configuration Fault
ERR_NO_COOL_ZERO_YET	0x12	18	Unit has yet to be zeroed while Cool.	Configuration Fault
ERR_UNIT_TEMP_HIGH	0x13	19	Unit Temperature is over the specified upper limit.	Unit Fault
ERR_UNIT_TEMP_LOW	0x14	20	Unit Temperature under the specified lower limit.	Unit Fault
ERR_ANALYTICAL_RANGE	0x15	21	Insufficient Analog Range during spanning	Calibration Fault
ERR_NO_TABLE_YET	0x16	22	Unit has yet to down load a table via the PC and Comm_Link.	Configuration Fault
ERR_SPAN_NO_LONGER_VALID	0x17	23	Range has been changed	Cal Fault
ERR_SPAN_POT_OVERFLOW	0x18	24	Not enough Span pot room for temperature comp. (Span Gain too high)	Cal Fault
ERR_24VDC_LOW	0x19	25	24VDC too Low	Unit Fault
ERR_24VDC_HIGH	0x1A	26	24VDC too High	Unit Fault
PRESSURE_FAULT	0x1B	27	No Pressure Sensor Input	Unit Fault
FAULT_EXTERNAL	0x1C	28	LIM (Fault Version) Either input Active...External Fault Condition	Unit Fault
ERR_RD_PRES	0x1D	29	SensAlert IR Sensor. No response from MPL115A2	Unit Fault

LOW_FLOW	0x34	52	Sample Draw System detected the flow was less than 1/2 of target flow rate (cal val)	Flow Fault
HIGH_FLOW	0x35	53	Sample Draw System detected the flow was greater than 2X target flow rate (cal val)	Flow Fault

Warnings

High Level Interfering Gas	0x84	132	SensAlert IR Sensor	Run (Warning)
Slave Not Found	0x85	133	SensAlert IR Sensor	Run (Warning)
EOL Warning	0x8B	139	SensAlert IR Sensor has reached its end of life	Run (Warning)
Over-Range	0x8C	140	SensAlert IR Sensor gas output over predetermined range	Run (Warning)

Revision	Description
A	Initial Release
-	-

SENSIDYNE[®]

Sensidyne, LP

1000 112th Circle N, Suite 100

St. Petersburg, Florida 33716 USA

800-451-9444 • +1 727-530-3602 • +1 727-539-0550 [fax]

web: www.sensidyne.com • e-mail: info@sensidyne.com